

Service Manual Trucks

Group **37**

Electrical Schematic
VN, VHD VERSION2

From Build Date April 2004

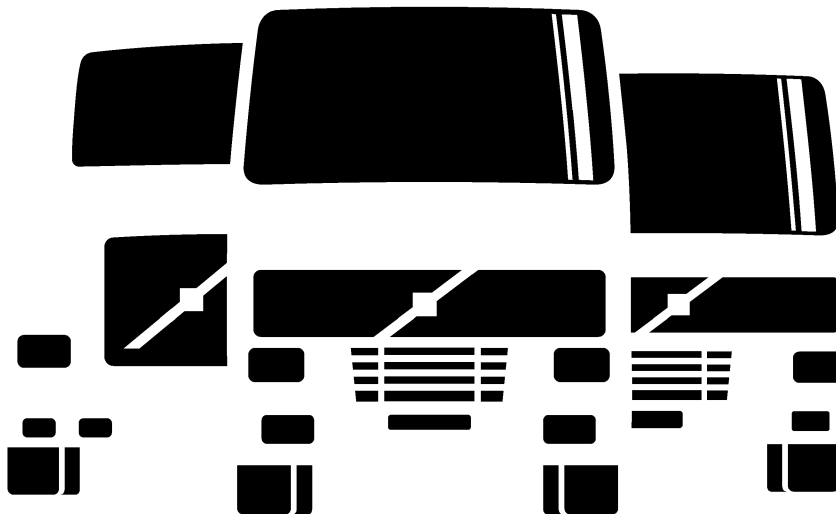

Foreword

The descriptions and service procedures contained in this manual are based on designs and methods studies carried out up to September 2004.

The products are under continuous development. Vehicles and components produced after the above date may therefore have different specifications and repair methods. When this is believed to have a significant bearing on this manual, supplementary service bulletins will be issued to cover the changes.

The new edition of this manual will update the changes.

In service procedures where the title incorporates an operation number, this is a reference to an V.S.T. (Volvo Standard Times).

Service procedures which do not include an operation number in the title are for general information and no reference is made to an V.S.T.

Each section of this manual contains specific safety information and warnings which must be reviewed before performing any procedure. If a printed copy of a procedure is made, be sure to also make a printed copy of the safety information and warnings that relate to that procedure. The following levels of observations, cautions and warnings are used in this Service Documentation:

Note: Indicates a situation, handling or circumstance which should be observed.

Caution: Indicates a potentially hazardous situation which, if not avoided, may result in minor or moderate injury or damage to property.

Warning: Indicates a potentially hazardous situation which, if not avoided, could result in death, serious injury or major damage to property.

Danger: Indicates an imminently hazardous situation which, if not avoided, will result in death or serious injury.

Volvo Trucks North America, Inc.
Greensboro, NC USA

Order number: PV776-20007110

© 2004 Volvo Trucks North America, Inc., Greensboro, NC USA

All rights reserved. No part of this publication may be reproduced, stored in retrieval system, or transmitted in any forms by any means, electronic, mechanical, photocopying, recording or otherwise, without the prior written permission of Volvo Trucks North America, Inc..

USA15171

Contents

VN, VHD	3
Electrical Schematics	3
Illustrations	77
Illustration Index, Wiring Harnesses	77
Reference	149
Reference List: Fuses	149
Reference List: Relays	155
Reference List: Components	156
Reference List: Inline Connectors	176
Reference List: Physical Splice Connectors	186
Glossary	190
Wire Color Codes	191

VN, VHD

Electrical Schematics

For instructions on using the schematics, see service information on “Wiring Diagram User Guide” in Group 37.

Also see:

“Reference List: Fuses” page 149

“Reference List: Components” page 156

“Reference List: Inline Connectors” page 176

“Glossary” page 190

“Wire Color Codes” page 191

Schematic Index

AA	Power supply, starting and charging system (1 of 2)	Fig. 1: AA page 6
AB	Power supply, starting and charging system (2 of 2)	Fig. 2: AB page 7
AC	Grounding (1 of 2)	Fig. 3: AC page 8
AD	Grounding (2 of 2)	Fig. 4: AD page 9
BA	Vehicle ECU (1 of 2)	Fig. 5: BA page 10
BB	Vehicle ECU (2 of 2)	Fig. 6: BB page 11
BC	Instrument cluster, Connectors A and B	Fig. 7: BC page 12
BD	Instrument cluster, Connector C	Fig. 8: BD page 13
BE	Instrumentation, Qualcomm	Fig. 9: BE page 14
BF	Instrumentation, Volvo Link	Fig. 10: BF page 15
BG	Bodybuilder Options, VHD	Fig. 11: BG page 16
BH	Road Relay	Fig. 12: BH page 17
BI	Bodybuilder Module	Fig. 13: BI page 18
BJ	Touch Lock	Fig. 14: BJ page 19
BK	Secondary Instrument Cluster	Fig. 15: BK page 20
CA	Engine Control Common	Fig. 16: CA page 21
CB	Engine Interface, D12	Fig. 17: CB page 22
CC	Engine Control, ISX and ICON	Fig. 18: CC page 23
CE	Fuel filter heater	Fig. 19: CE page 24
CF	Engine brake switches	Fig. 20: CF page 25
CH	Inside/outside air cleaner, VHD	Fig. 21: CH page 26
CI	Engine Control, Cummins ISX without ICON	Fig. 22: CI page 27
CO	Engine Electronics, D12D	Fig. 23: CO page 28
DB	Transmission ECU, Autoshift II	Fig. 24: DB page 29
DC	Transmission ECU, Lightning	Fig. 25: DC page 30

DD	Transmission ECU, Meritor G	Fig. 26: DD page 31
DE	Transmission ECU, Allison, VHD (1 of 2)	Fig. 27: DE page 32
DF	Transmission ECU, Allison, VHD (2 of 2)	Fig. 28: DF page 33
DG	Transmission ECU, Freedomline	Fig. 29: DG page 34
DP	PTO	Fig. 30: DP page 35
EA	ABS ECU	Fig. 31: EA page 36
EB	Suspension ECU 6x2	Fig. 32: EB page 37
FA	Air Dryer / Heated Drain Valve	Fig. 33: FA page 38
FB	Lift Axle, VHD	Fig. 34: FB page 39
FC	Chassis Air Solenoids, VHD	Fig. 35: FC page 40
FD	Chassis Air Solenoids, VN	Fig. 36: FD page 41
FE	Central Tire Inflation system	Fig. 37: FE page 42
GA	LCM Lighting Control Module (1 of 2)	Fig. 38: GA page 43
GB	LCM Lighting Control Module (2 of 2)	Fig. 39: GB page 44
GC	Marker Lights	Fig. 40: GC page 45
GD	Driving / Signal Lights	Fig. 41: GD page 46
GE	Driving / Fog Lights	Fig. 42: GE page 47
GF	Tail Lights and Alarm	Fig. 43: GF page 48
GG	Back of Cab Lights, Daycabs	Fig. 44: GG page 49
GH	Back of Cab Lights, Sleeper cabs	Fig. 45: GH page 50
GI	Snowplow and Beacon Lights	Fig. 46: GI page 51
GP	Windshield Wiper/Washer	Fig. 47: GP page 52
GQ	Horn	Fig. 48: GQ page 53
HA	Climate Control Unit	Fig. 49: HA page 54
HB	Climate Control Unit, Bunk	Fig. 50: HB page 55
HC	Shore Power/Inverter	Fig. 51: HC page 56
HD	Bunk Functions/Refrigerator (VN 430, 630, 670)	Fig. 52: HD page 57
HE	Bunk Functions/Refrigerator/Sink (VN 780)	Fig. 53: HE page 58
HF	L3 Sleeper Functions without LECM	Fig. 54: HF page 59
HG	Sleeper Climate Control without LECM L3	Fig. 55: HG page 60
IA	Interior Courtesy Lights	Fig. 56: IA page 61
IB	Power Seats	Fig. 57: IB page 62
IC	Power Windows/Electric Mirrors	Fig. 58: IC page 63
ID	Power Windows/Mirrors without DCP	Fig. 59: ID page 64
IE	Door Functions/Internal Lights	Fig. 60: IE page 65

IF	Cigar Lighter/Auxiliary Power (Cab Front)	Fig. 61: IF page 66
IG	Smoke Detector	Fig. 62: IG page 67
JA	SRS Airbag	Fig. 63: JA page 68
JB	VORAD	Fig. 64: JB page 69
JC	Steering Wheel Module/Marker Interrupt Switches	Fig. 65: JC page 70
KA	Audio System, 4-speaker	Fig. 66: KA page 71
KB	Audio System, 6-speaker	Fig. 67: KB page 72
KC	Audio System, 6-speaker with subwoofer, TV Prep	Fig. 68: KC page 73
MA	Trailer Cable	Fig. 69: MA page 74
NA	Auxiliary switches	Fig. 70: NA page 75
XA	Diagnostics	Fig. 71: XA page 76

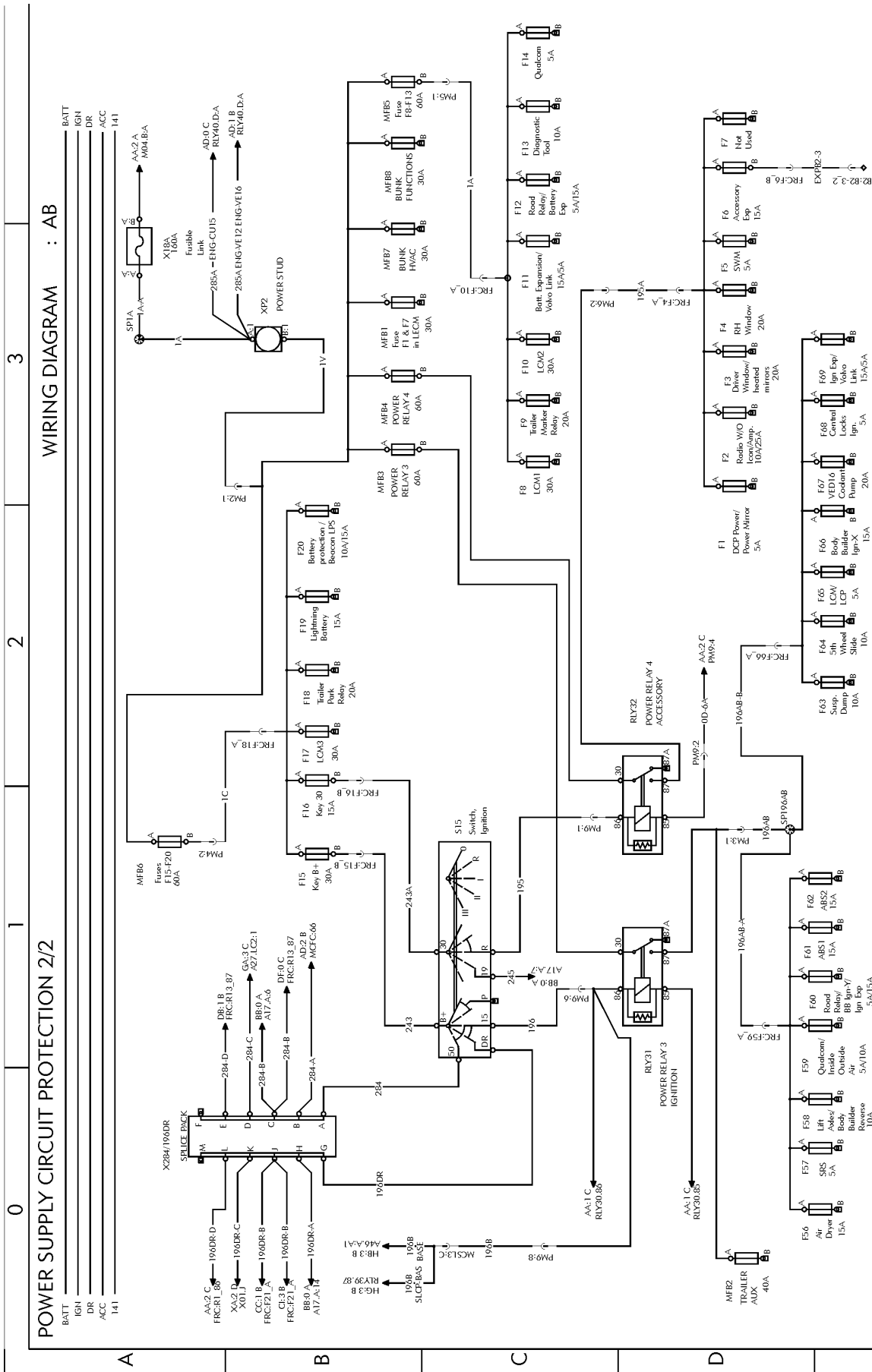

Fig. 2: AB

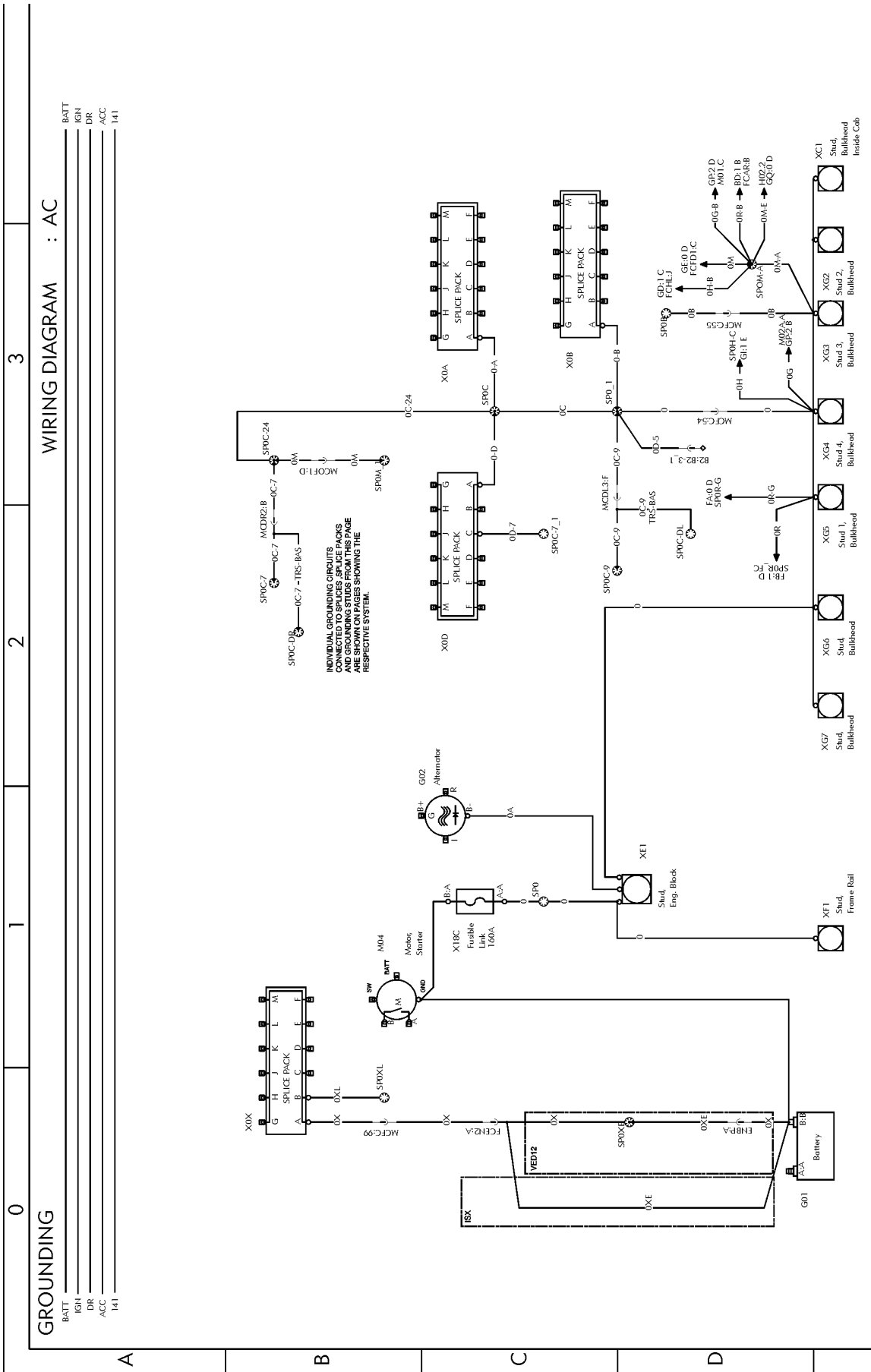

Fig. 3: AC

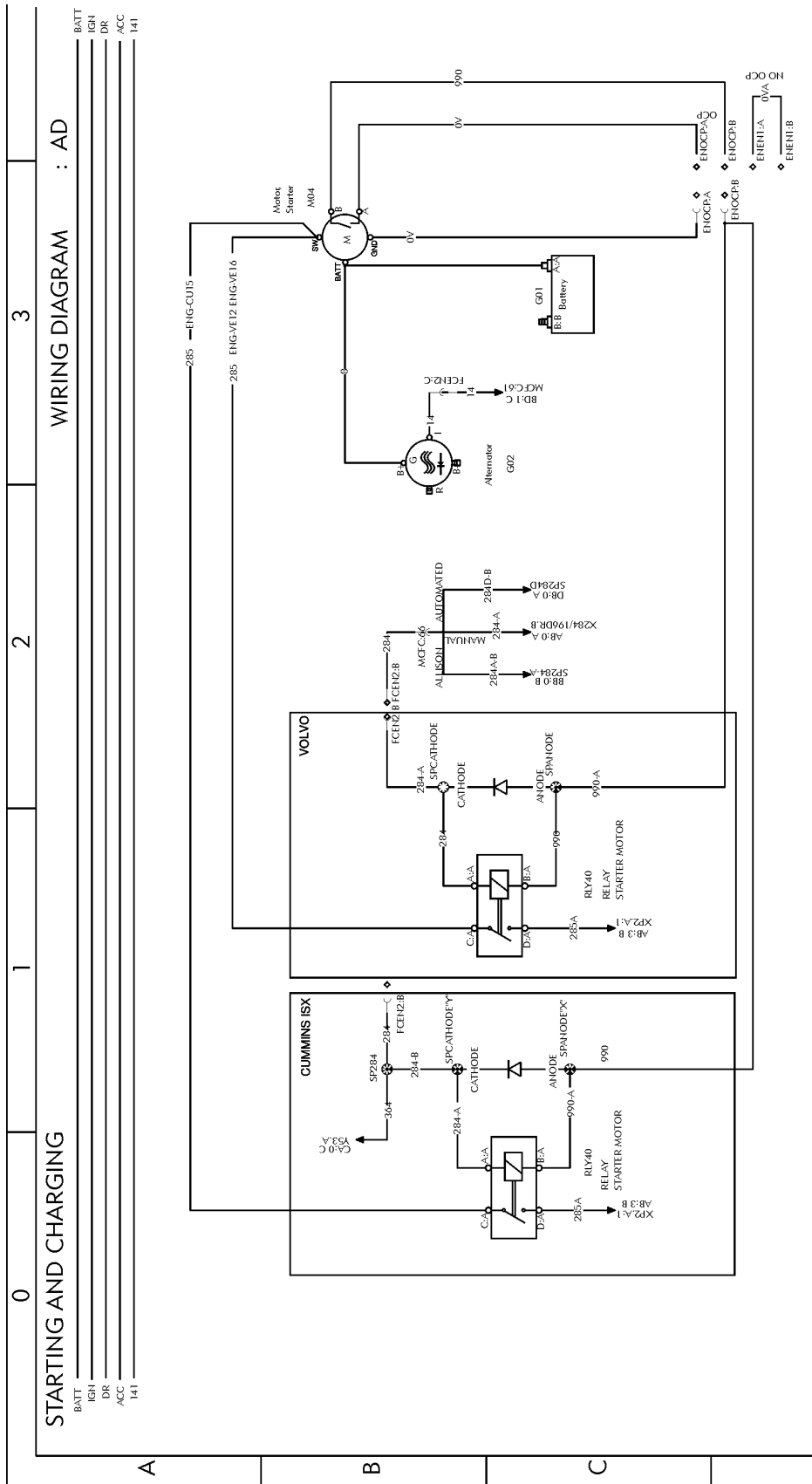

Fig. 4: AD

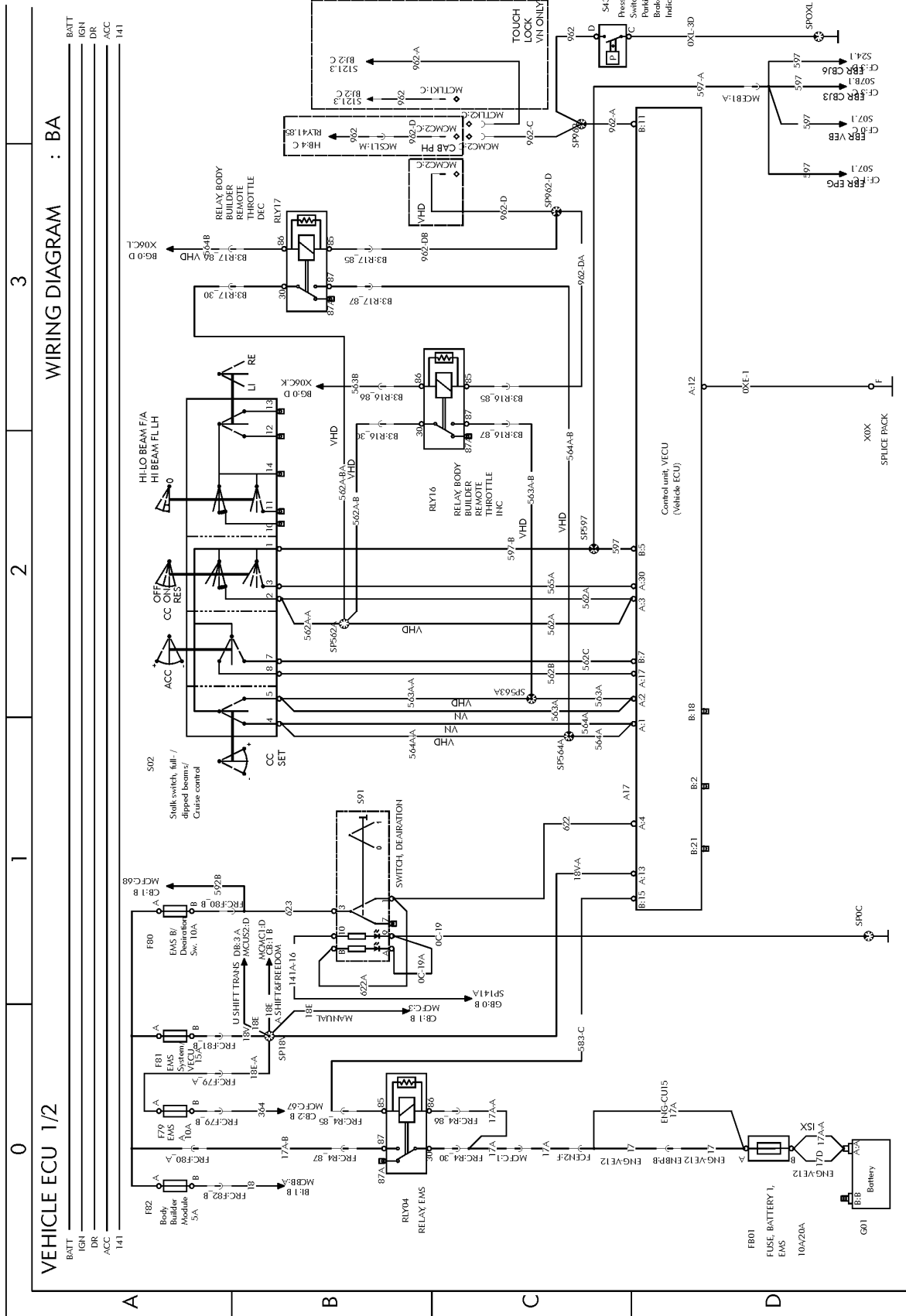

Fig. 5: BA

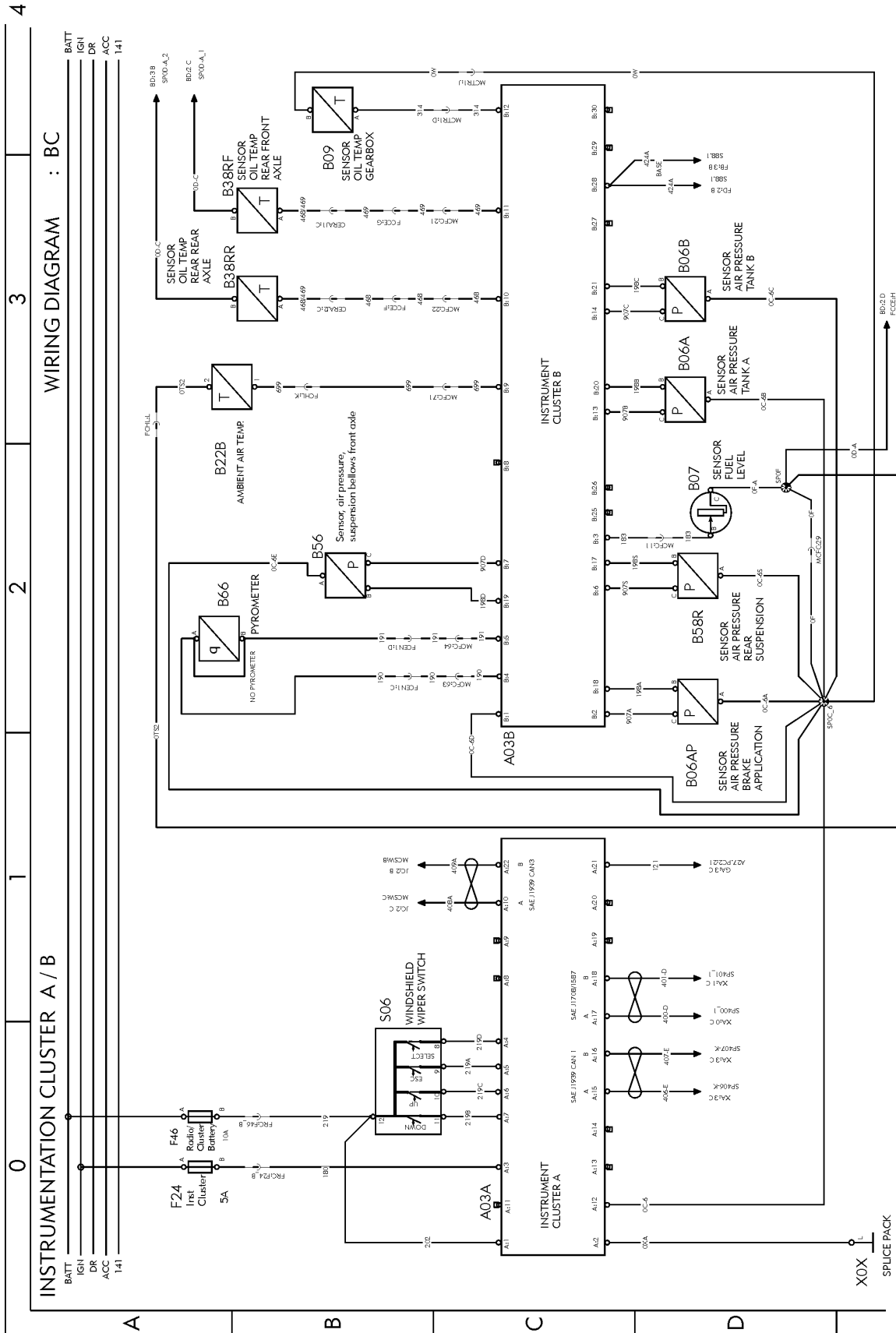

Fig. 7: BC

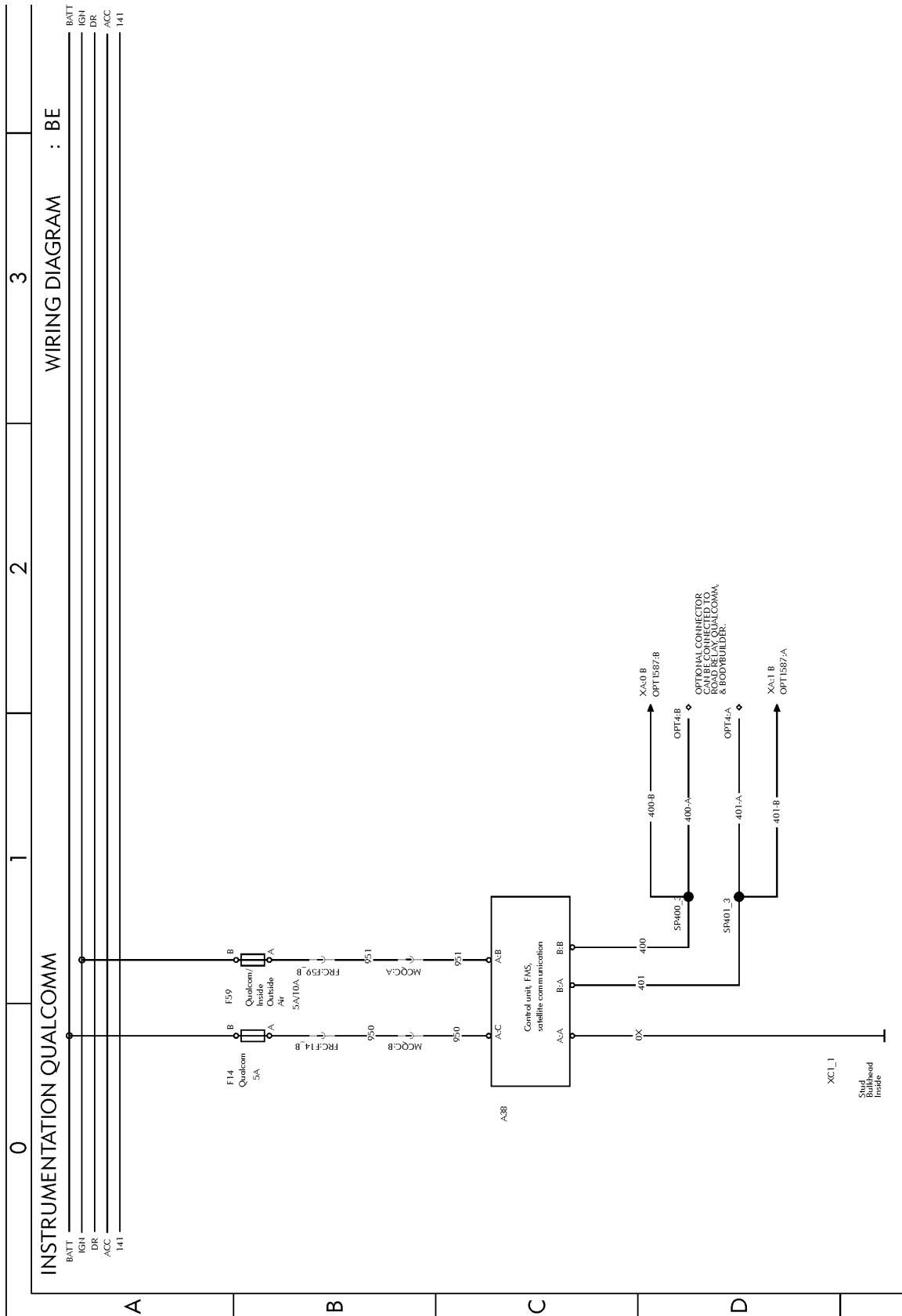

Fig. 9: BE

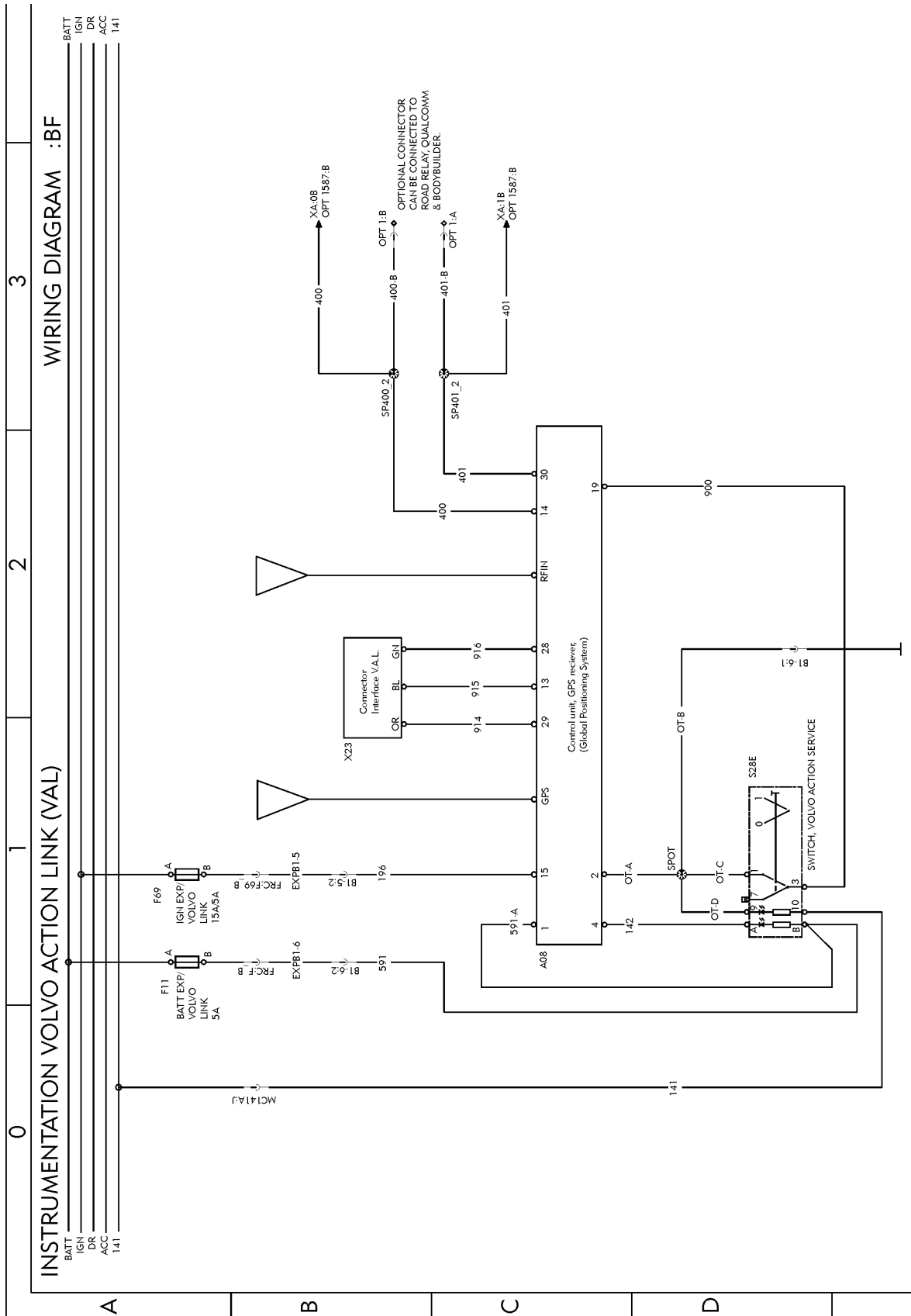

Fig. 10: BF

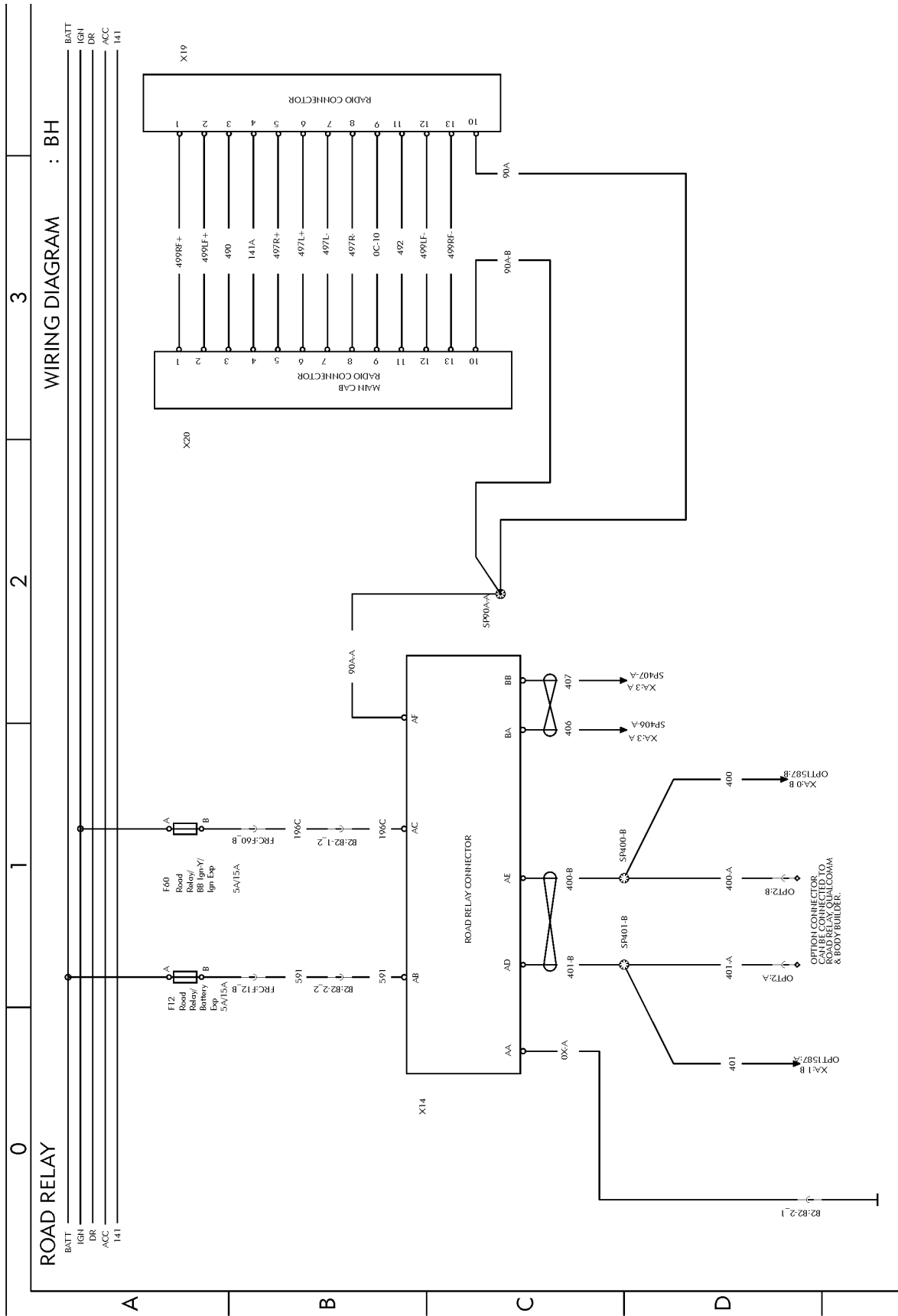

Fig. 12: BH

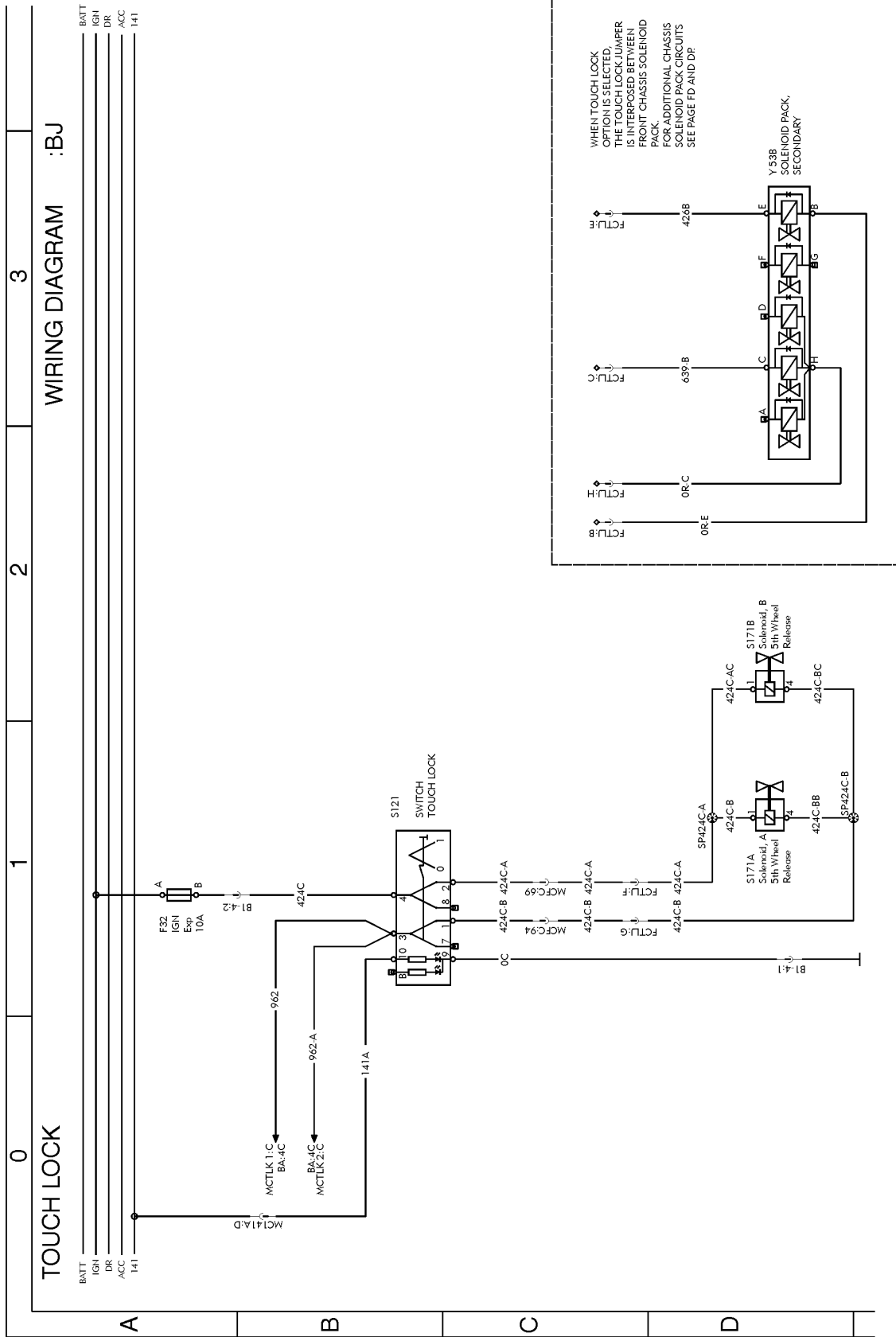

Fig. 14: BJ

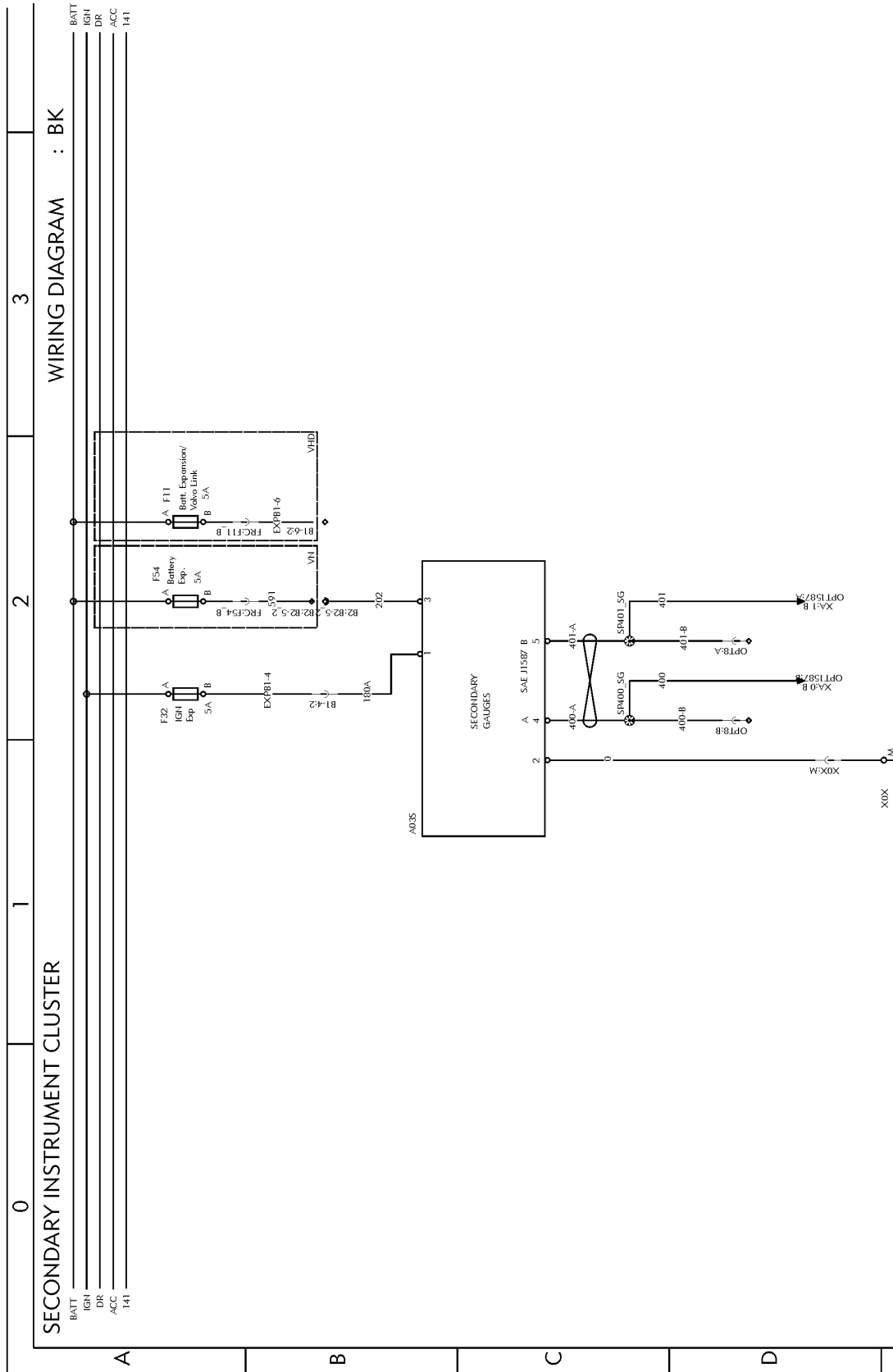

Fig. 15: BK

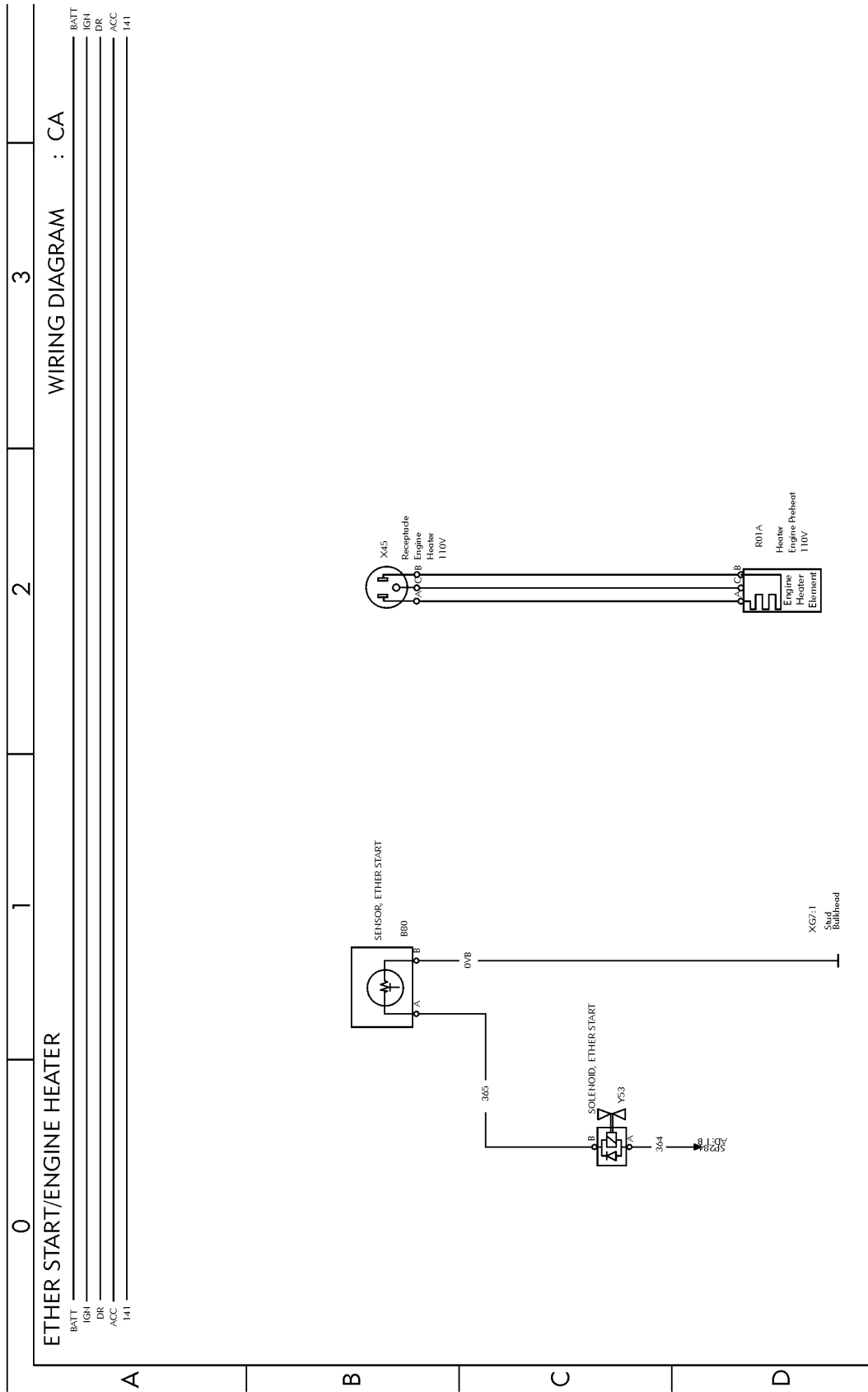

Fig. 16: CA

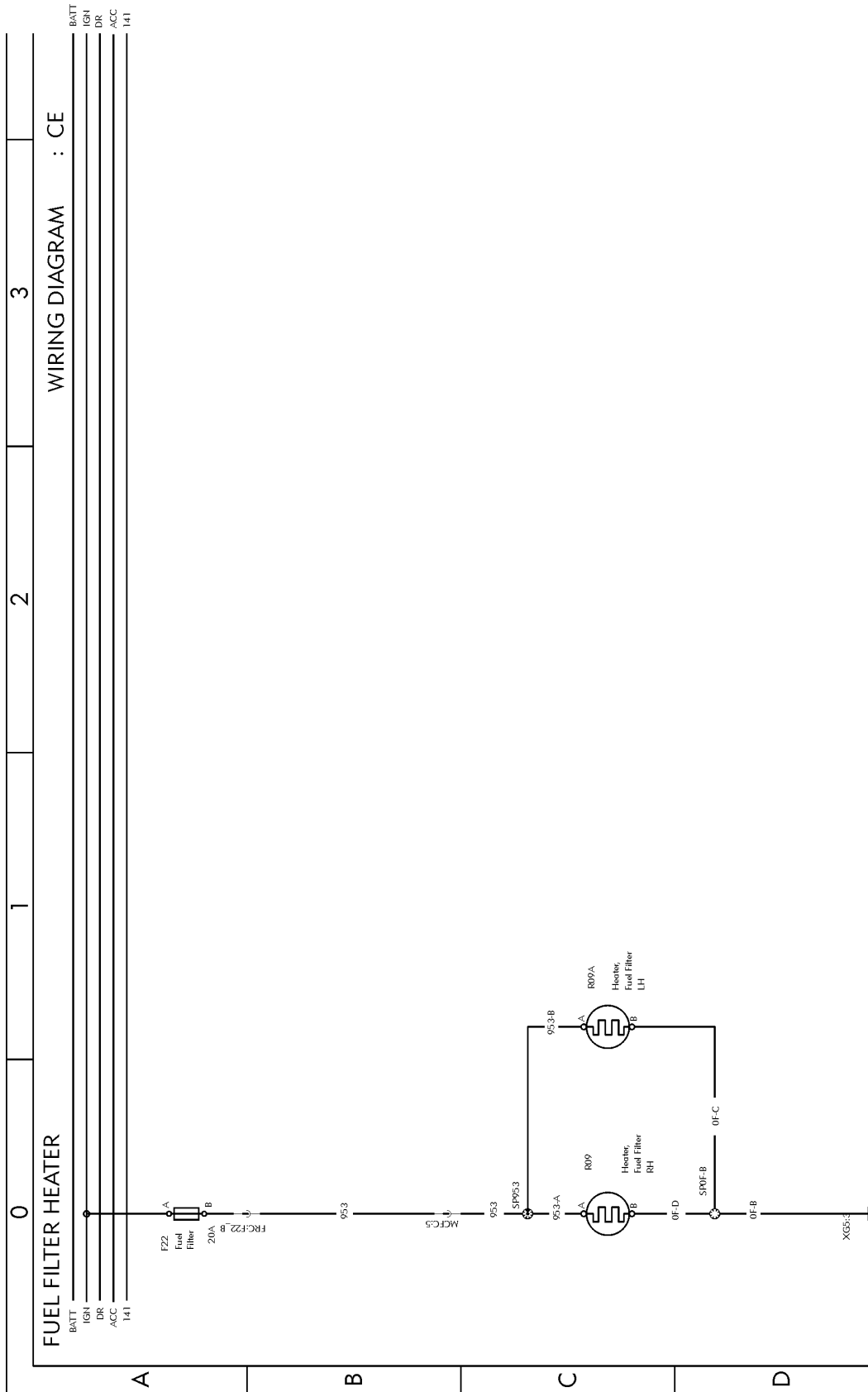

Fig. 19: CE

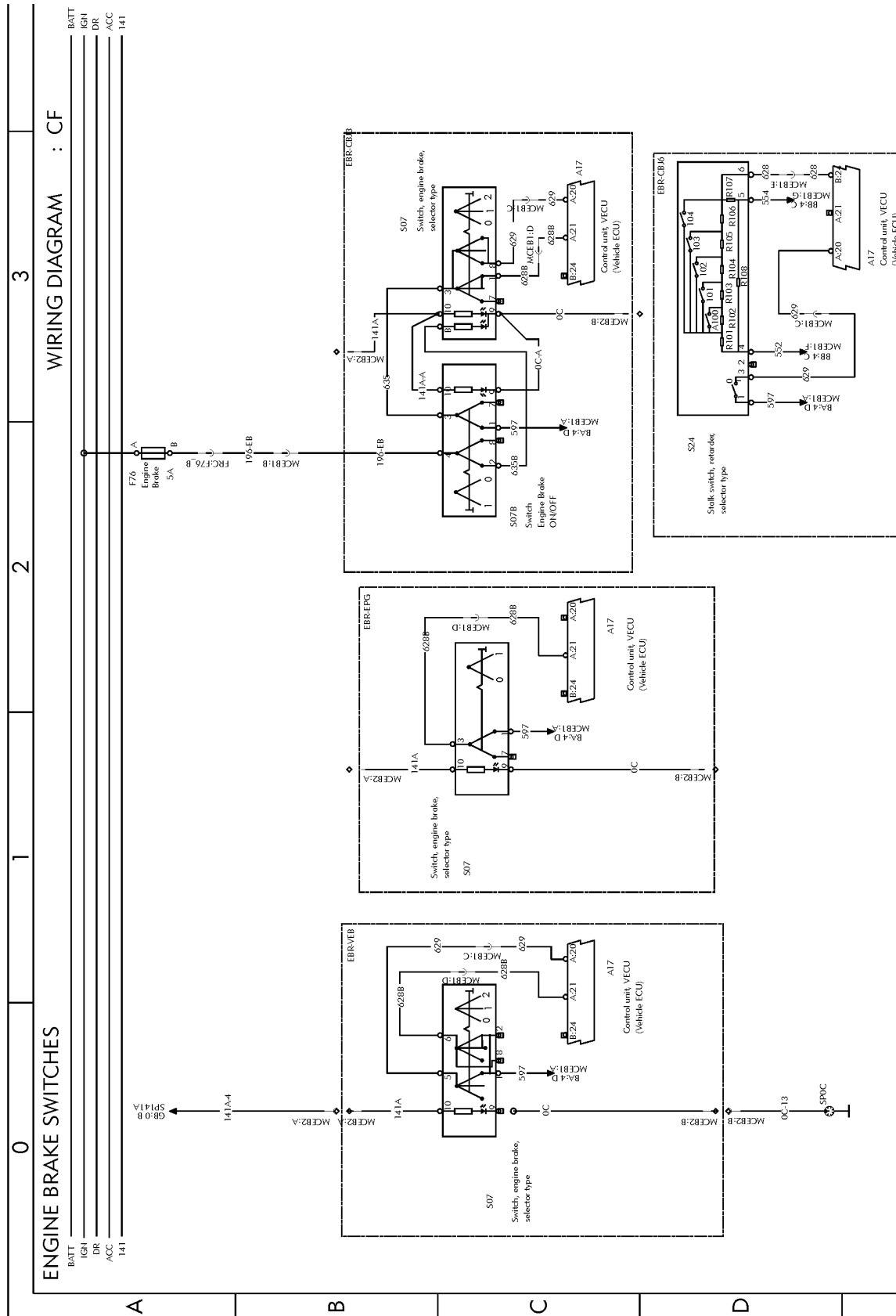

Fig. 20: CF

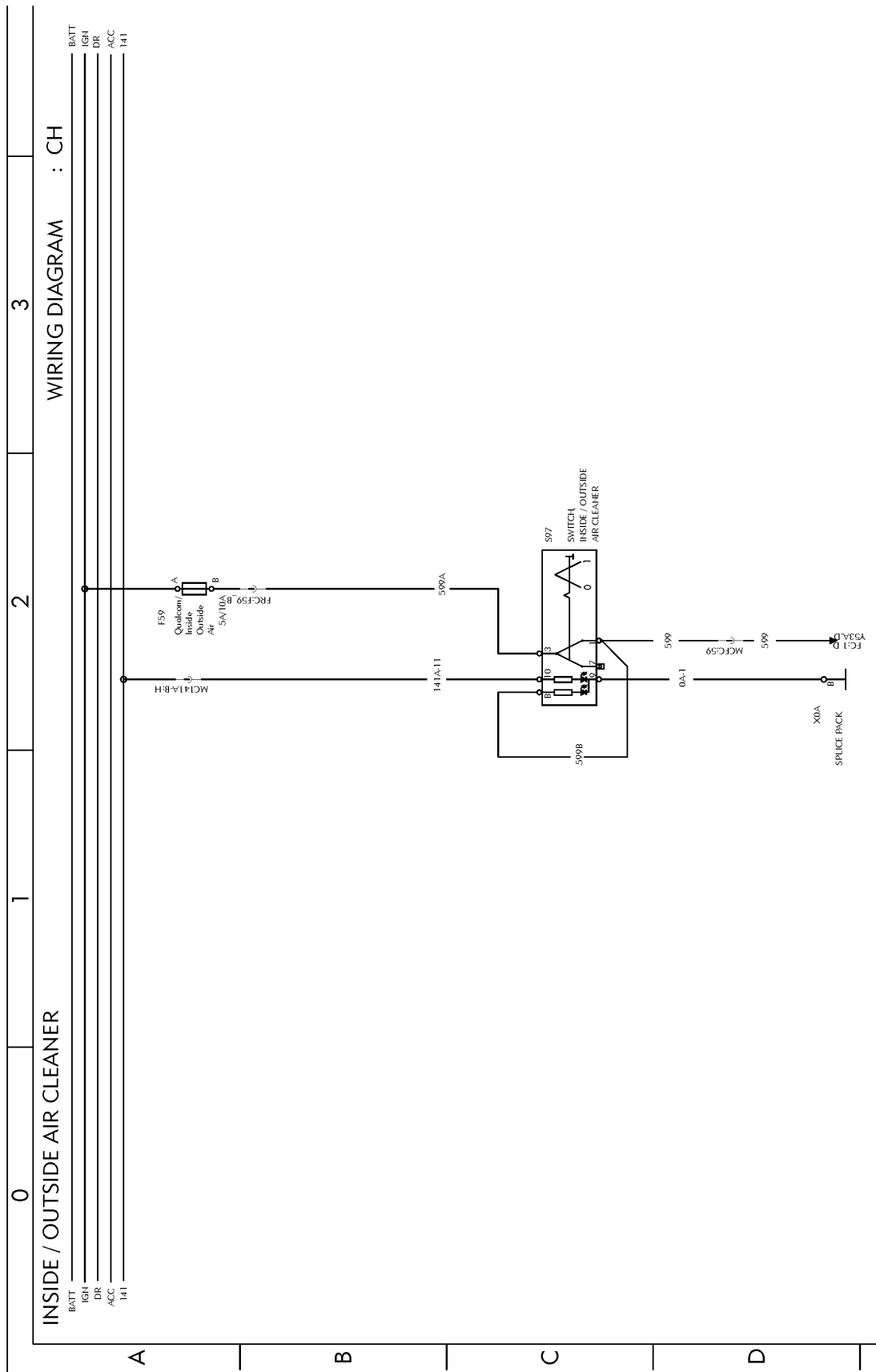

Fig. 21: CH

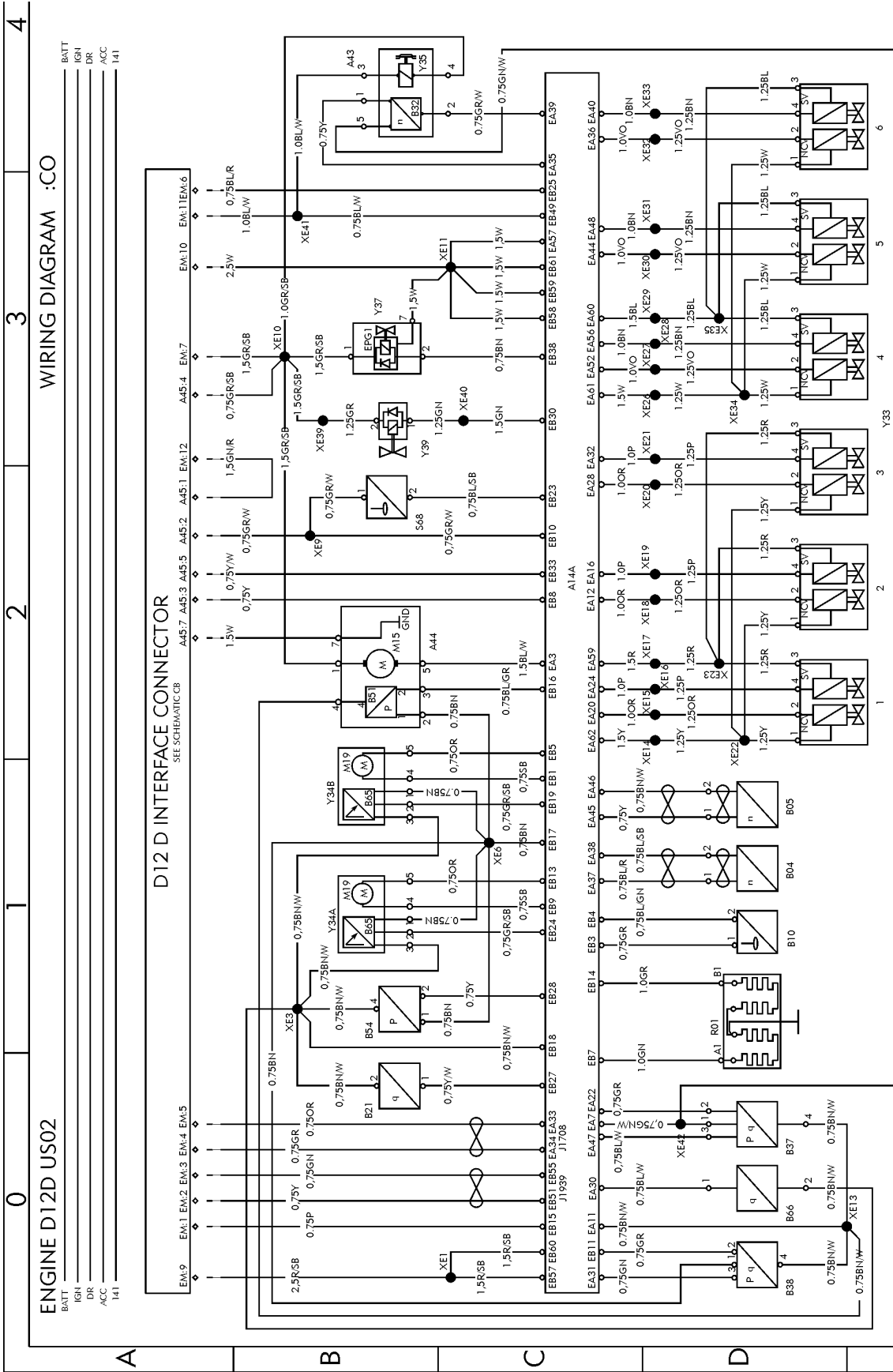

Fig. 23: CO

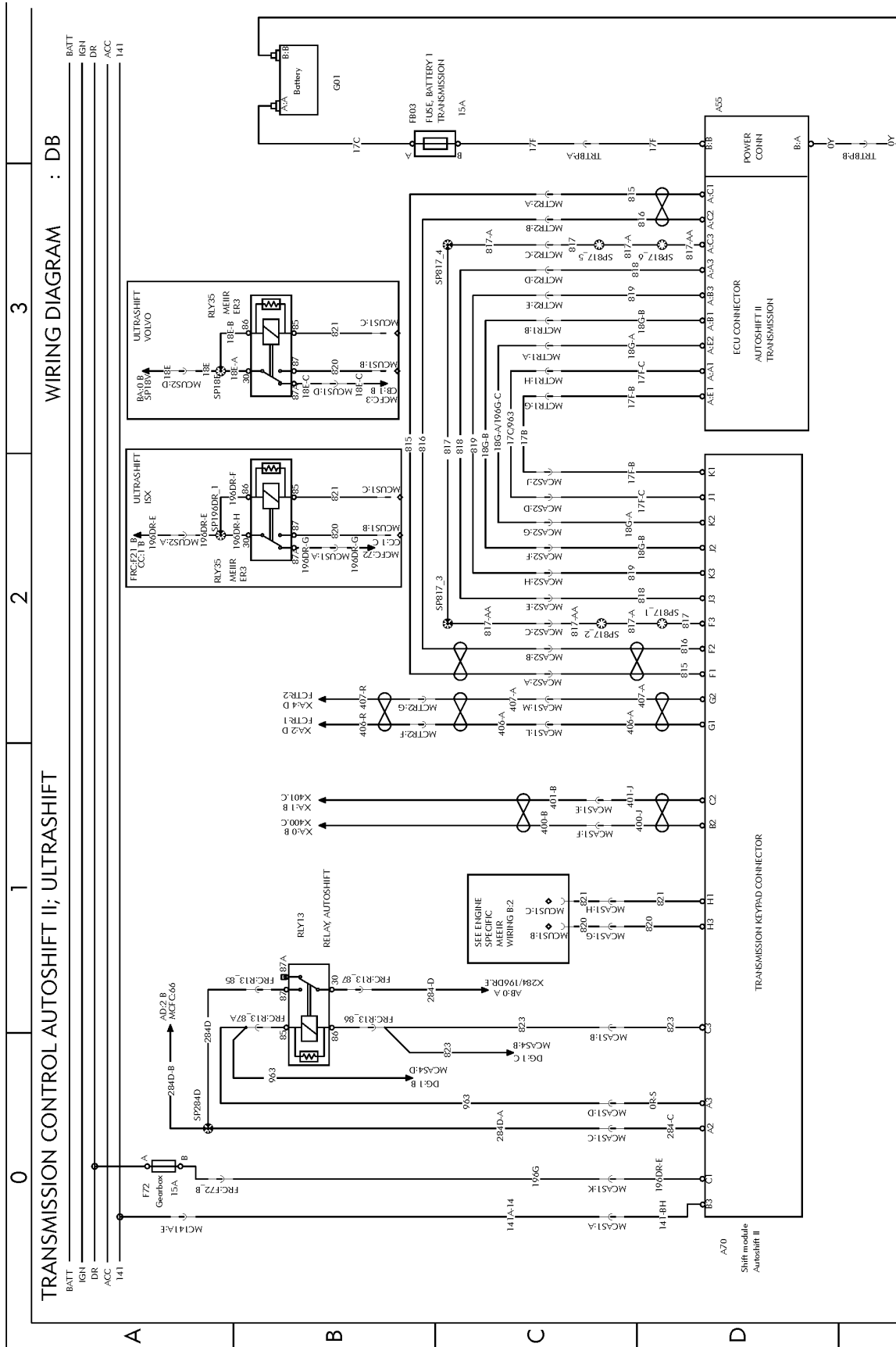

Fig. 24: DB

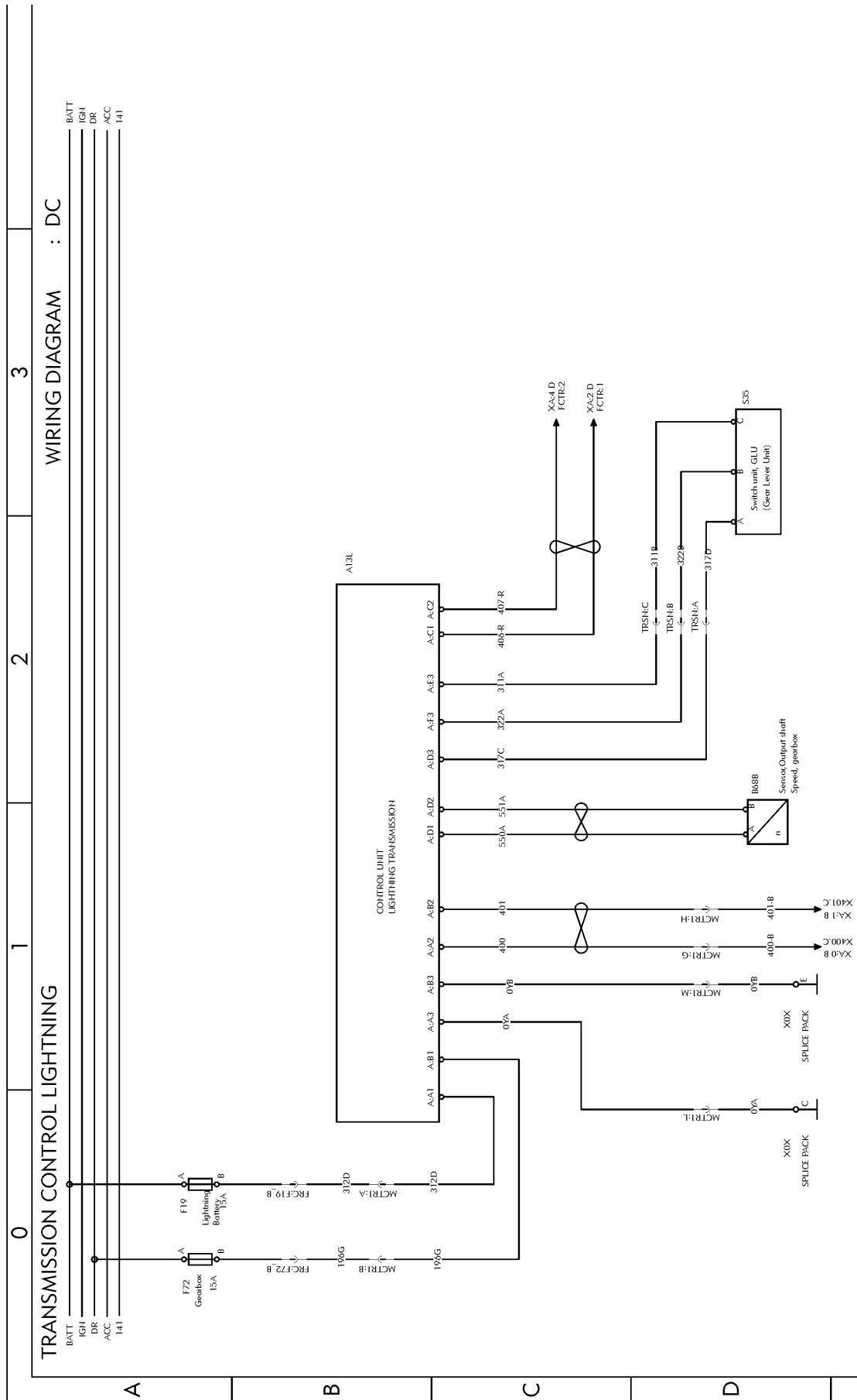

Fig. 25: DC

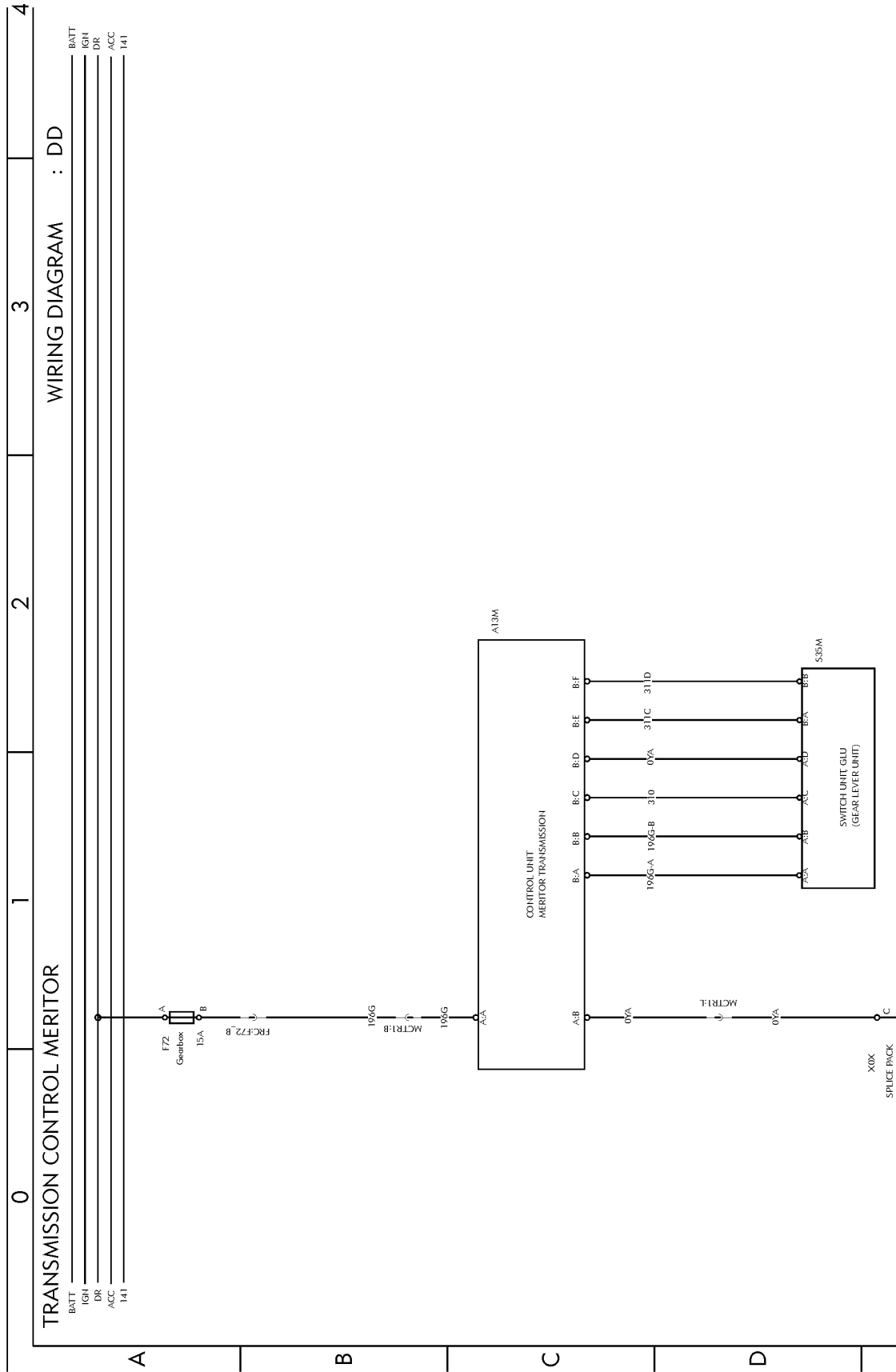

Fig. 26: DD

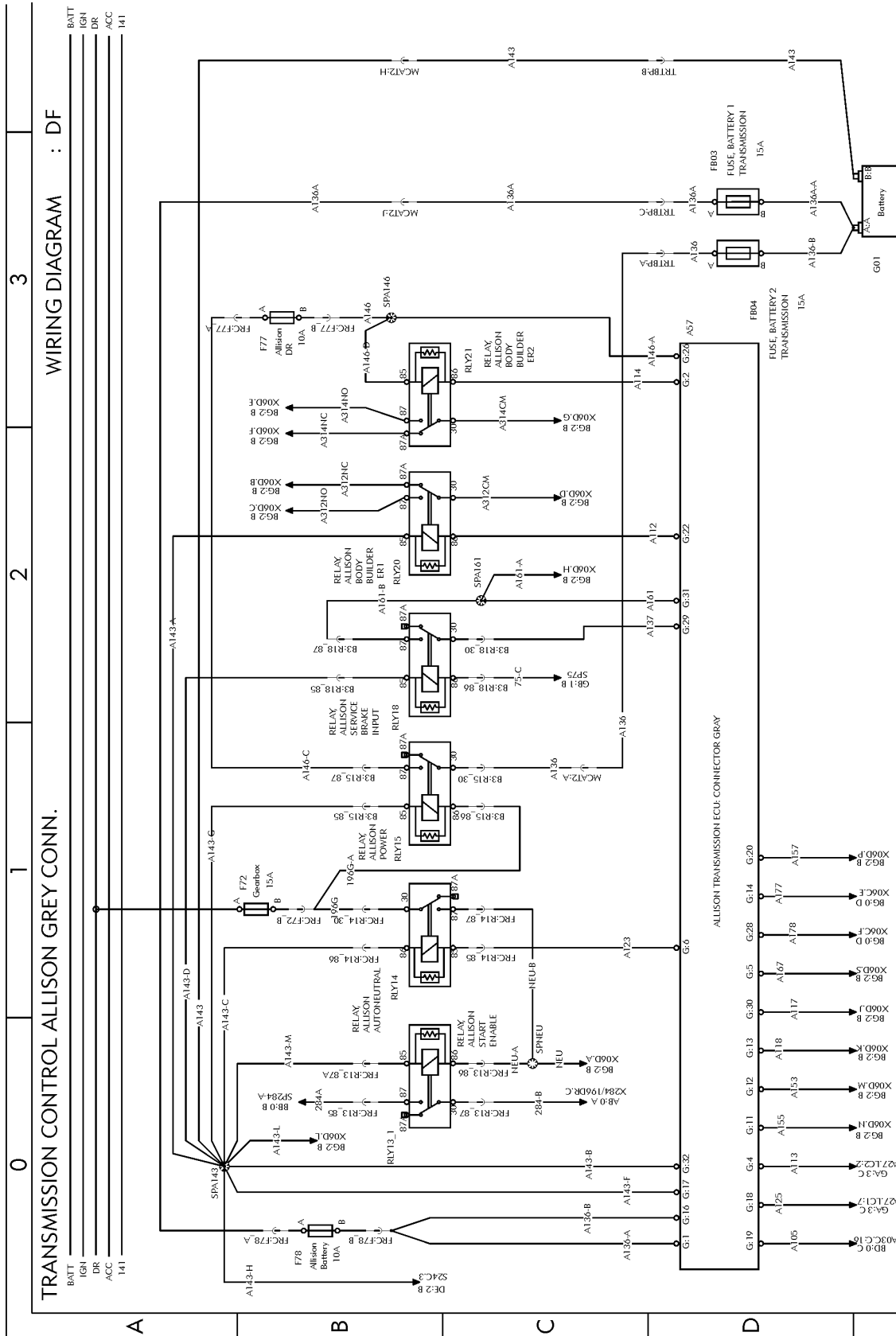

Fig. 28: DF

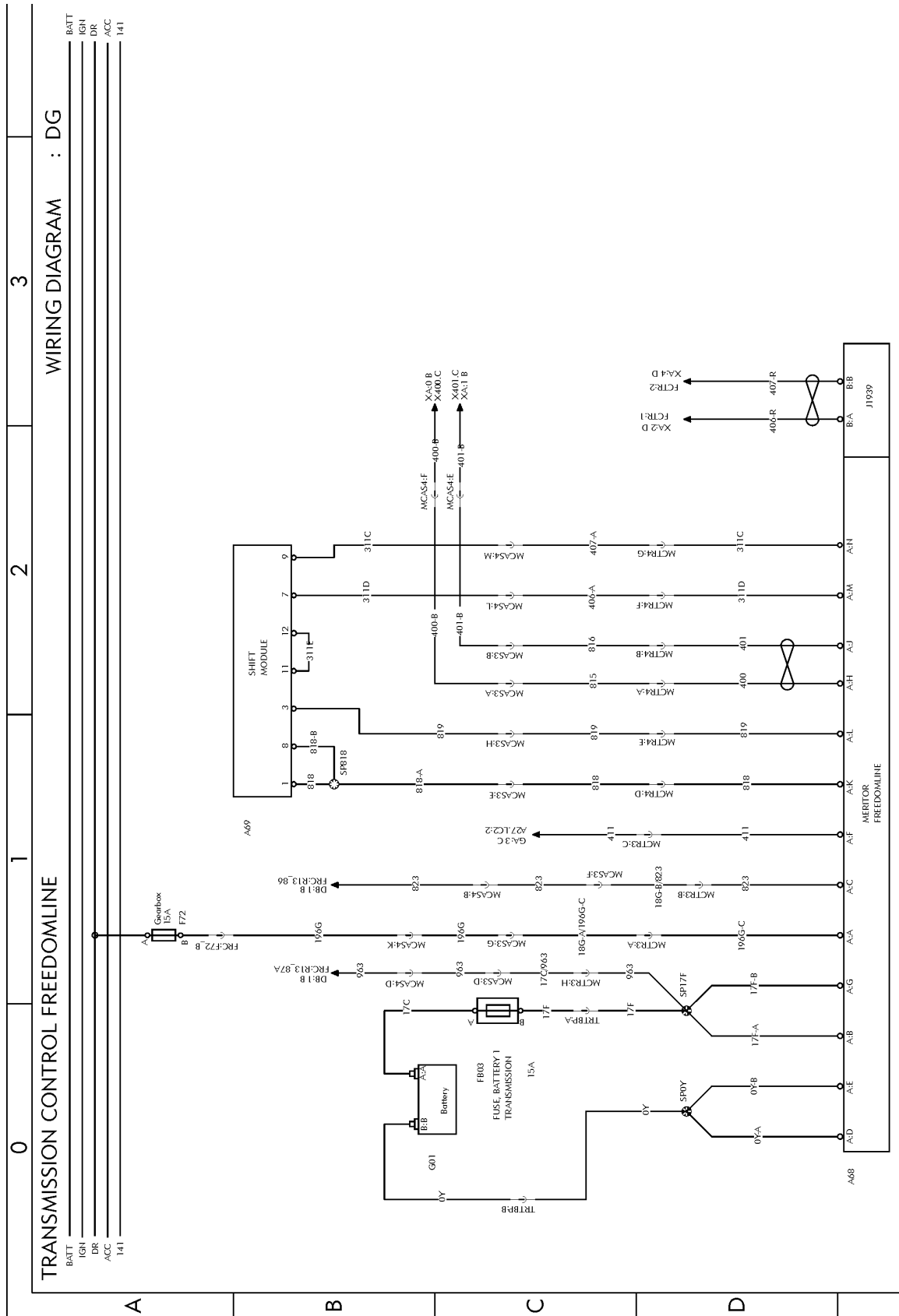

Fig. 29: DG

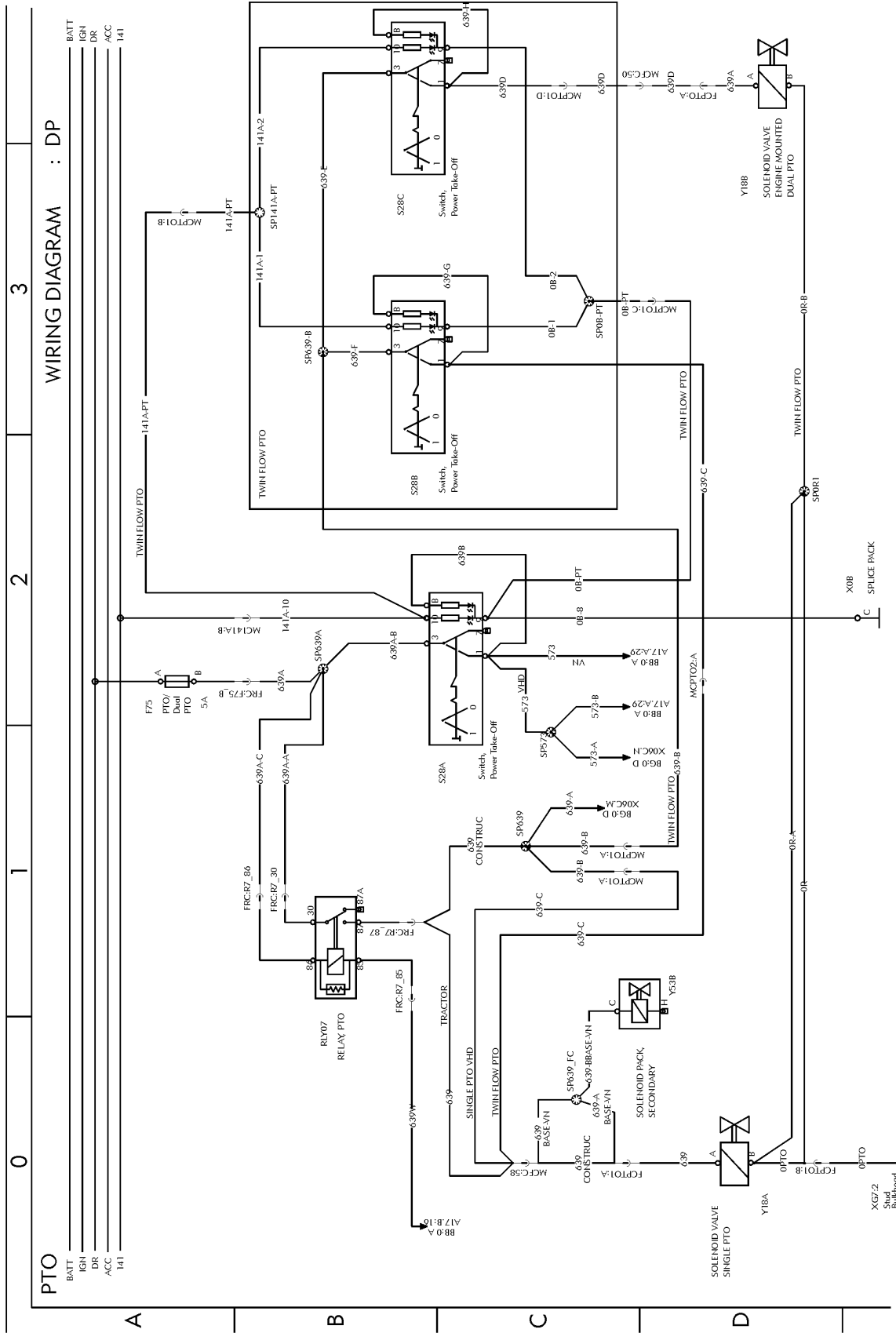

Fig. 30: DP

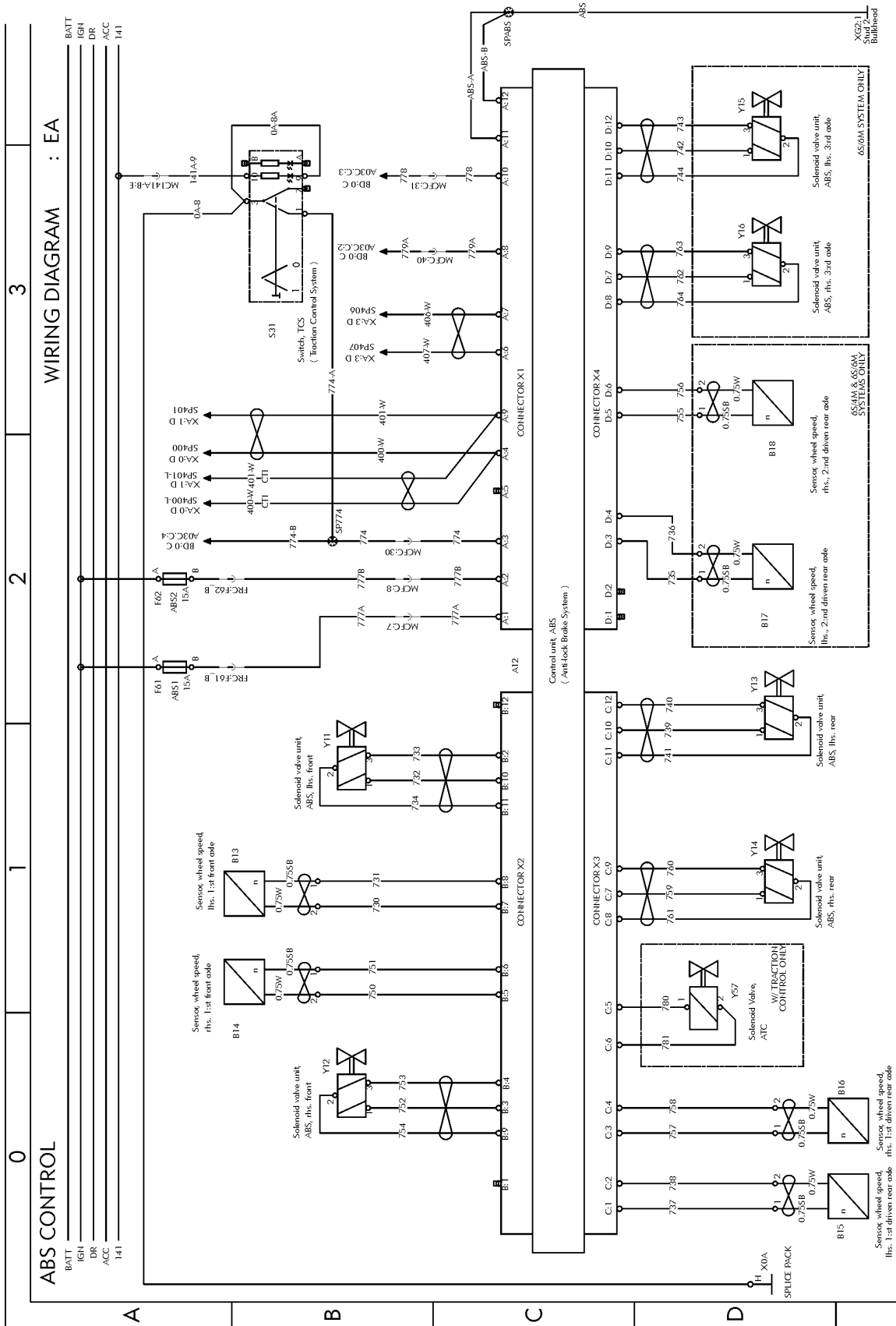

Fig. 31: EA

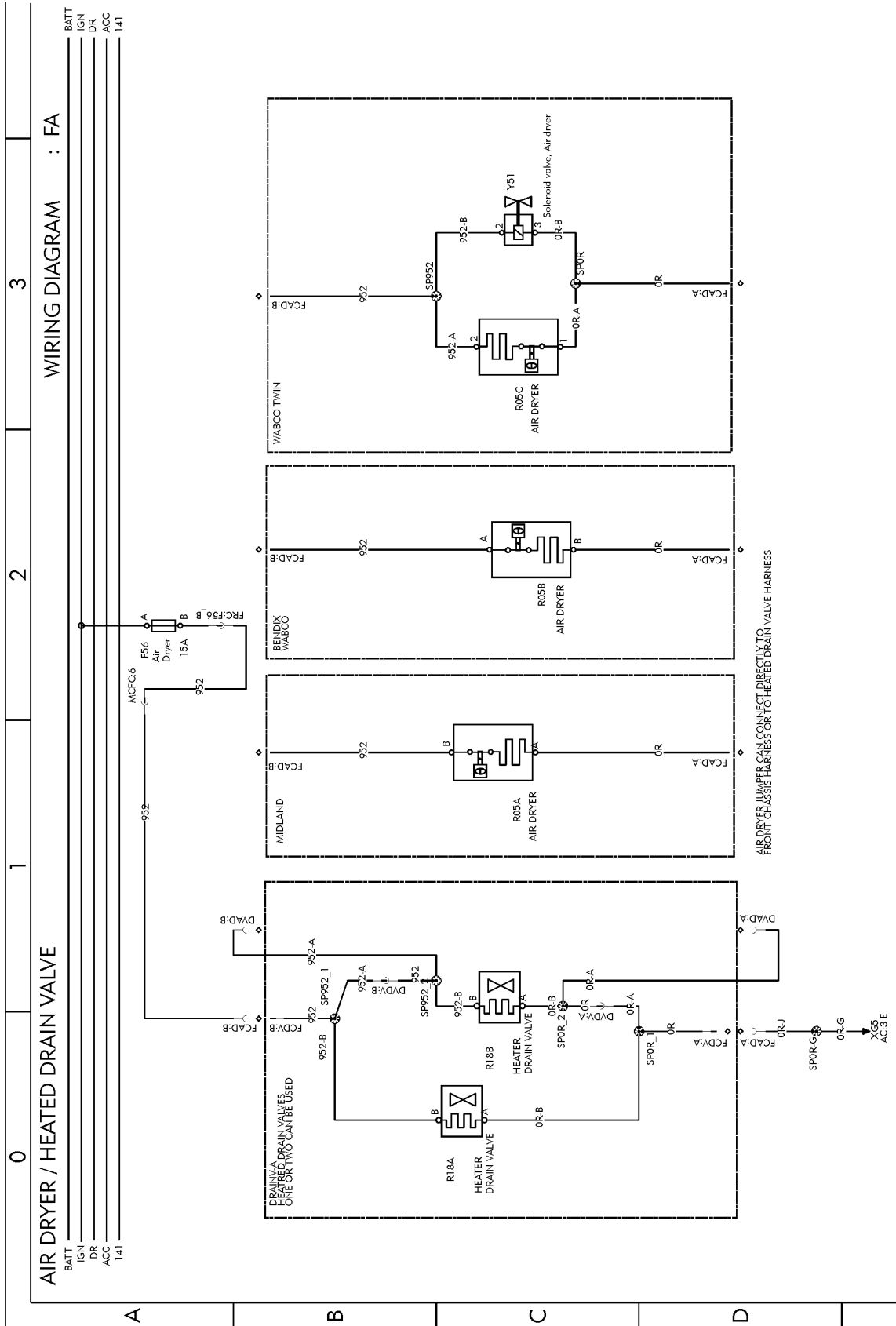

Fig. 33: FA

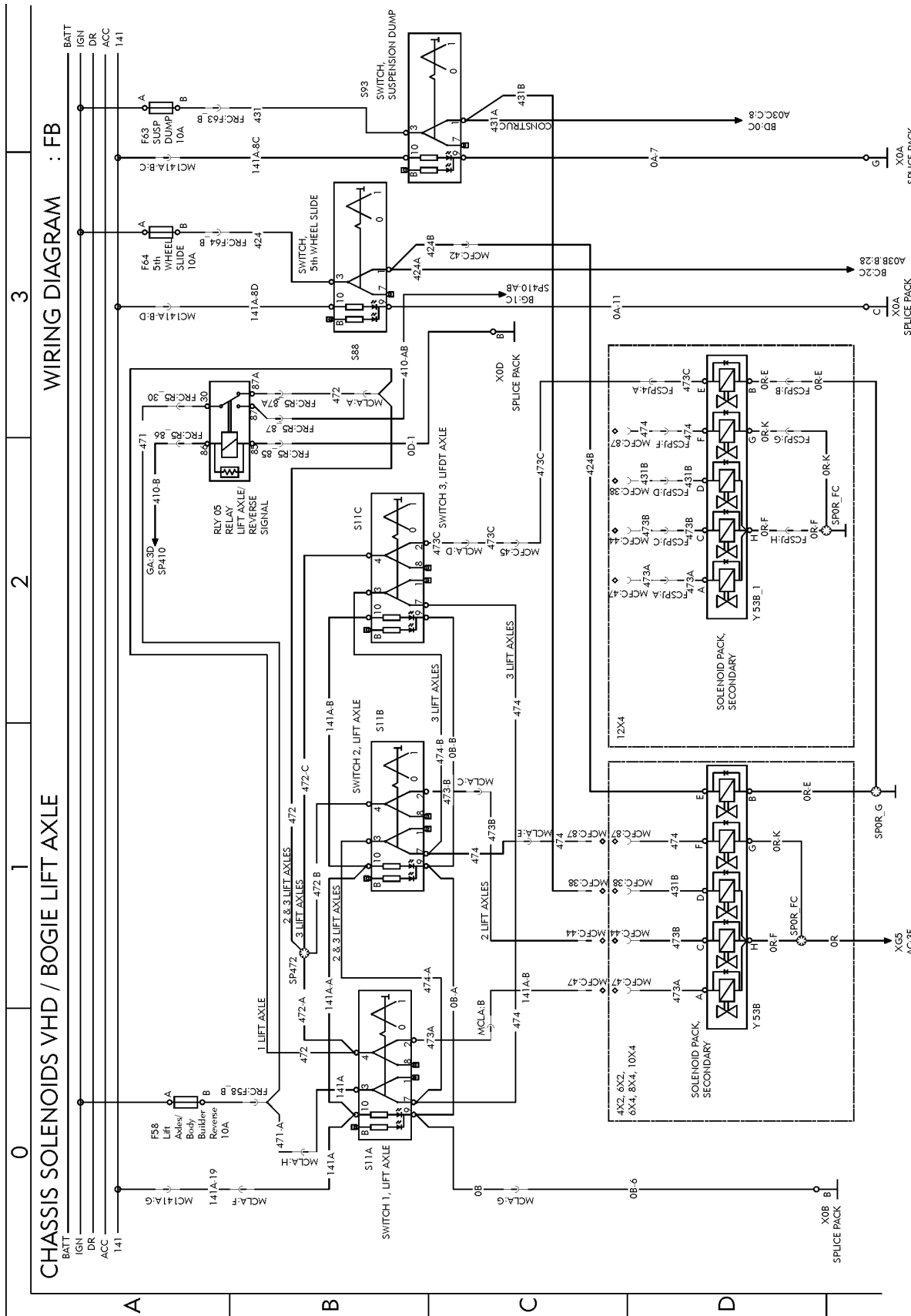

Fig. 34: FB

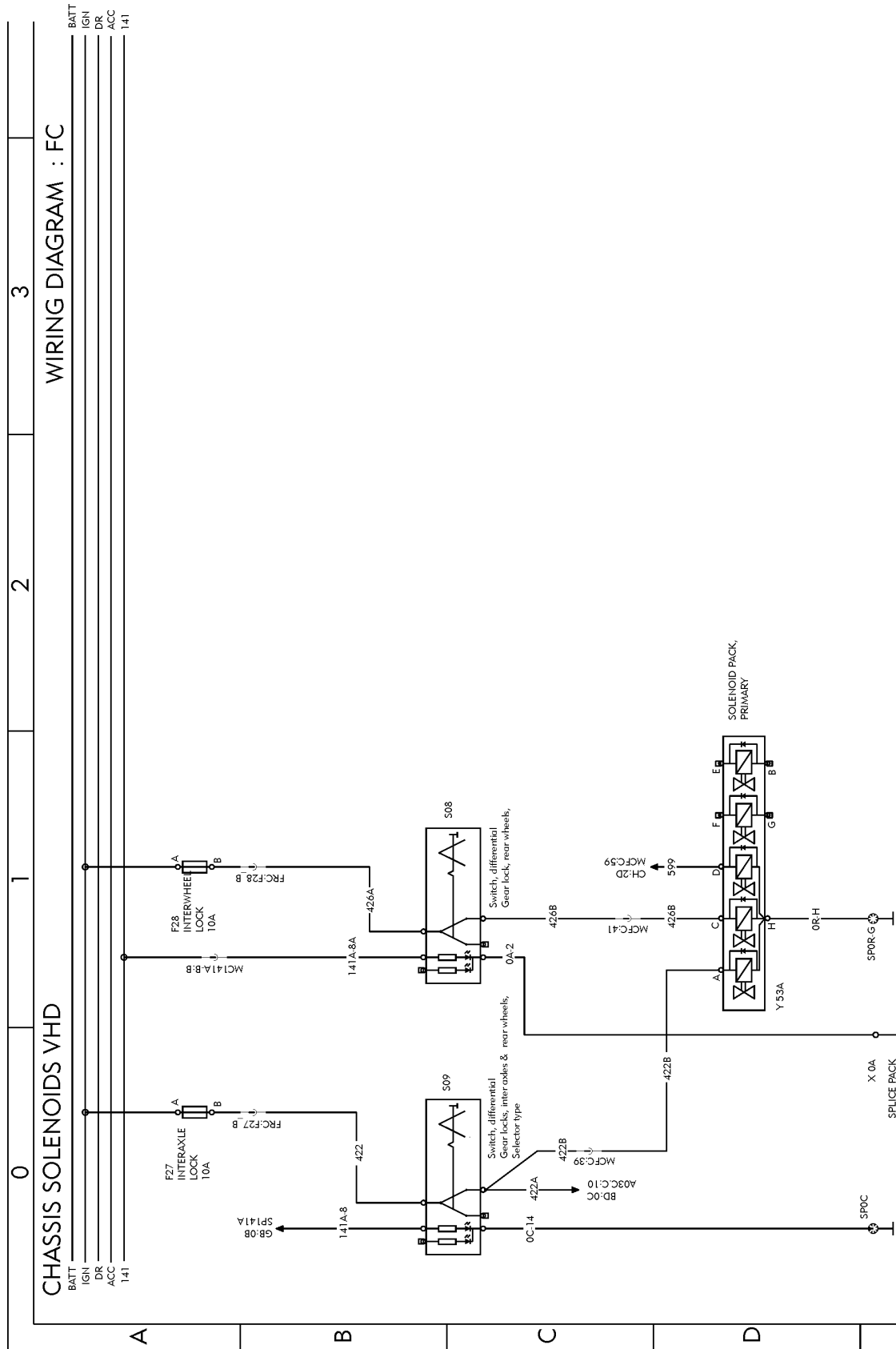

Fig. 35: FC

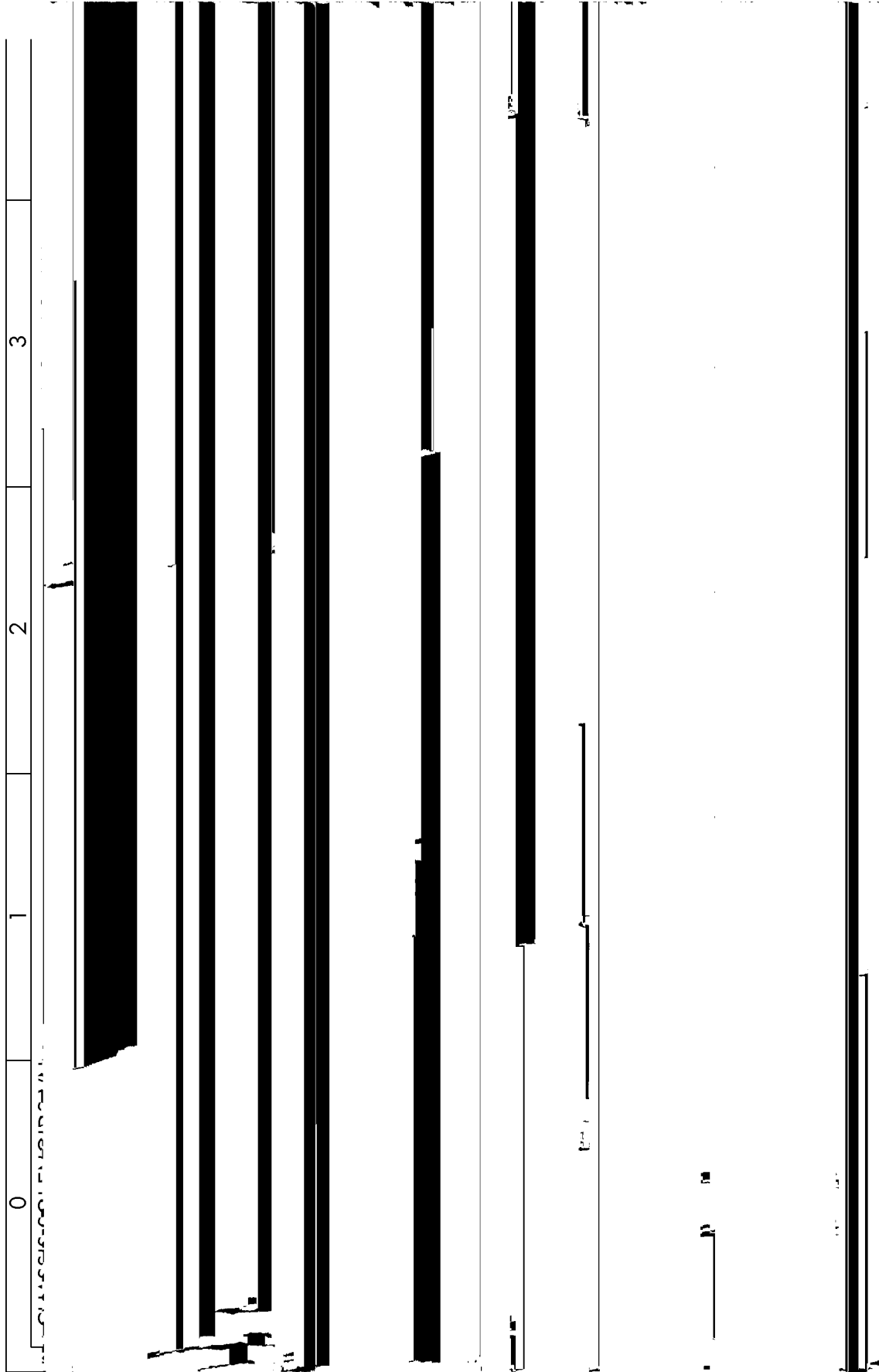

Fig. 36: FD

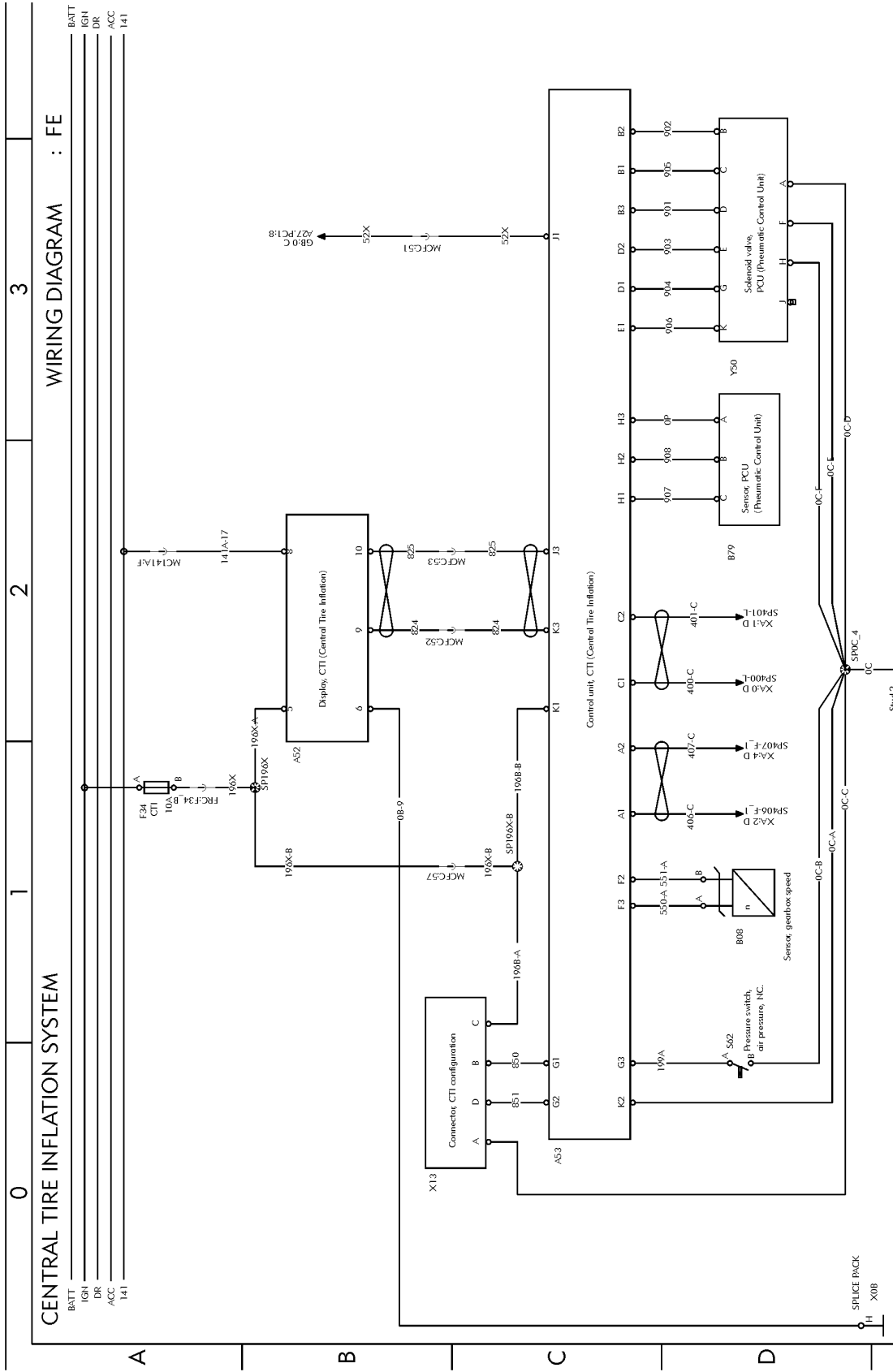

Fig. 37: FE

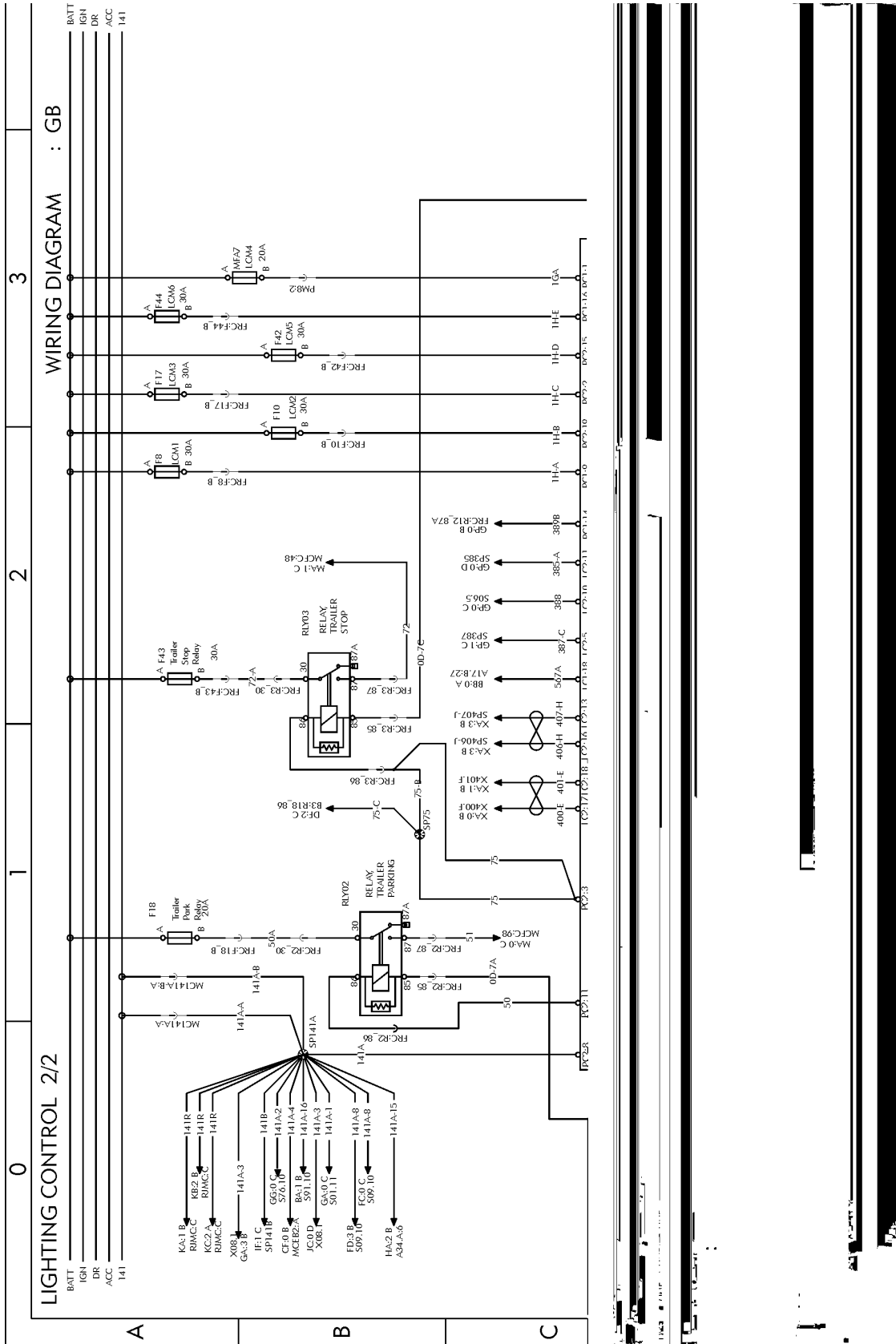

Fig. 39: GB

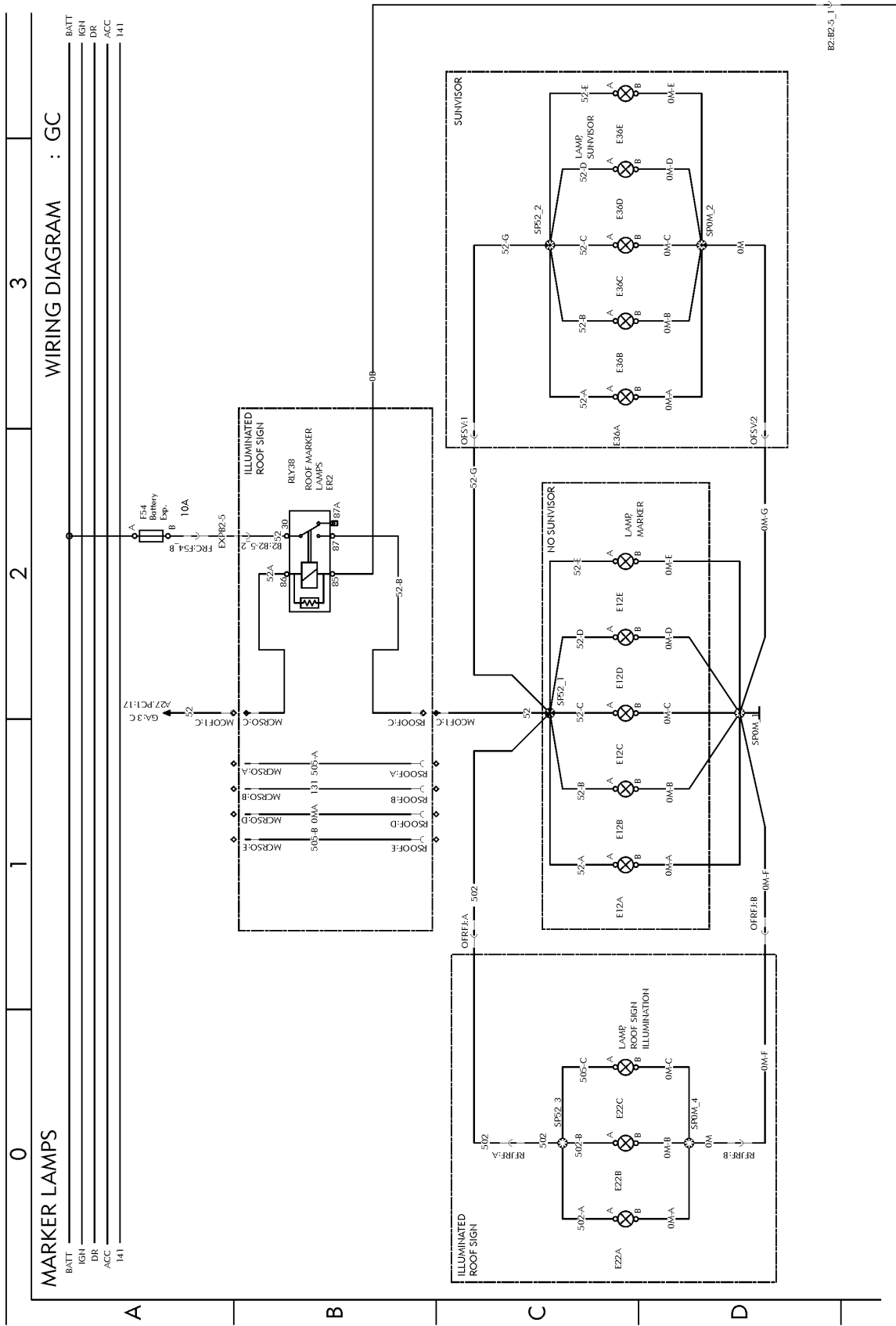

Fig. 40: GC

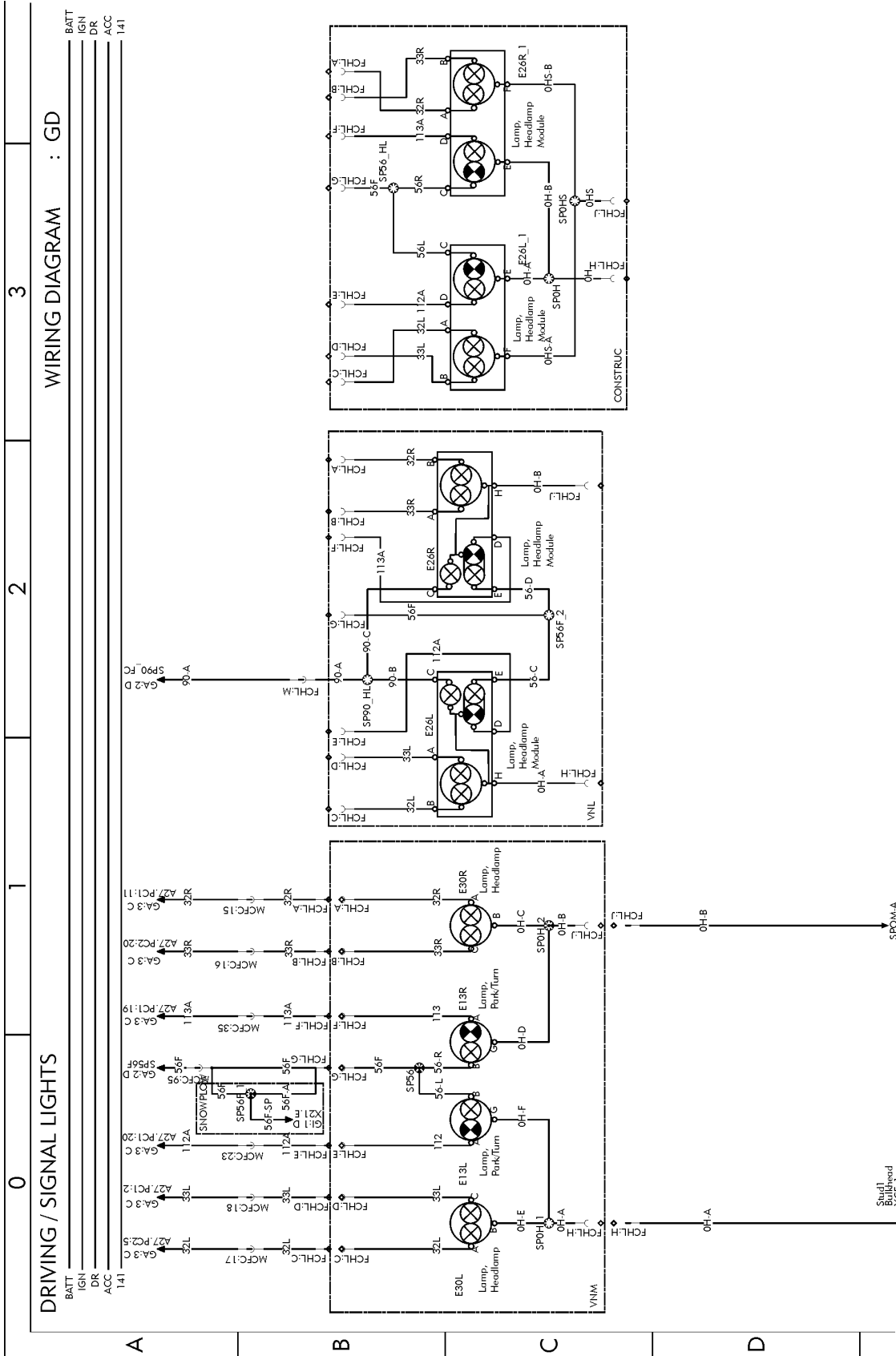

Fig. 41: GD

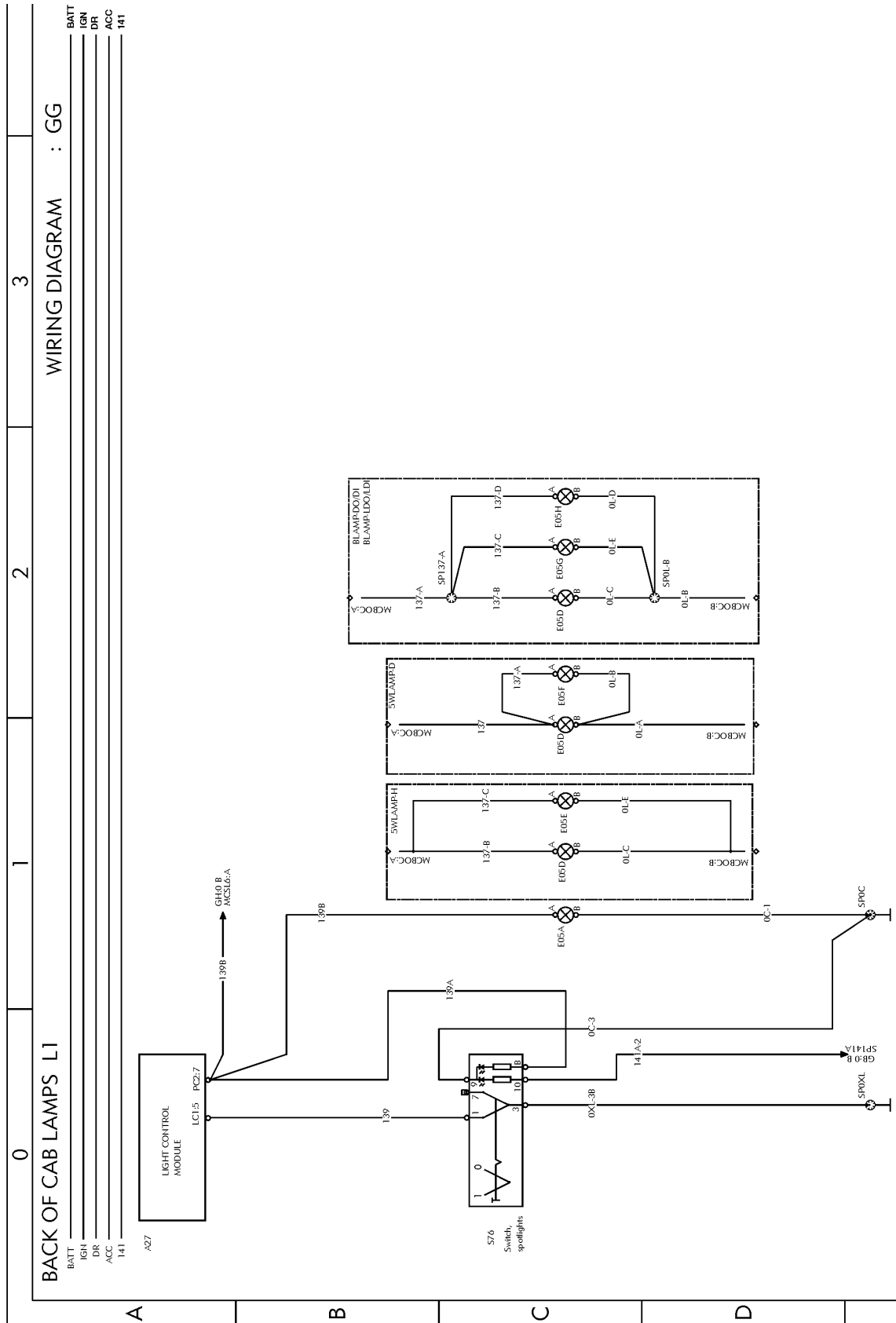

Fig. 44: GG

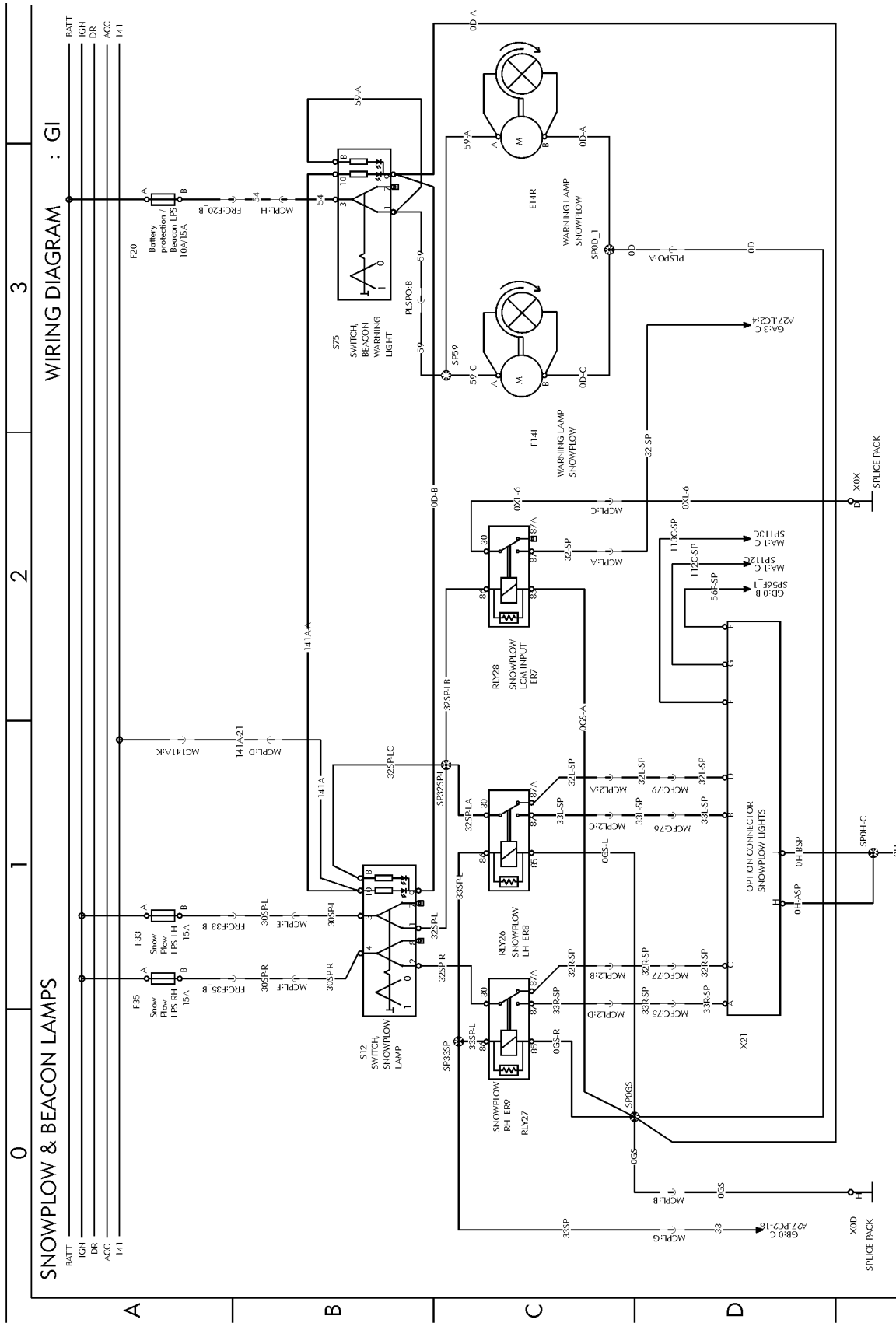

Fig. 46: GI

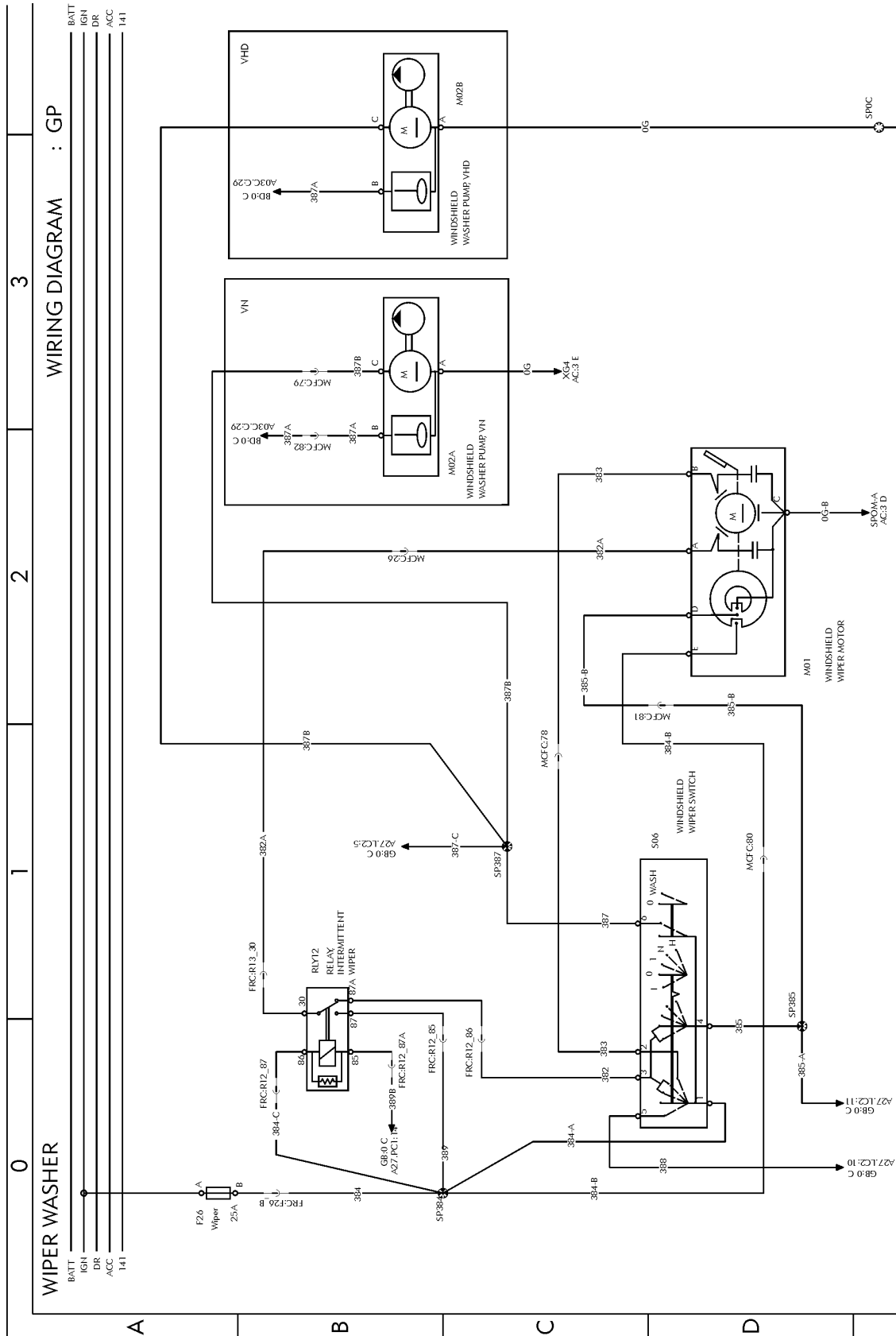

Fig. 47: GP

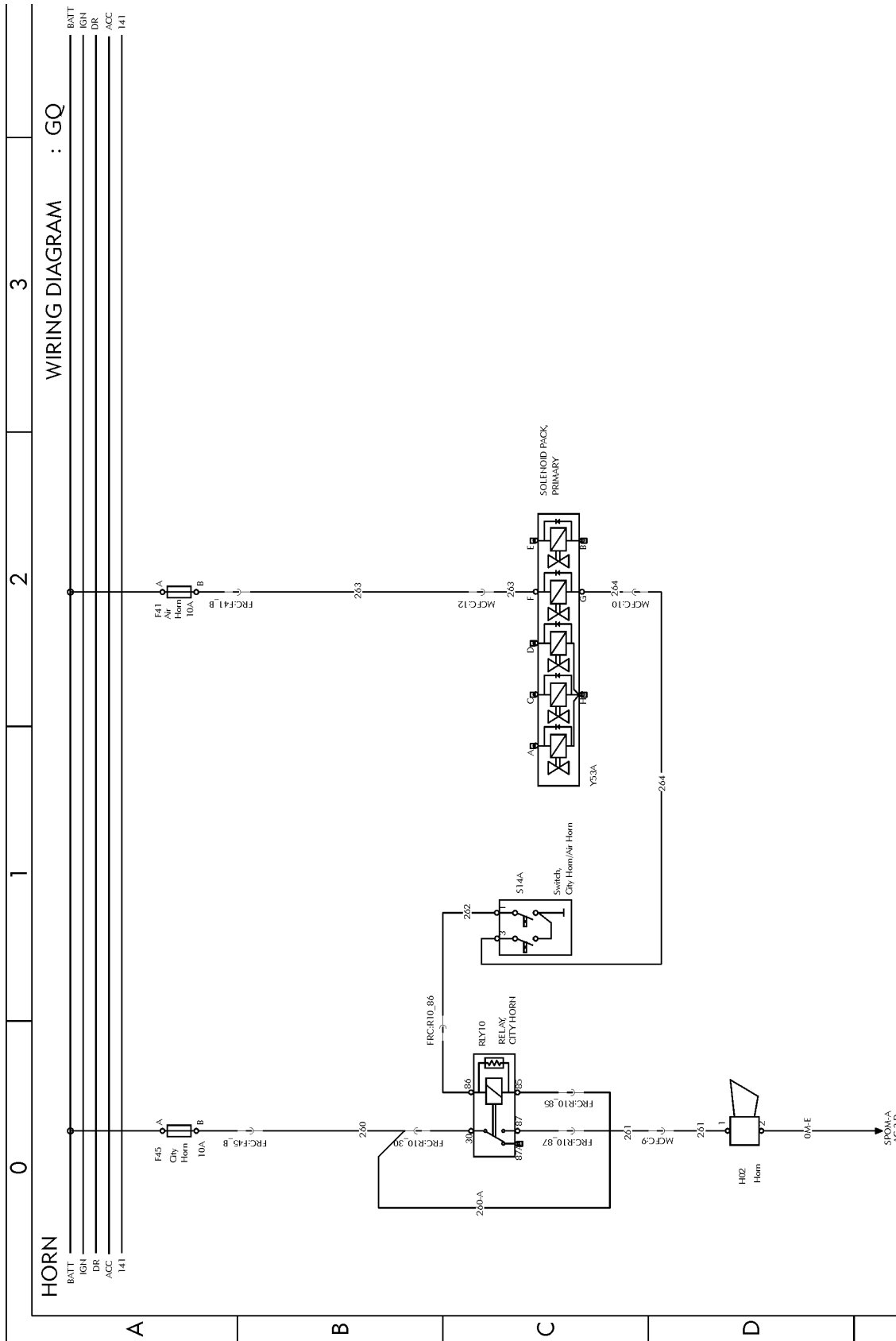

Fig. 48: GQ

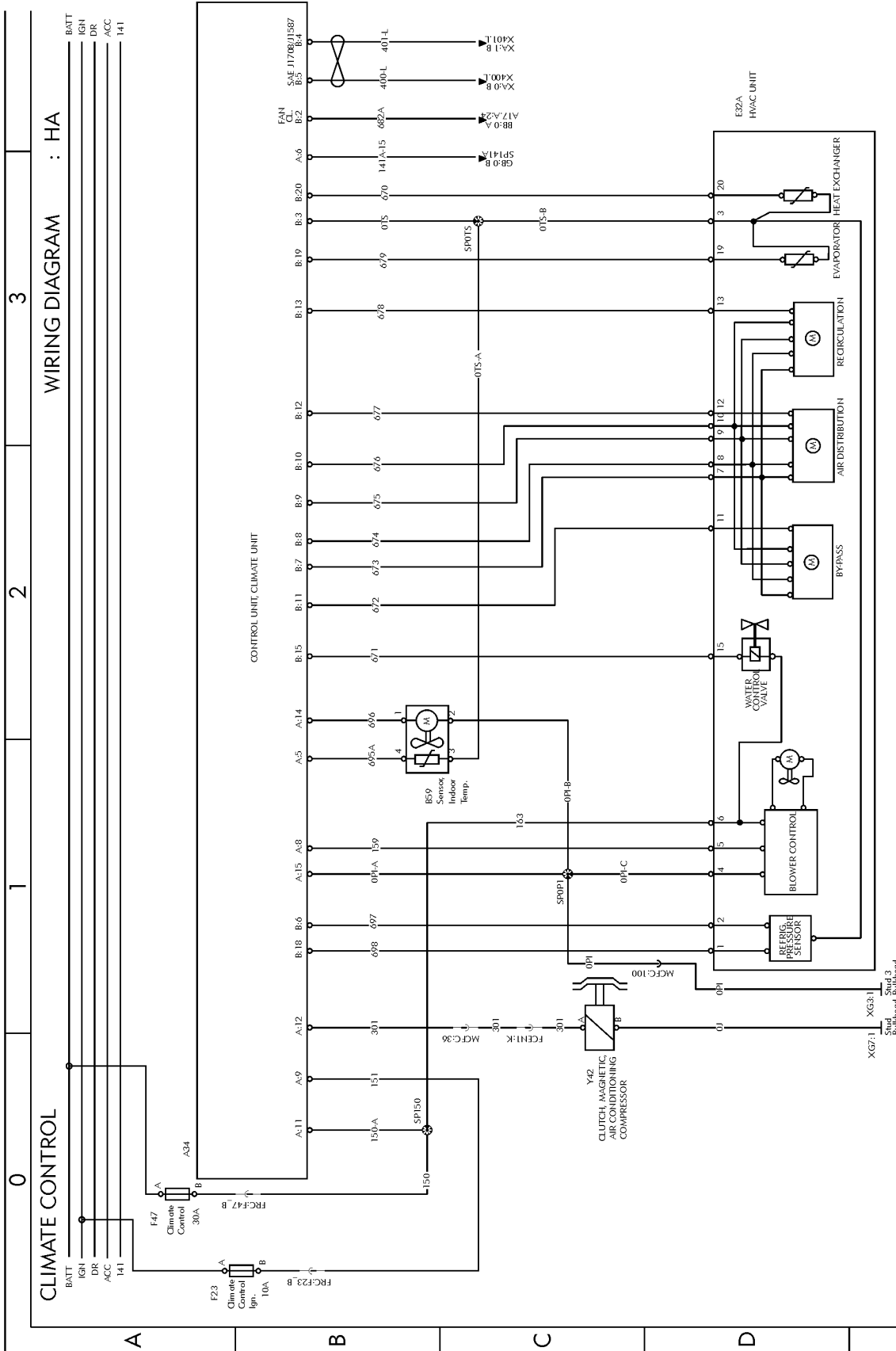

Fig. 49: HA

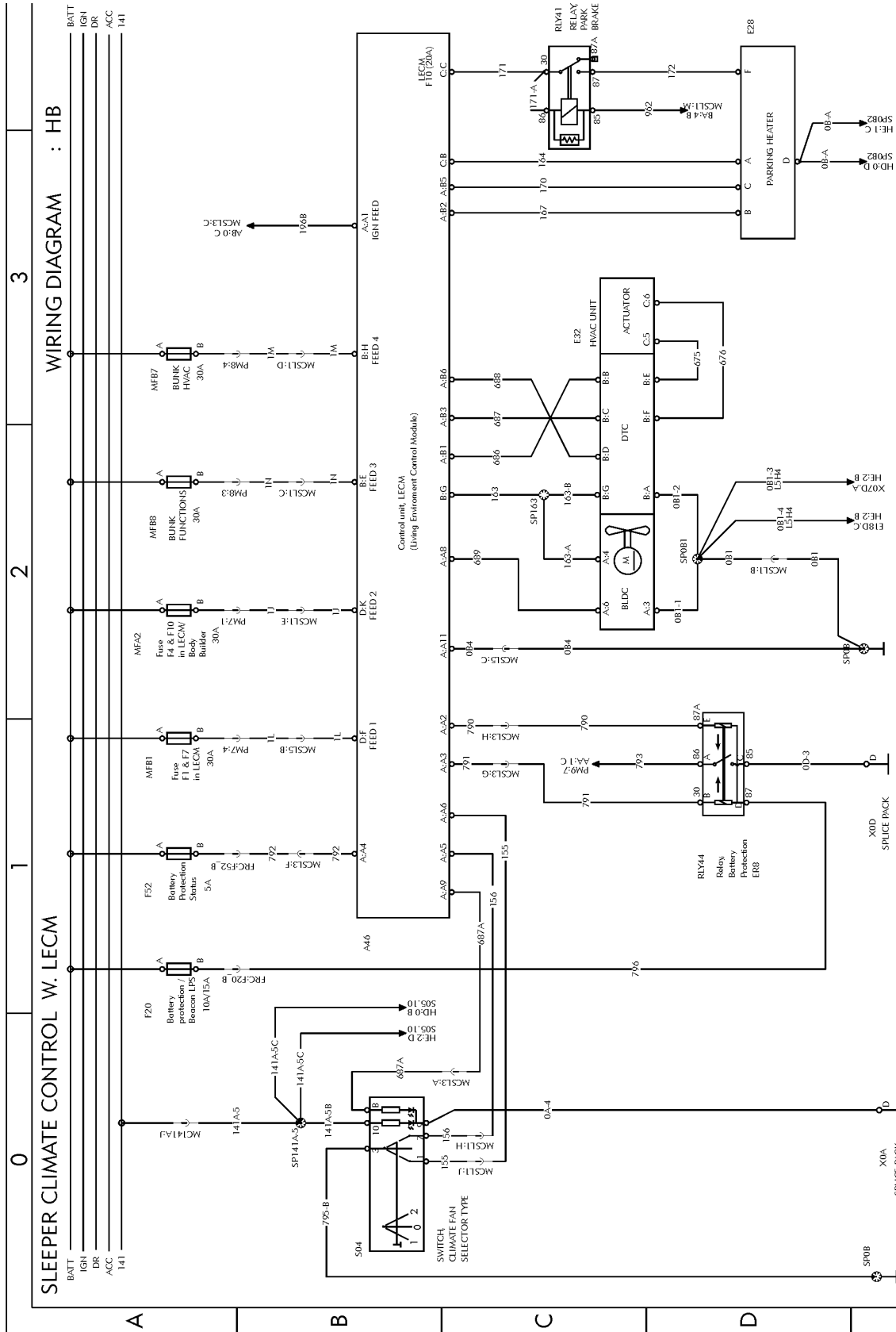

Fig. 50: HB

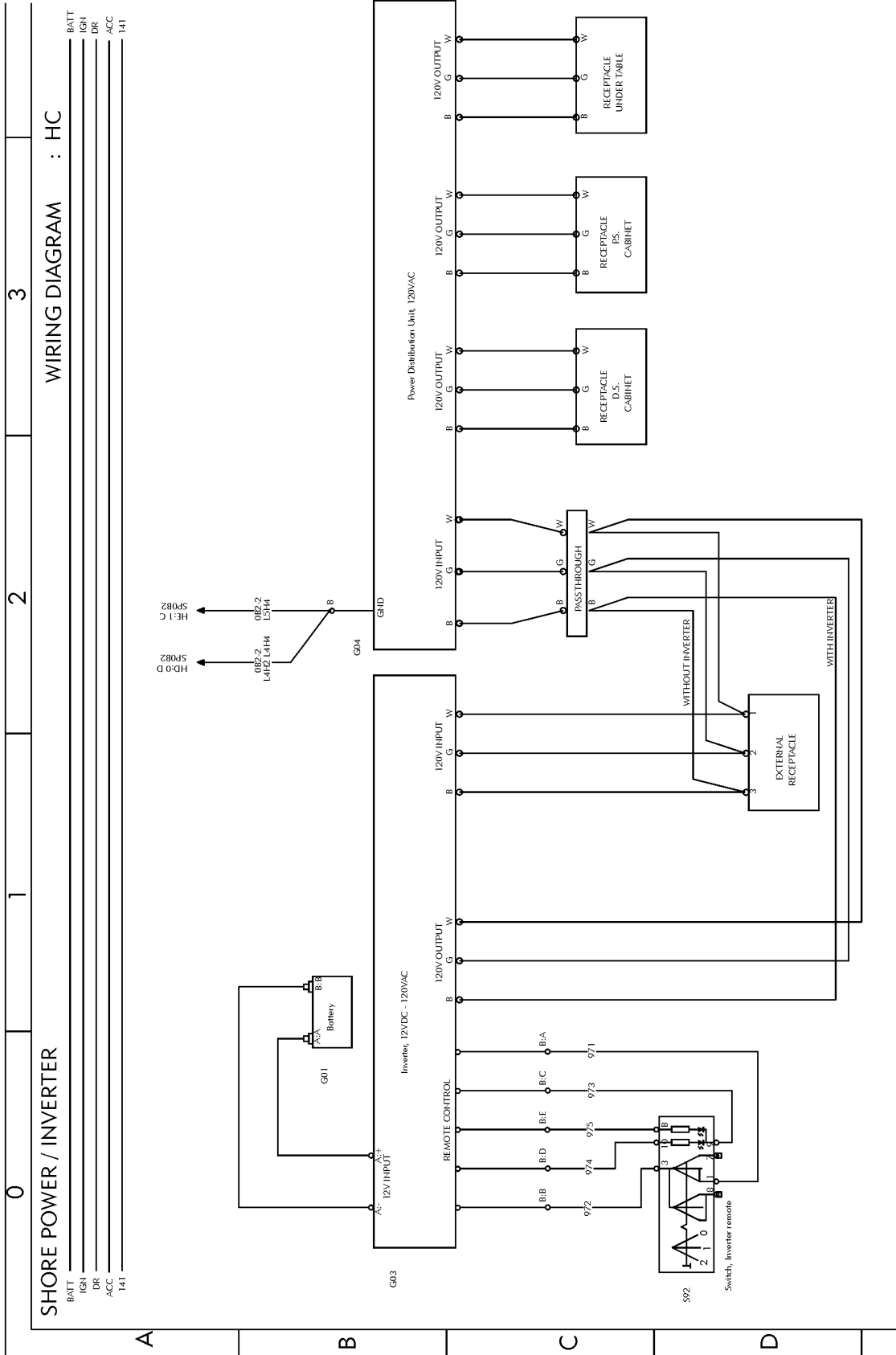

Fig. 51: HC

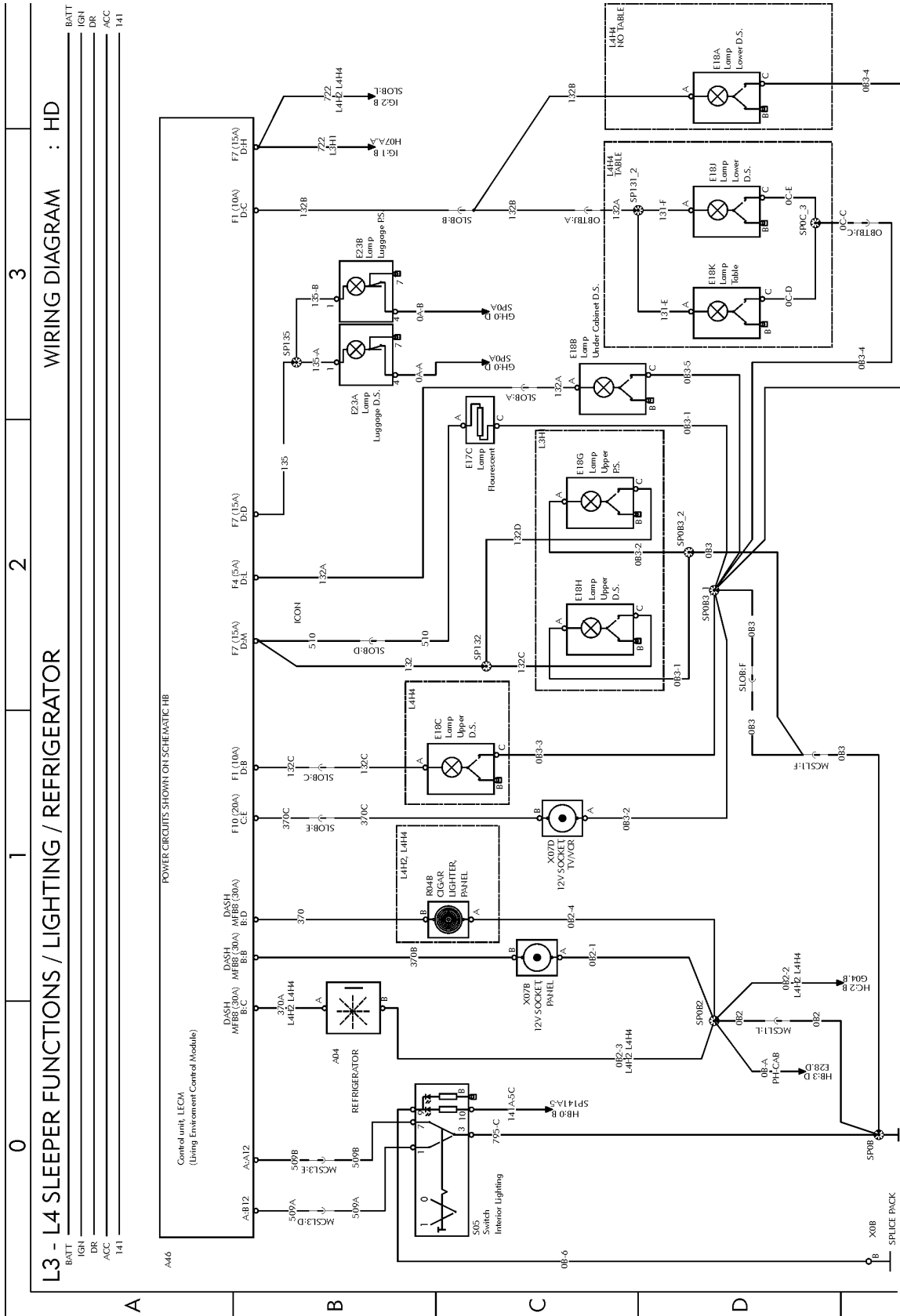

Fig. 52: HD

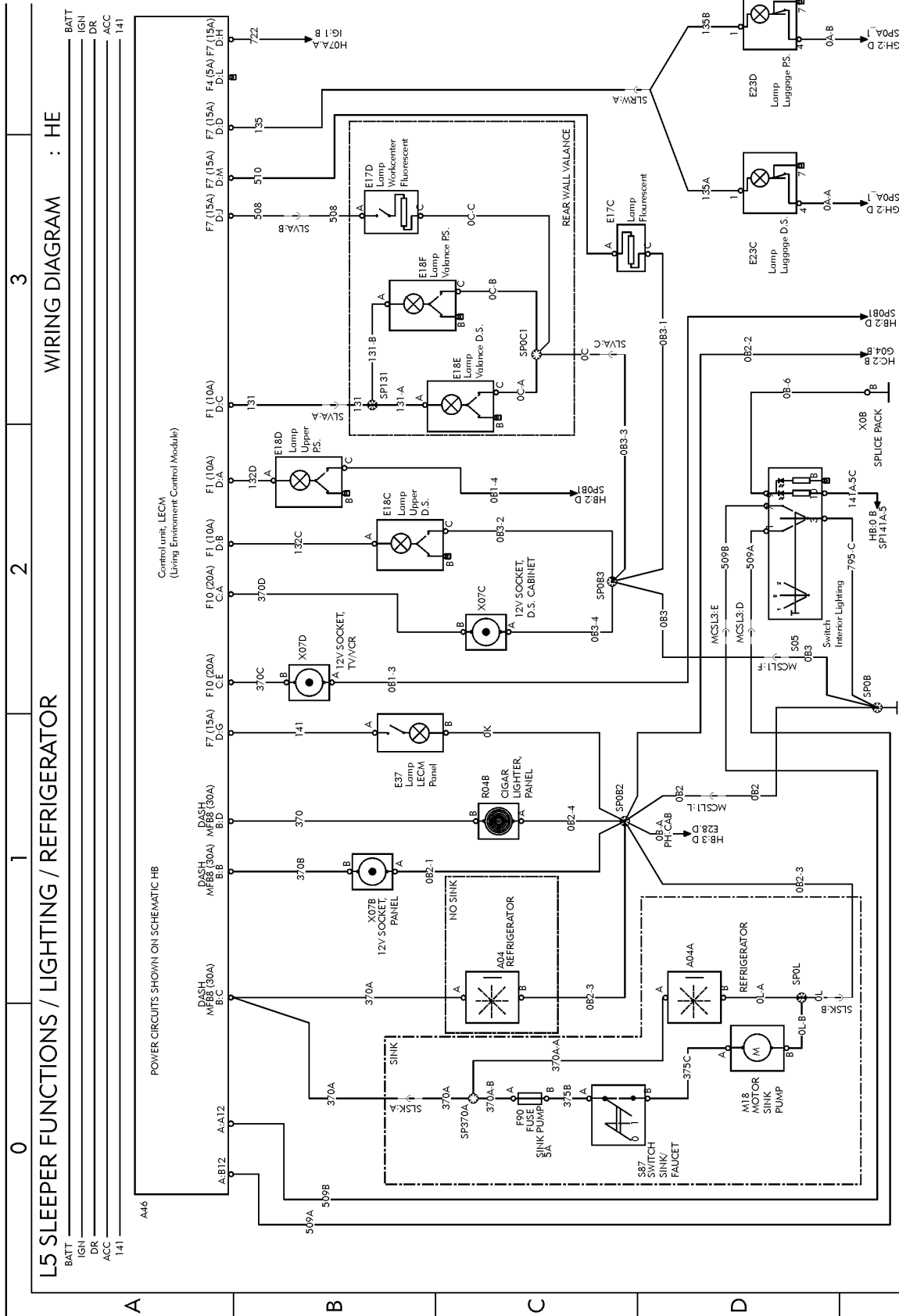

Fig. 53: HE

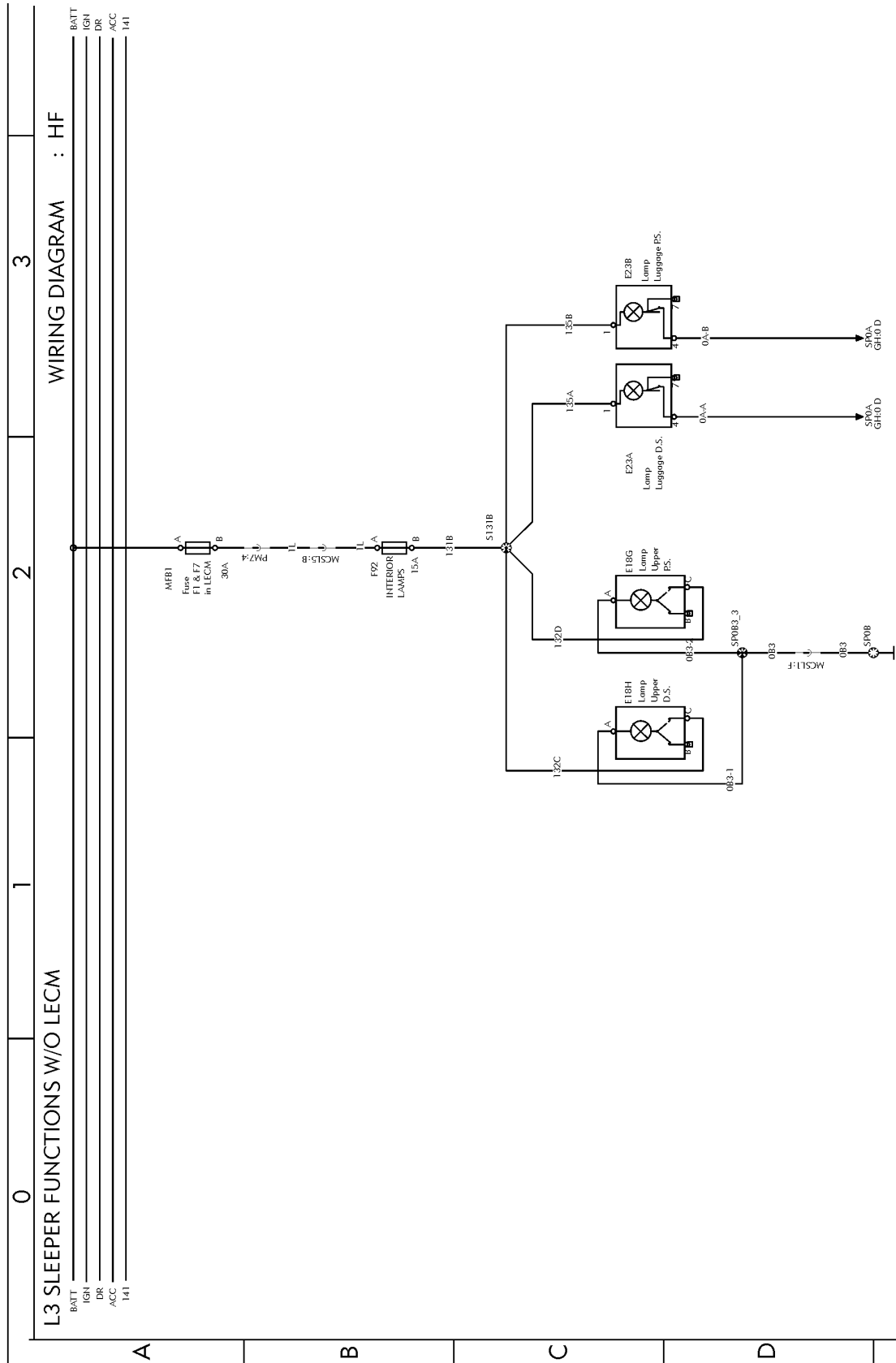

Fig. 54: HF

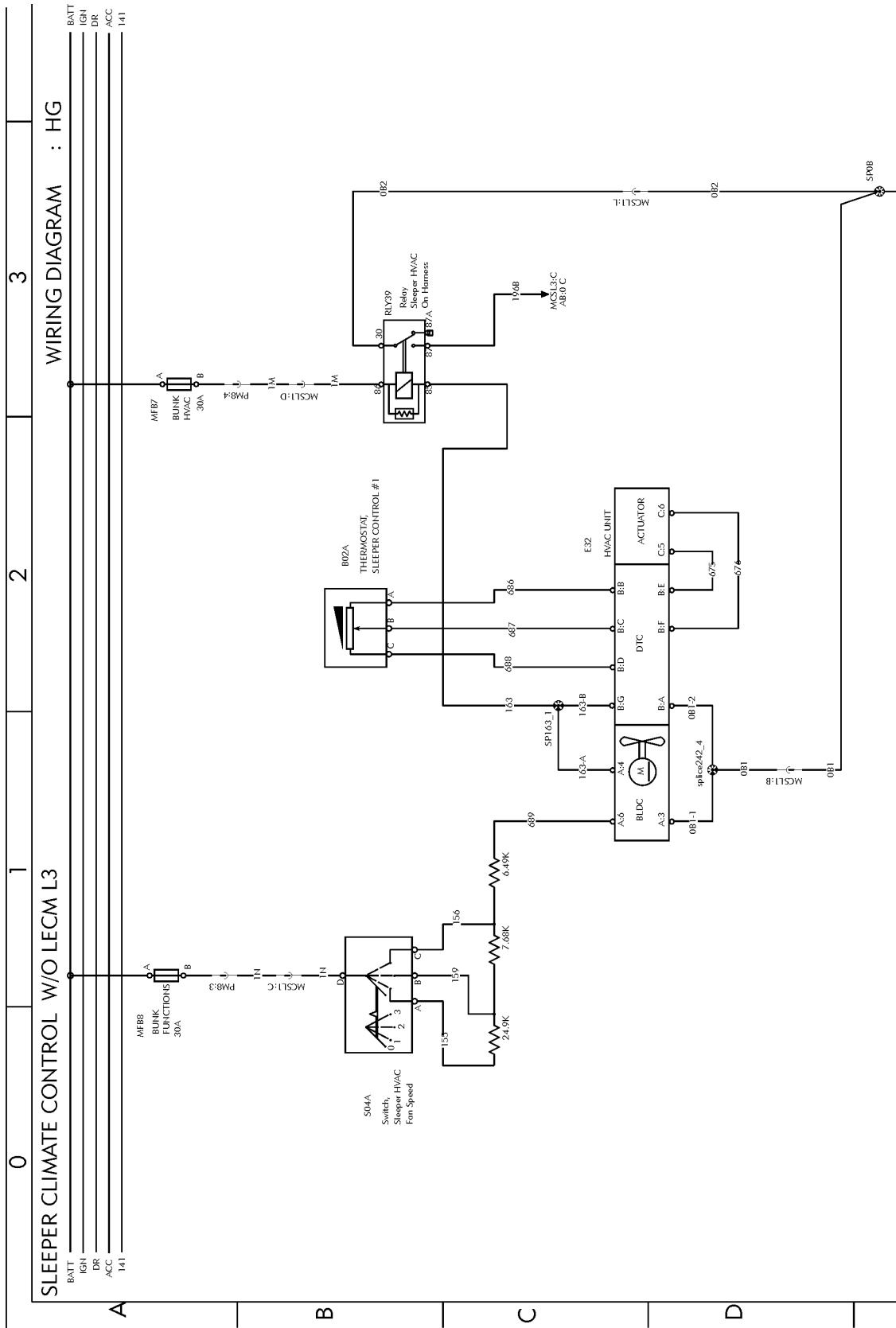

Fig. 55: HG

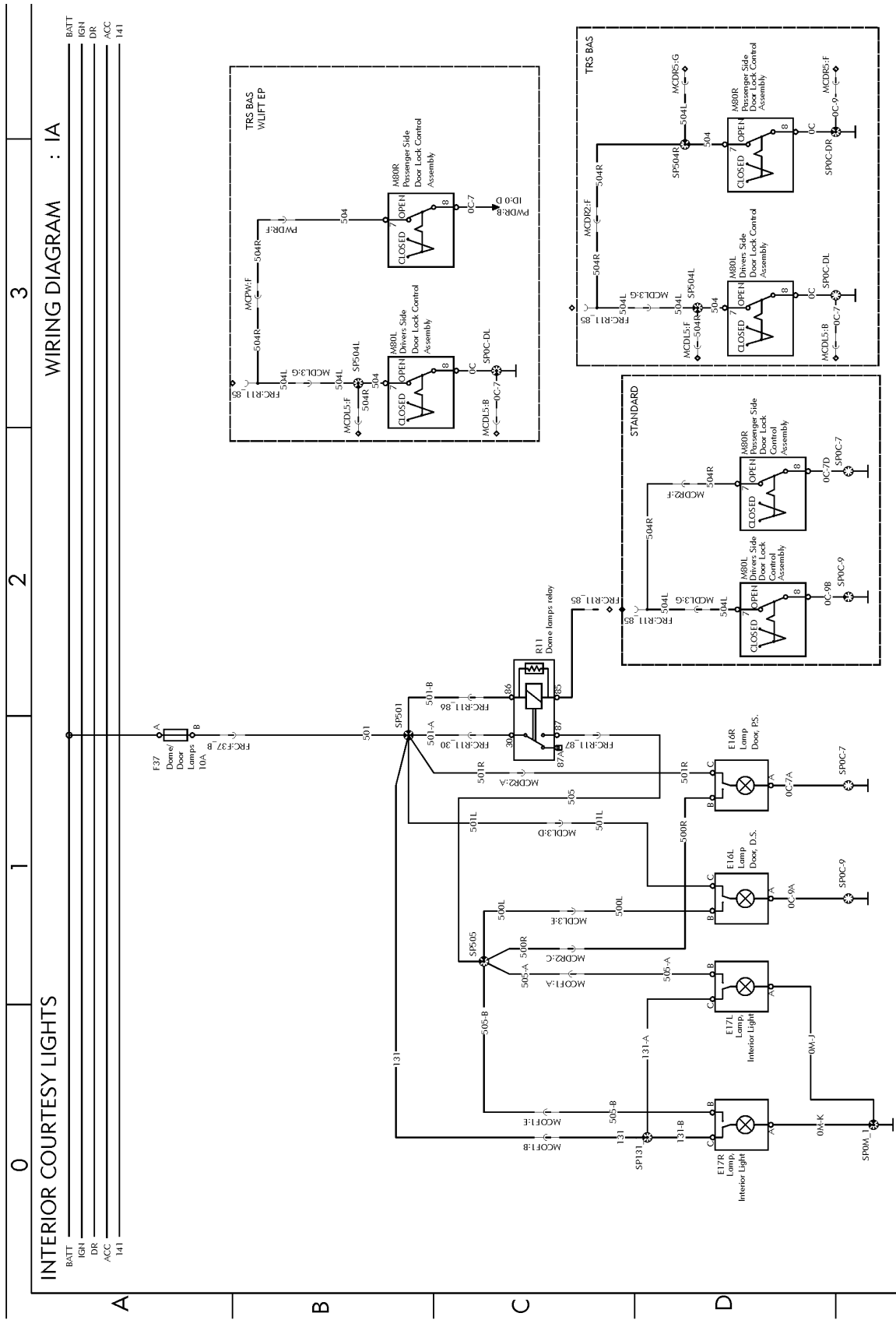

Fig. 56: IA

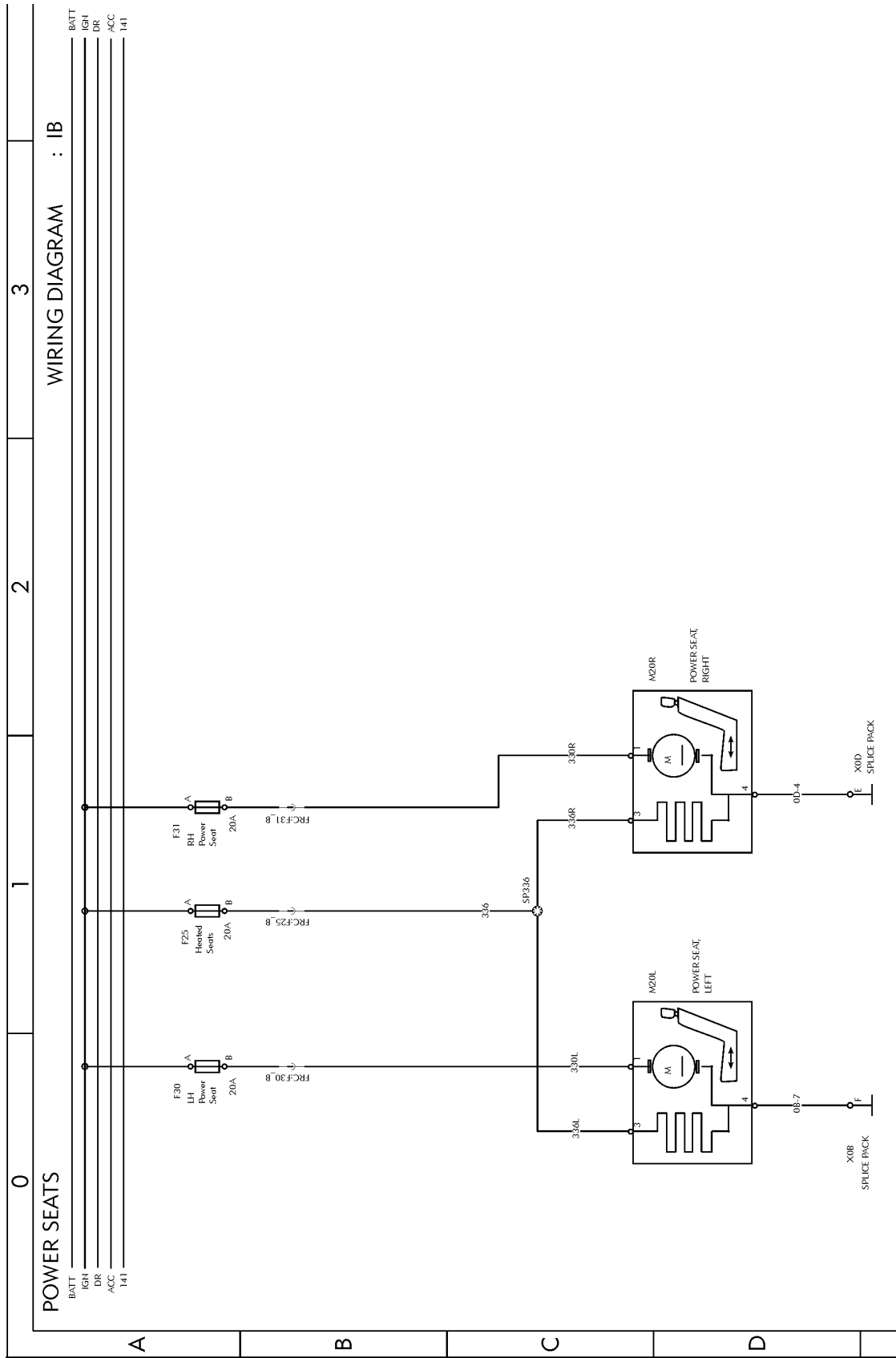

Fig. 57: IB

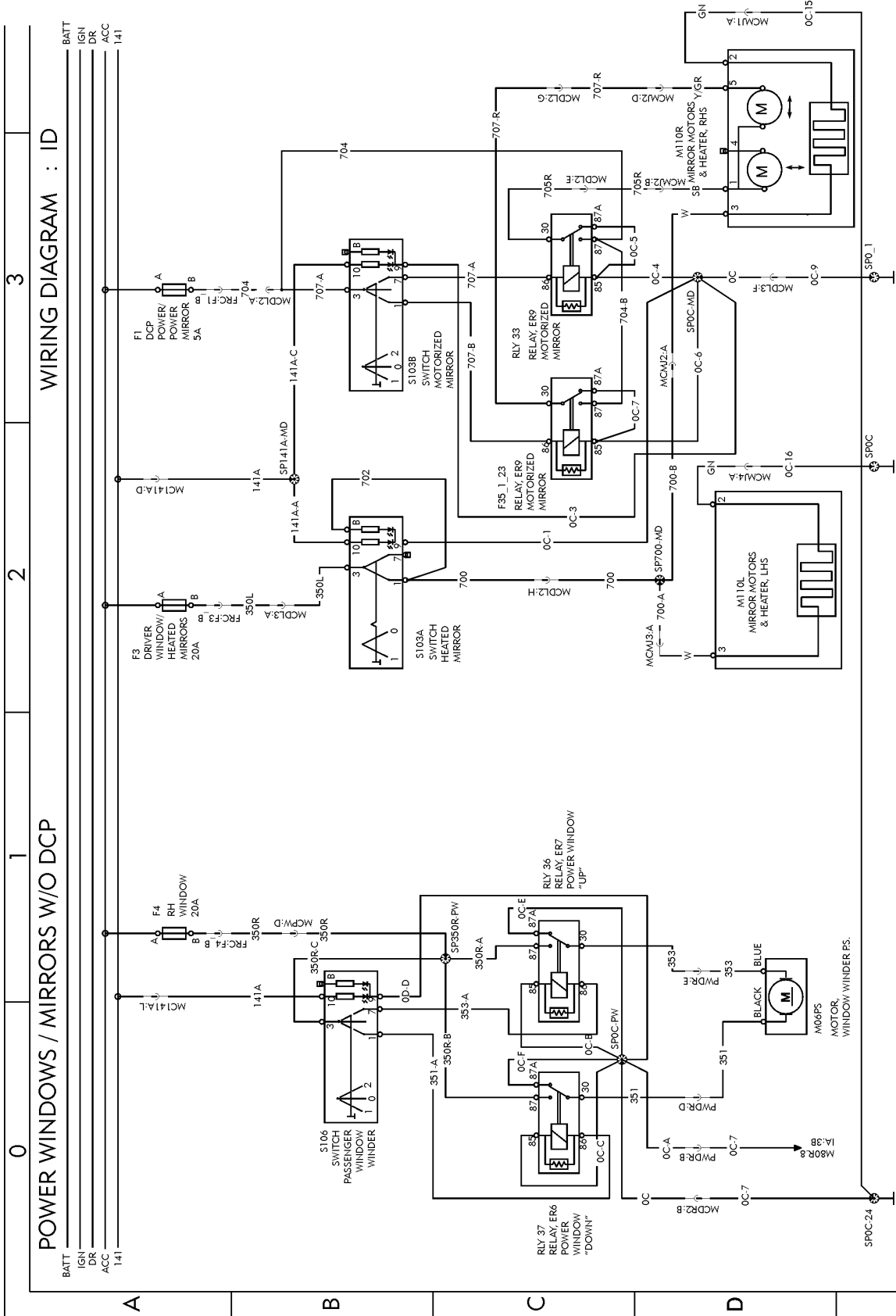

Fig. 59: ID

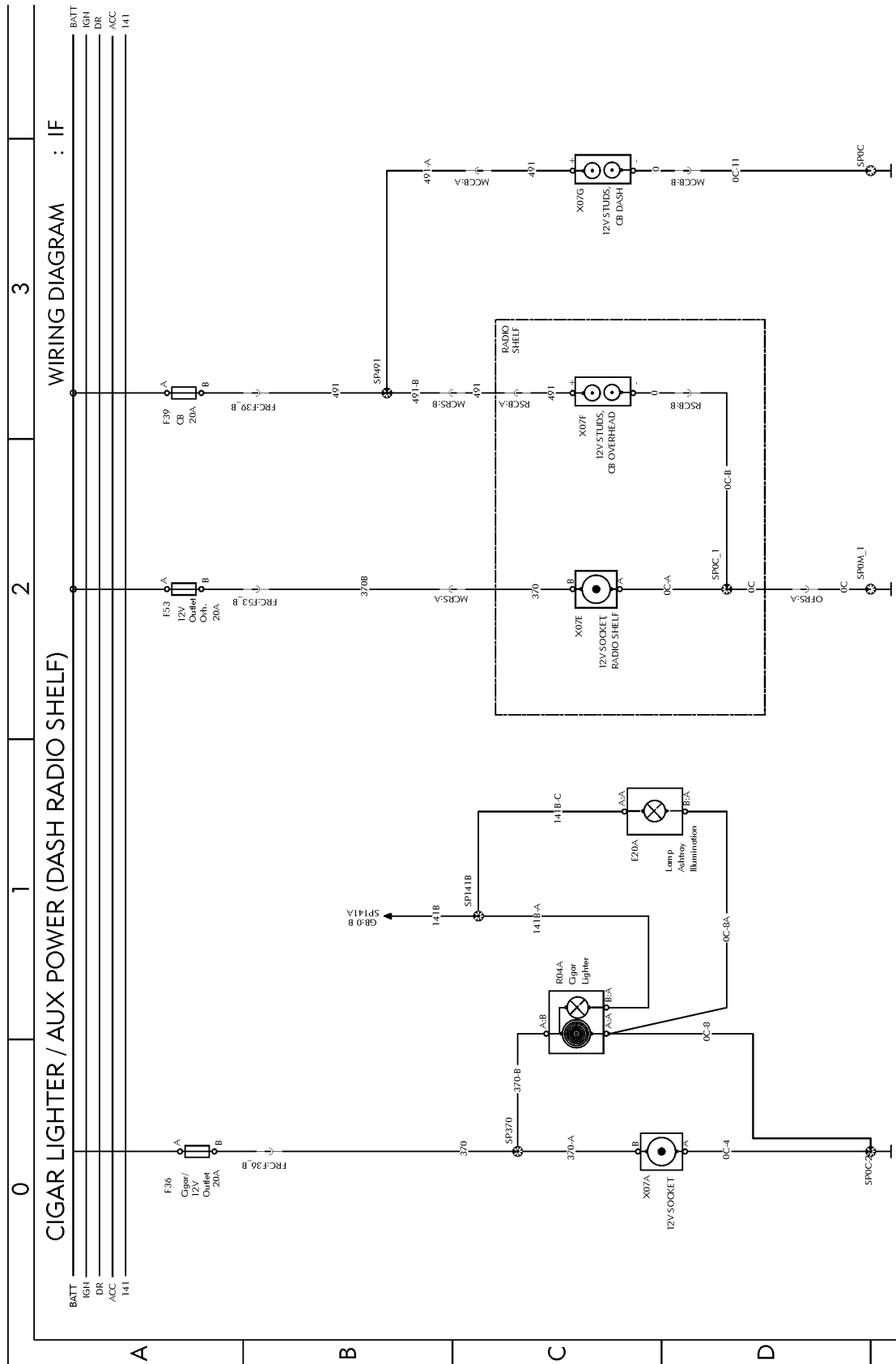

Fig. 61: IF

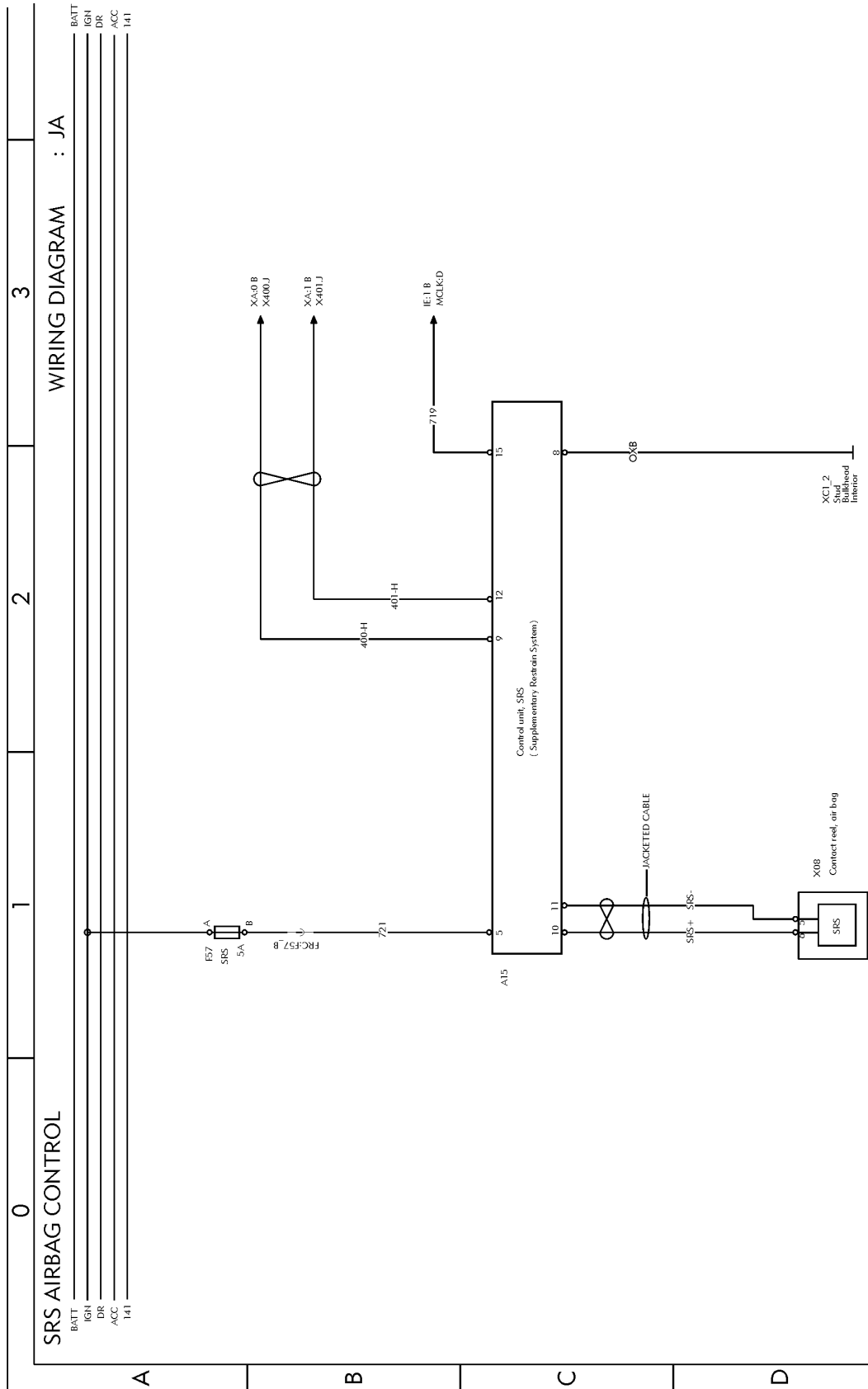

Fig. 63: JA

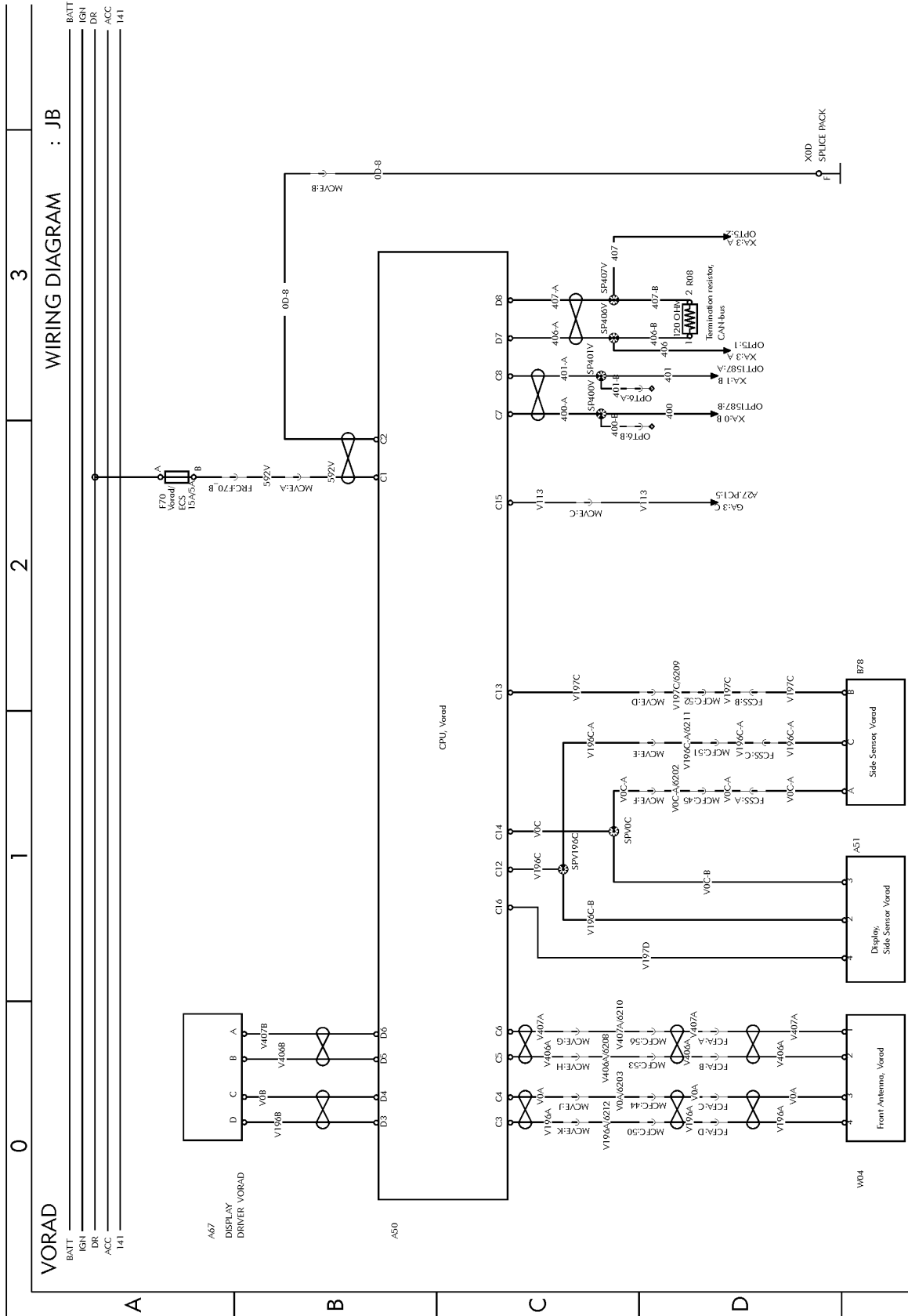

Fig. 64: JB

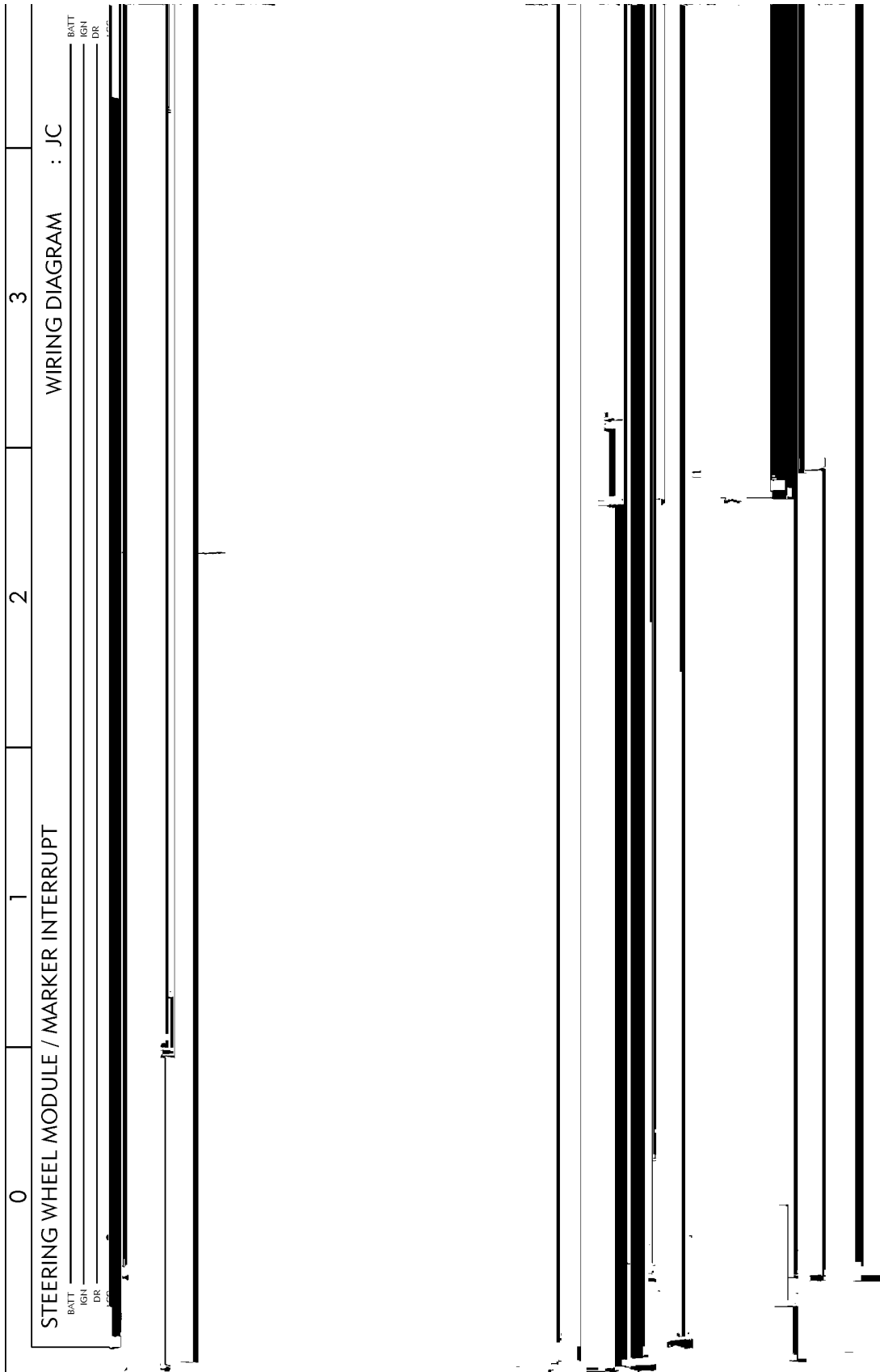

Fig. 65: JC

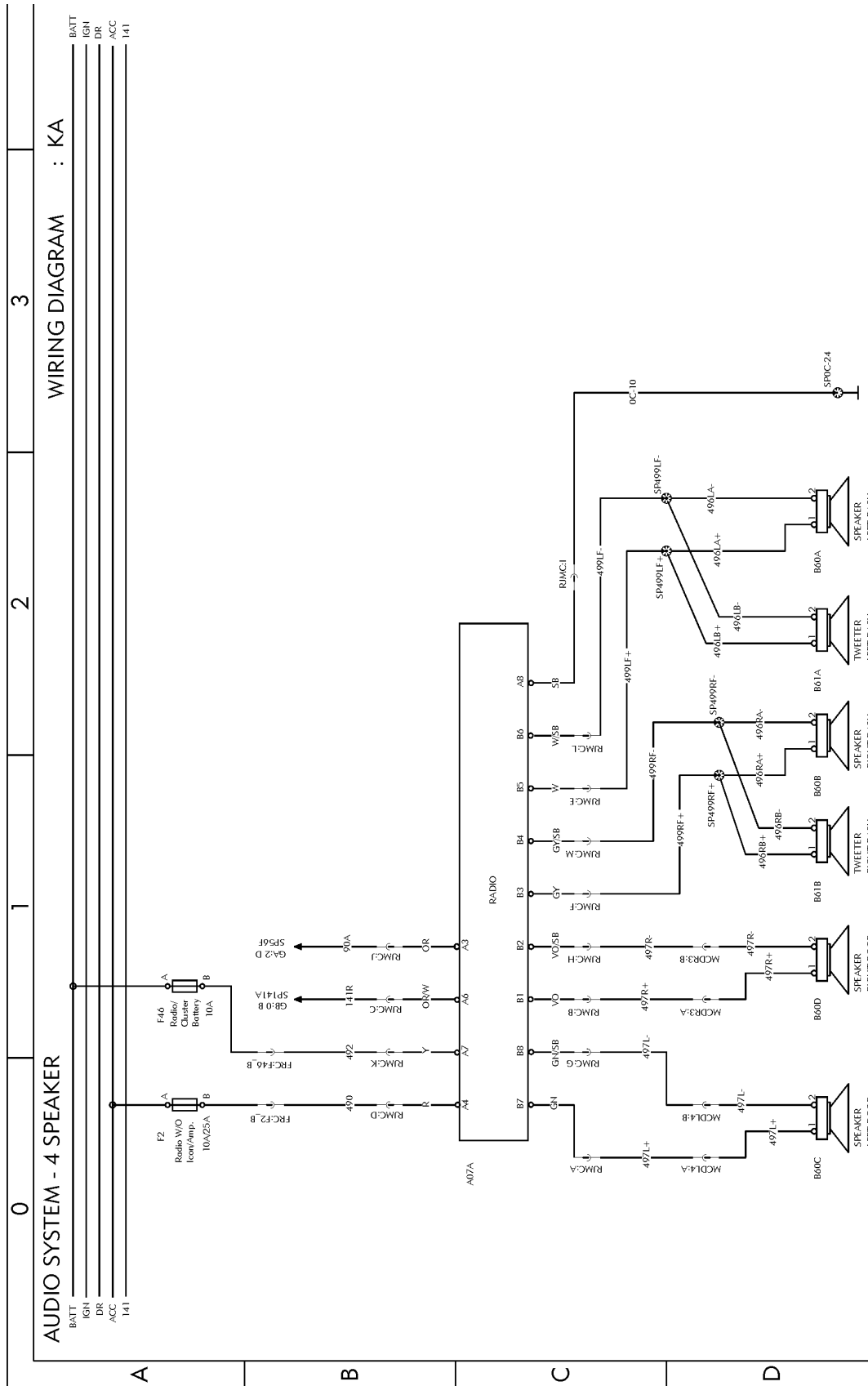

Fig. 66: KA

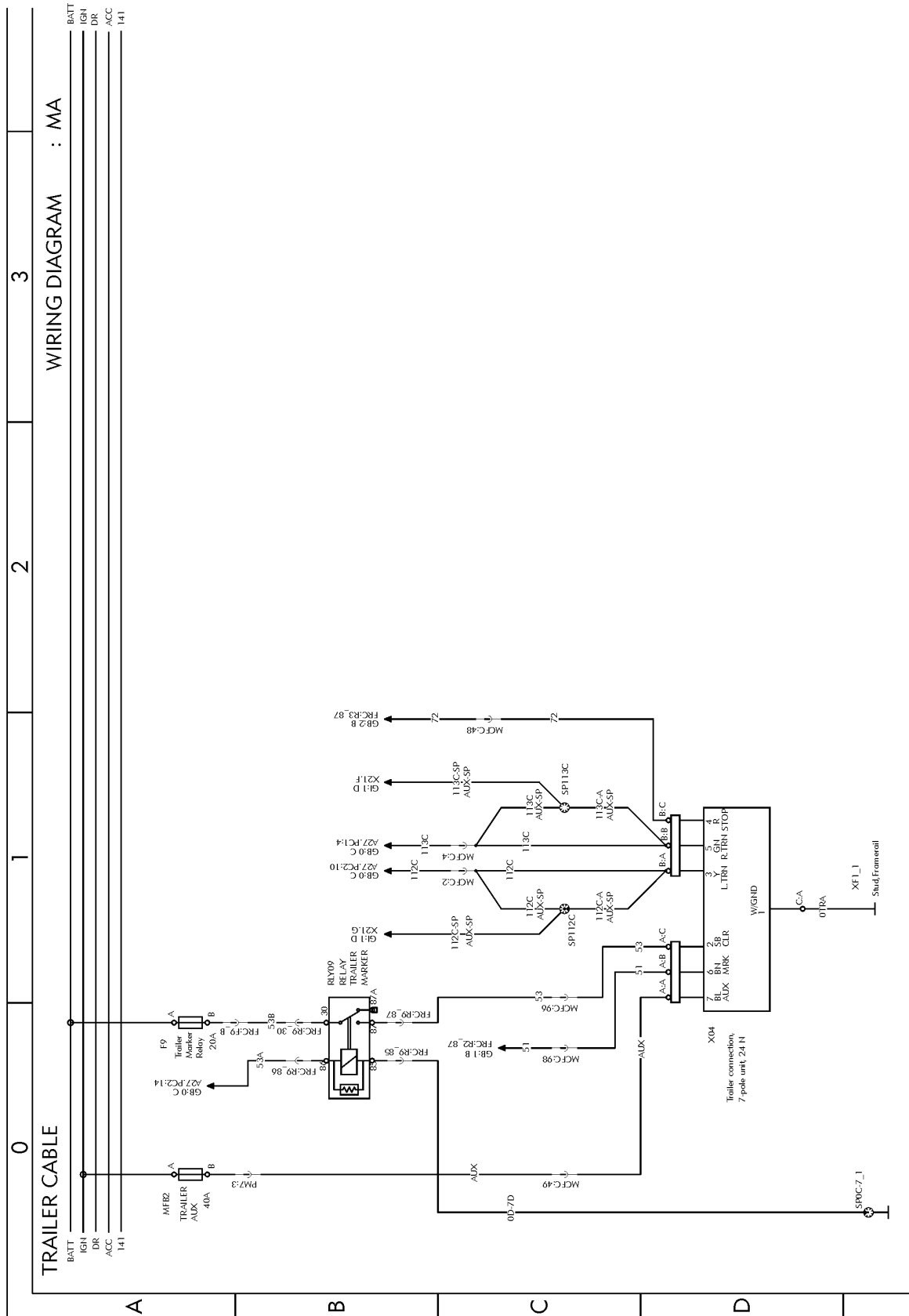

Fig. 69: MA

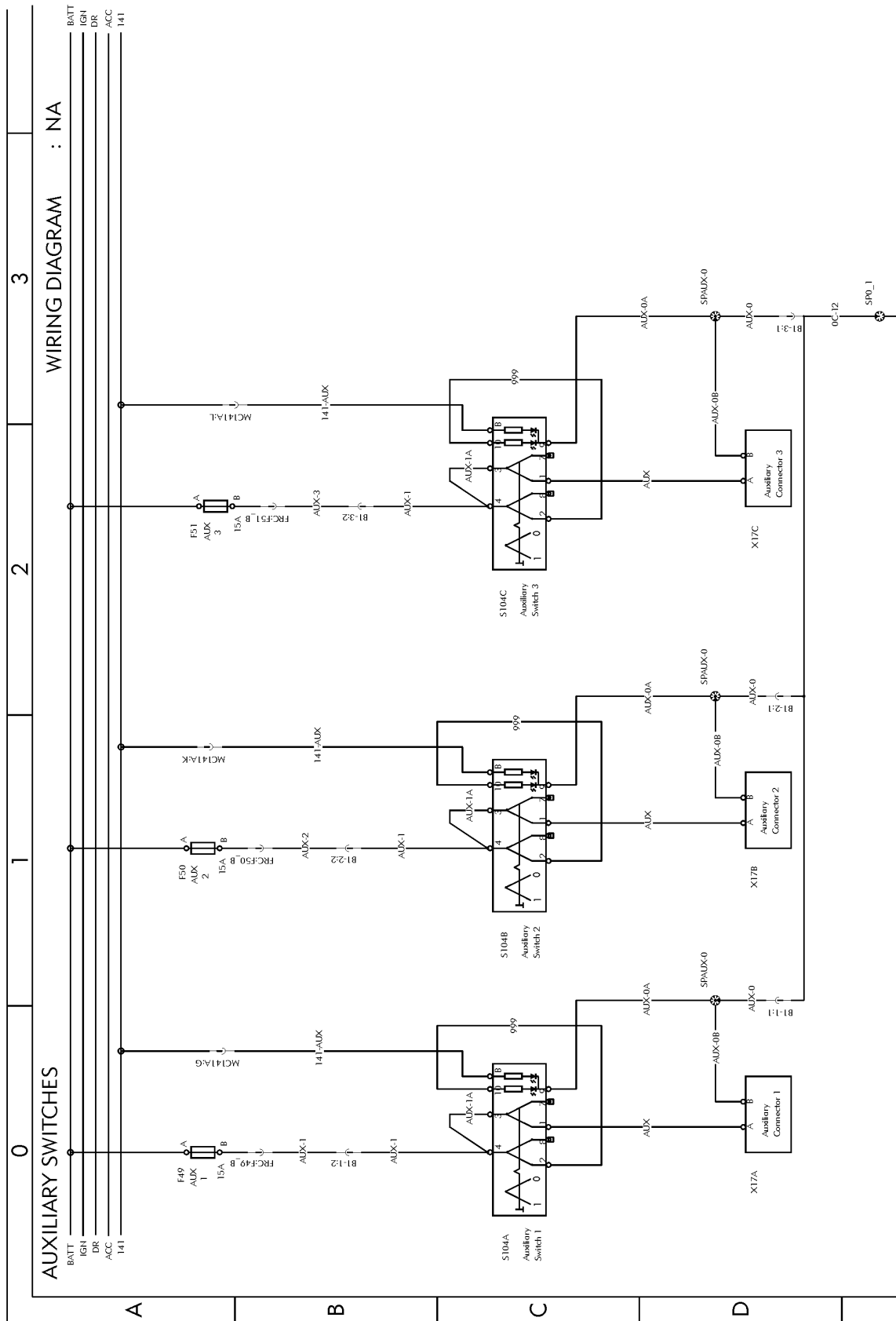

Fig. 70: NA

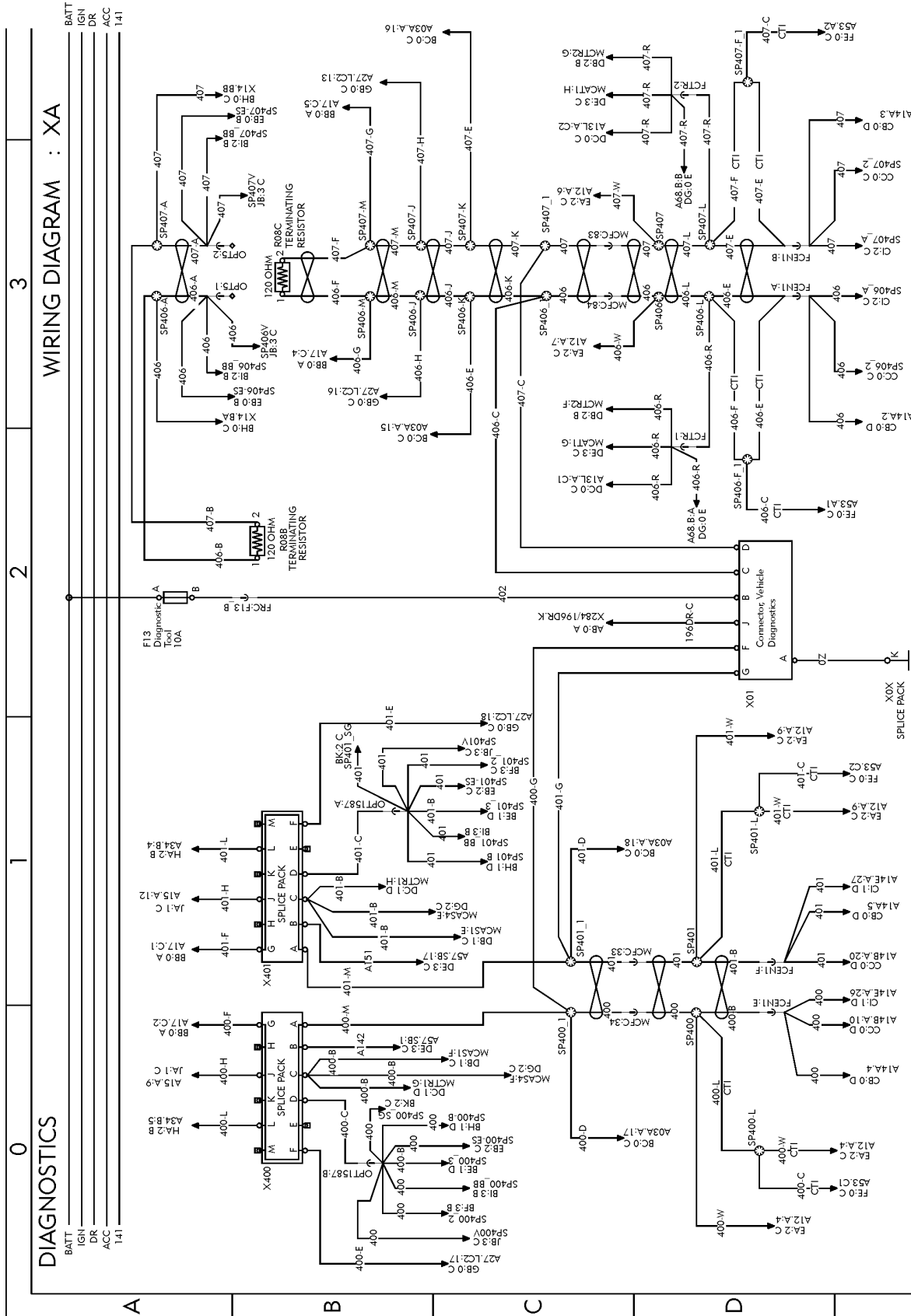

Fig. 71: XA

Illustrations

Illustration Index, Wiring Harnesses

Number	Description	Page
Cab Interior		
	Fuse and Relay (TEC) Center, Main Cab Harness	"Fuse and Relay Center, Main Cab Harness (including Bodybuilder Module)" page 80
	Cab Wiring Passthrough	"Cab Wiring Passthrough" page 81
	Dash Switches, VN	"Dash Switches, VN" page 82
	Dash Switches, VHD	"Dash Switches, VHD" page 83
	Dash Harness and Cab Wiring Passthrough	"Dash Harness and Cab Wiring Passthrough" page 84
	Dash Harness, Road Relay	"Dash Harness, Road Relay" page 85
	Dash Harness, Qualcomm	"Dash Harness, Qualcomm" page 86
	Dash Harness, Snowplow Lights	"Dash Harness, Snow Plow/ Beacon Lights Option" page 87
	Dash Overhead Shelf Harness and CB Power	"Front Overhead Shelf/CB Power Harness" page 88
	Radio Harness	"Radio Harness" page 89
	Steering Column Harness	"Steering Column Harness, Including Stalk Switches" page 90
	Cab Floor Harnesses, Front	"Cab Floor Harnesses, Front" page 91
	Cab Floor Harness, Bodybuilder Option	"Cab Floor Harness, Bodybuilder Option (VHD)" page 92
	Sleeper Control Panel	"Sleeper Control Panel (LECM)" page 106
	Rear Cab Harness, VN430	"Rear Cab Harness, VN430" page 93
	Rear Cab Harness, VN630	"Rear Cab Harness, VN630" page 94
	Rear Cab Harness, VN670	"Rear Cab Harness, VN670" page 95
	Rear Cab Harness, VN780	"Rear Cab Harness, VN780" page 96
	Rear Cab, Lower Wall Harness, VN780	"Rear Cab, Lower Wall Harness, VN780" page 97
	Rear Cab Valance Harness, VN780	"Rear Cab Valance Harness, VN780" page 98
	Rear Cab Harness, Back of Cab Lights (HDI/HDO)	"Rear Cab Harness, Back of Cab Lights (HDI/HDO Variant)" page 99

Number	Description	Page
	Rear Cab Harness, Back of Cab Lights (LDI/LDO)	"Rear Cab Harness, Back of Cab Lights (LDI/LDO Variant)" page 100
	Rear Cab Harness, Fifth Wheel Light	"Rear Cab Harness, Fifth Wheel Light" page 101
	Rear Cab Harness, Fifth Wheel Light	"Rear Cab Harness, Fifth Wheel Light" page 102
	Rear Cab Harness, Fifth Wheel Light and Speakers (Daycab)	"Rear Cab Harness, Fifth Wheel Light and Rear Speakers (Daycab)" page 103
	Rear Cab Harness, Dual Fifth Wheel Light and Rear Speakers (Daycab)	"Rear Cab Harness, Dual Fifth Wheel Light and Rear Speakers (Daycab)" page 104
	Rear Cab Harness, Overhead Lights and Rear Speaker Detail	"Rear Cab Harness, Overhead Lights and Rear Speaker Detail" page 105
	Volvo Link	"Volvo Link Harness and Antennas" page 107
Doors, Cab Exterior and Lighting		
	Door Harness	"Door Harness" page 110
	Power Mirrors	"Side Mirrors" page 111
	Side Markers	"Side Markers" page 112
	Roof Sign Harness	"Roof Sign Harness" page 113
	Marker Lamps, Overhead	"Overhead Marker Lights" page 114
	Marker Lamps, Sunvisor (Daycab, VN430, VN630)	"Sunvisor Harness (Daycab, VN430 and 630)" page 115
	Marker Lamps, Sunvisor (VN670, VN780)	"Sunvisor Harness (VN670 and 780)" page 116
	Trailer Cable Harness	"Trailer Cable Connections" page 117
	Headlight Harness, VHD	"Headlight Harness, VHD" page 119
	Headlight Harness, VNM	"Headlight Harness, VNM" page 120
	Headlight Harness, VNL	"Headlight Harness, VNL" page 121
	Fog and Driving Lights, VHD Harness	"Fog and Driving Lights, VHD" page 122
	Fog and Driving Lights, VNL and VNM Harness	"Fog and Driving Lights, VNL and VNM" page 123
	Tail Lights Harness	"Tail lights" page 124
Engine Compartment		
	Alternator	"Alternator (typical view)" page 125
	Engine, Volvo D12D	"D12D" page 126
	Engine, Cummins ISX	"Engine, Cummins ISX" page 128

Number	Description	Page
Transmission		
	Allison HD Transmission, VHD (BBOX-LF)	"Allison HD Transmission, VHD (BBOX-LF)" page 129
	Allison HD Transmission, VHD (BBOX-LB/BBOX-RF)	"Allison HD Transmission, VHD (BBOX-LB/BBOX-RF)" page 130
	Allison MD Transmission, VHD (BBOX-LF)	"Allison MD Transmission, VHD (BBOX-LF)" page 131
	Allison MD Transmission, VHD (BBOX-LB/BBOX-RF)	"Allison MD Transmission, VHD (BBOX-LB/BBOX-RF)" page 132
	Eaton Autoshift II Transmission	"Eaton Autoshift II Transmission" page 133
	Meritor Lightning Transmission	"Meritor Lightning Transmission" page 134
	Meritor Transmission	"Meritor Transmission" page 135
	Fuller Transmission	"Fuller Transmission" page 136
Chassis		
	Washer Reservoir	"Washer Reservoir, VN" page 137
	Washer Fill	"Washer Reservoir, VHD" page 138
	Horn	"Horn" page 139
	Fuel Sensor	"Fuel Level Sensor" page 140
	Diff Lock / Axle Temperature Harness	"Differential Lock/Axle Temperature" page 141
	Central Tire Inflation ECU	"Central Tire Inflation System" page 142
	Ambient Temperature Sensor	"Ambient Temperature Sensor" page 143
	Pyrometer Sensor	"Pyrometer Sensor" page 144
	Chassis Harness	"Chassis Harness" page 145
	VORAD Antennas	"VORAD Antennas" page 146
	Inverter Harness	"Inverter" page 147
	Bobybuilder Box	"Bodybuilder Box, VHD" page 118

Fuse and Relay Center, Main Cab Harness (including Bodybuilder Module)

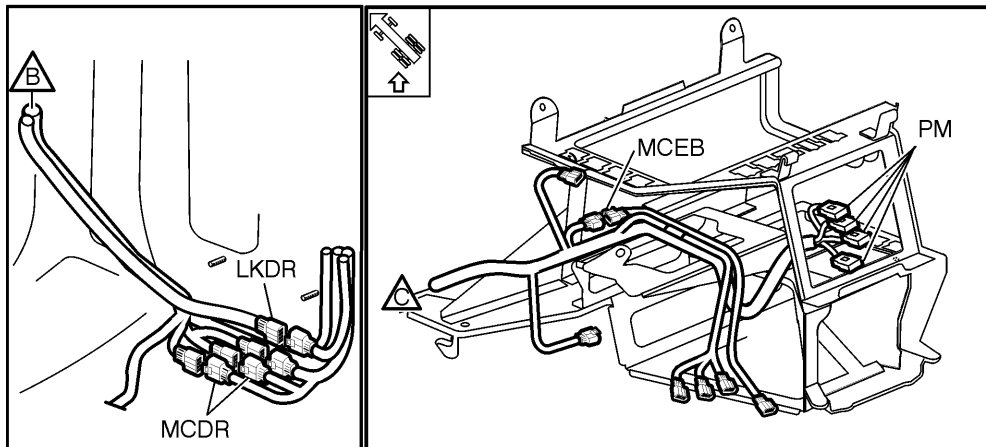
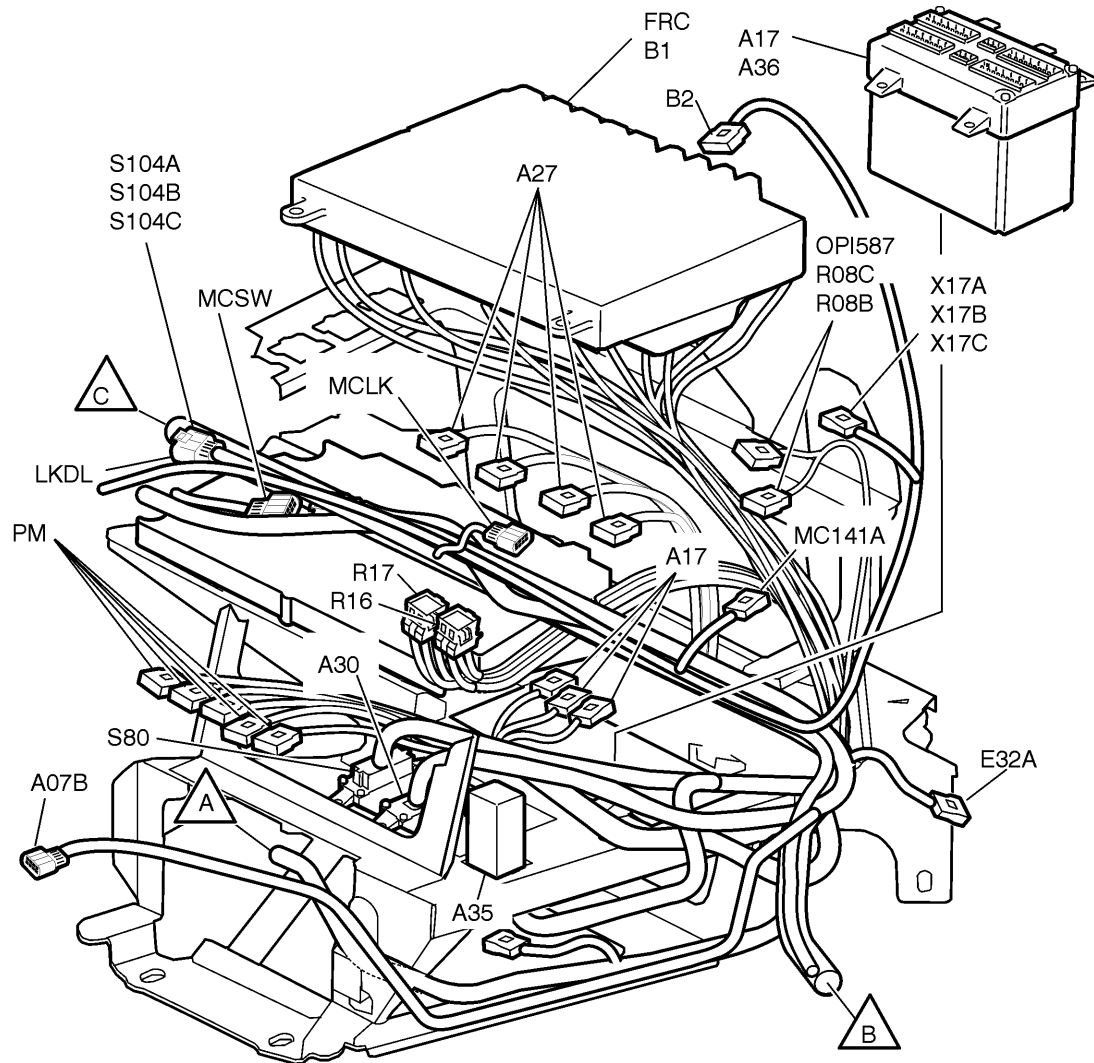

W3005945

Cab Wiring Passthrough

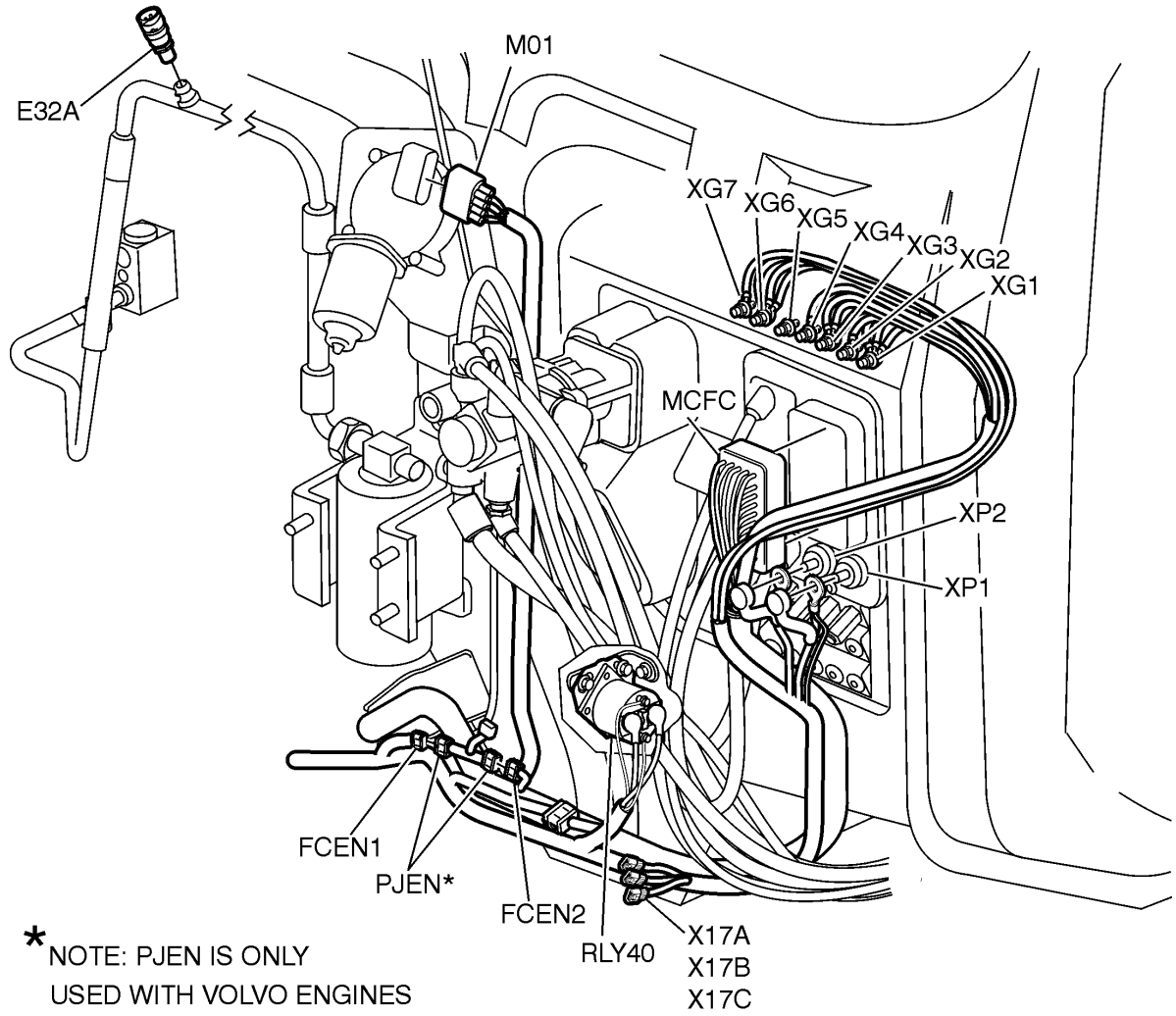

* NOTE: PJEN IS ONLY
USED WITH VOLVO ENGINES

W3006512



Dash Switches, VHD

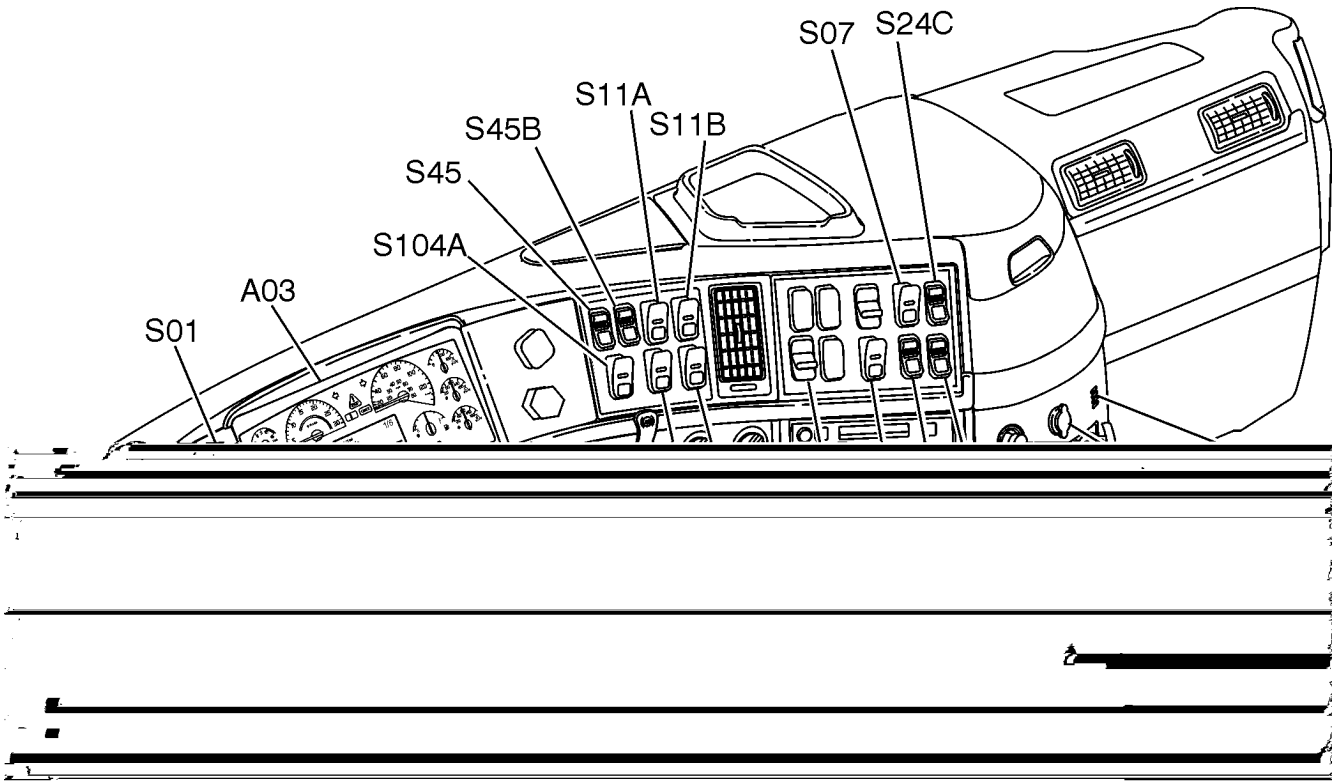

W3006514

Dash Harness and Cab Wiring Passthrough

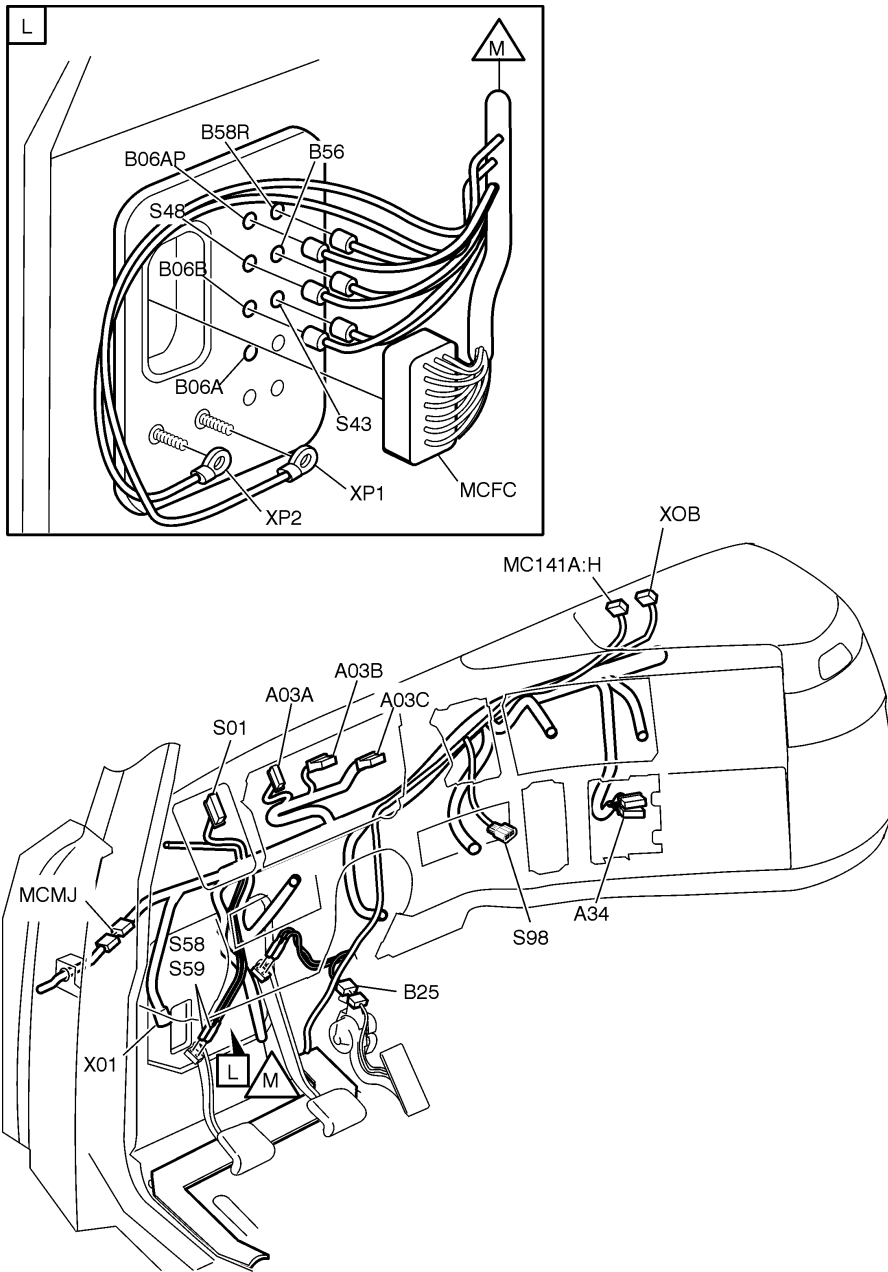

W3005946

Dash Harness, Road Relay

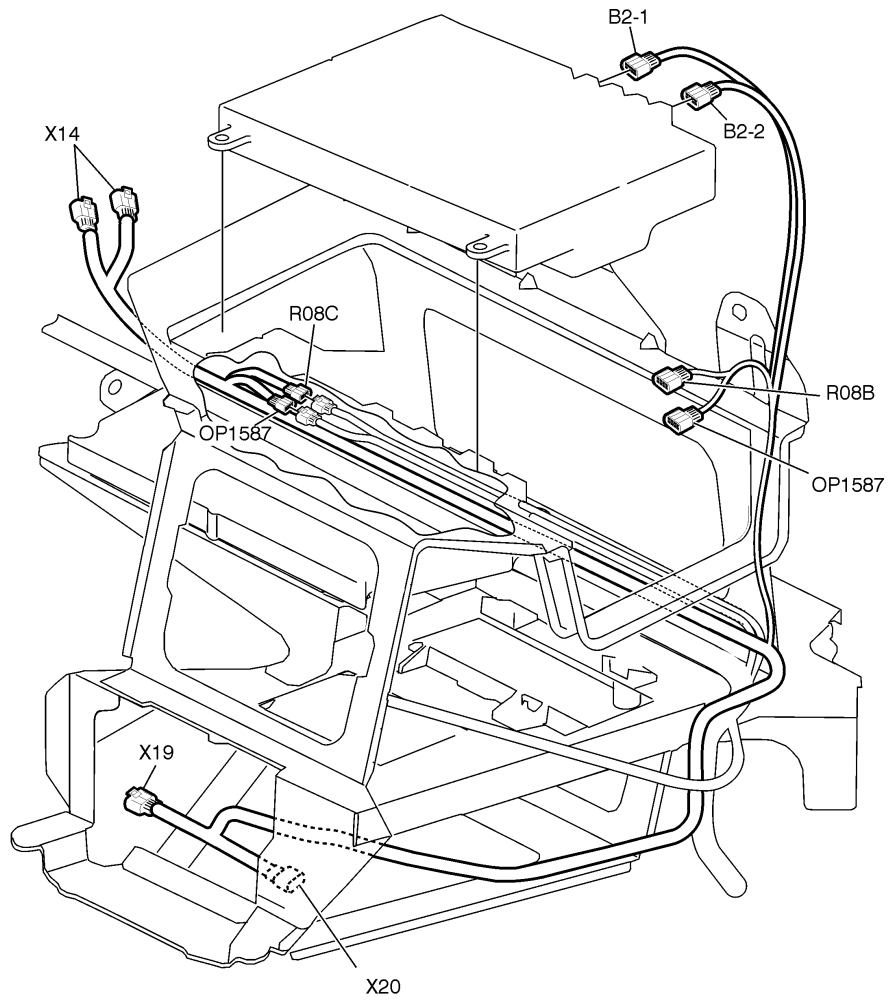

W3005947

Dash Harness, Qualcomm

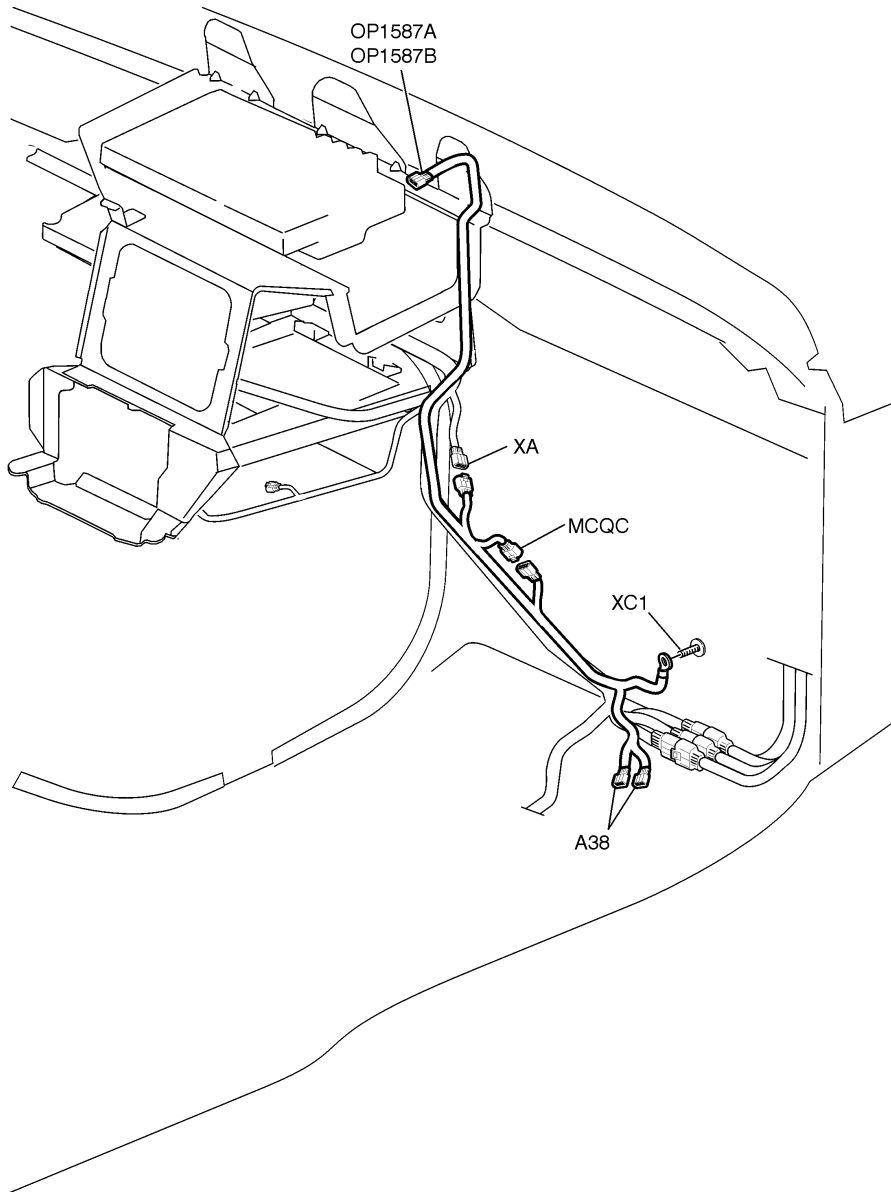

W3005948

Dash Harness, Snow Plow/ Beacon Lights Option

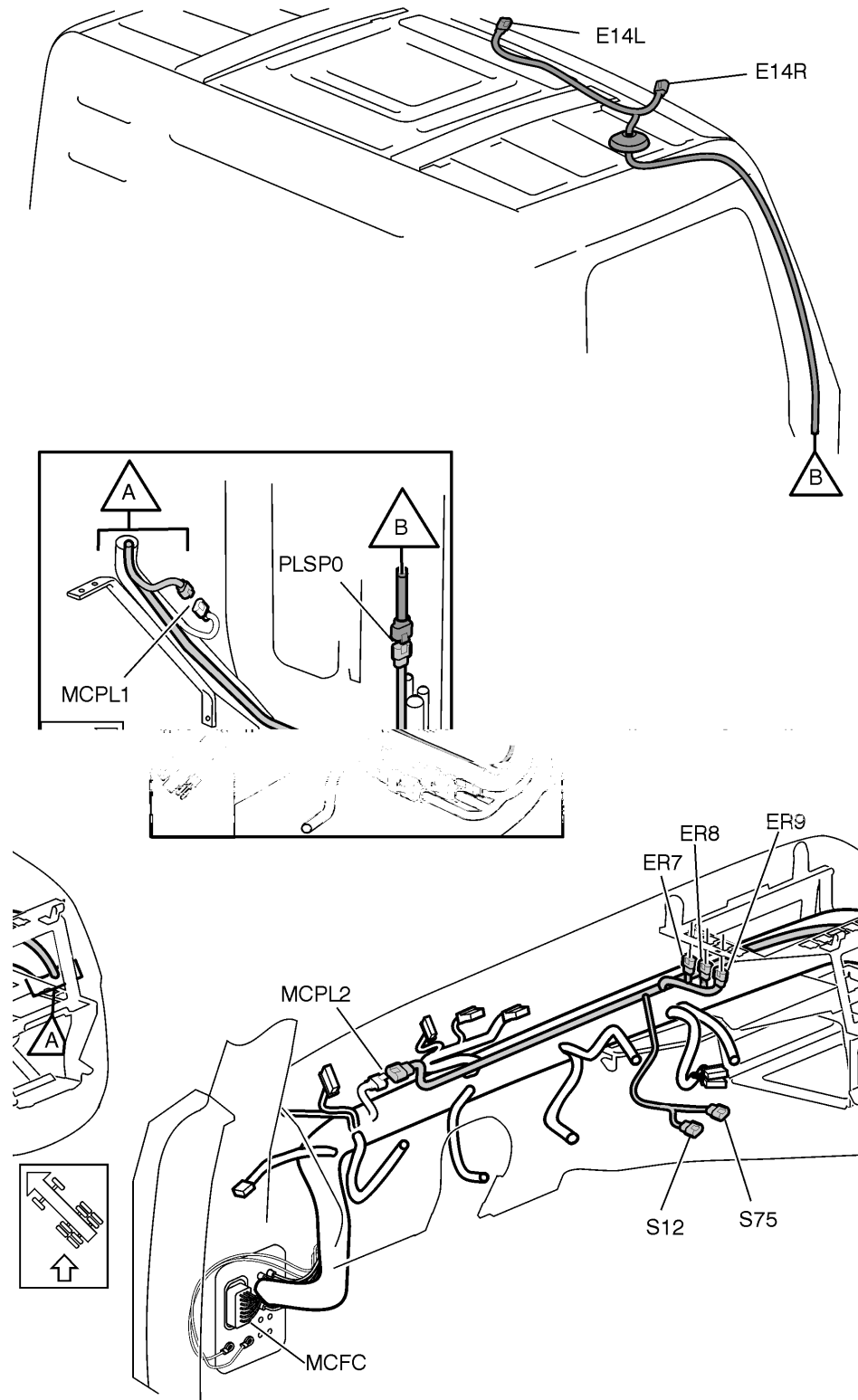

W3006379

Front Overhead Shelf/CB Power Harness

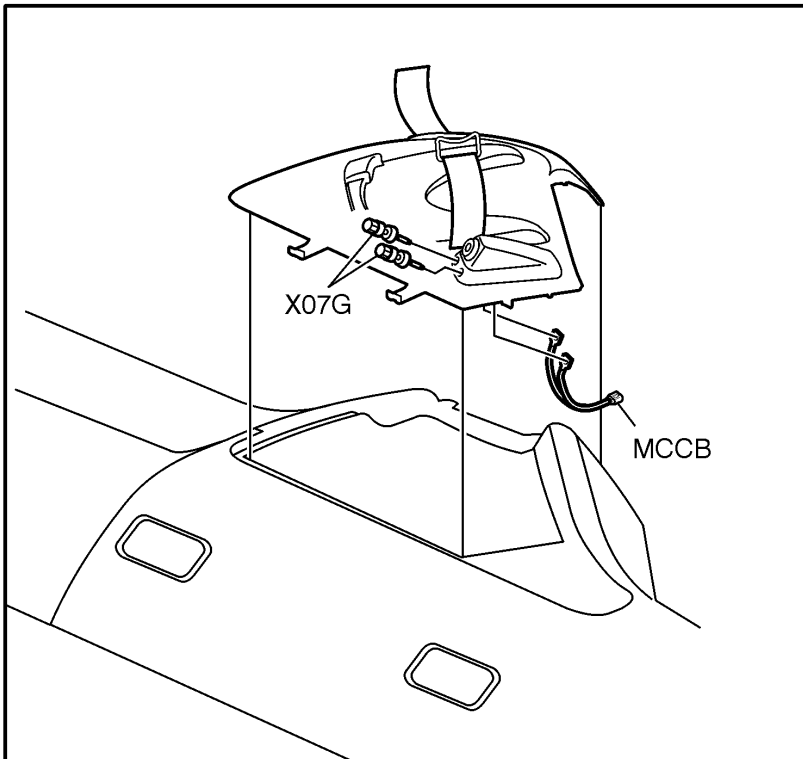
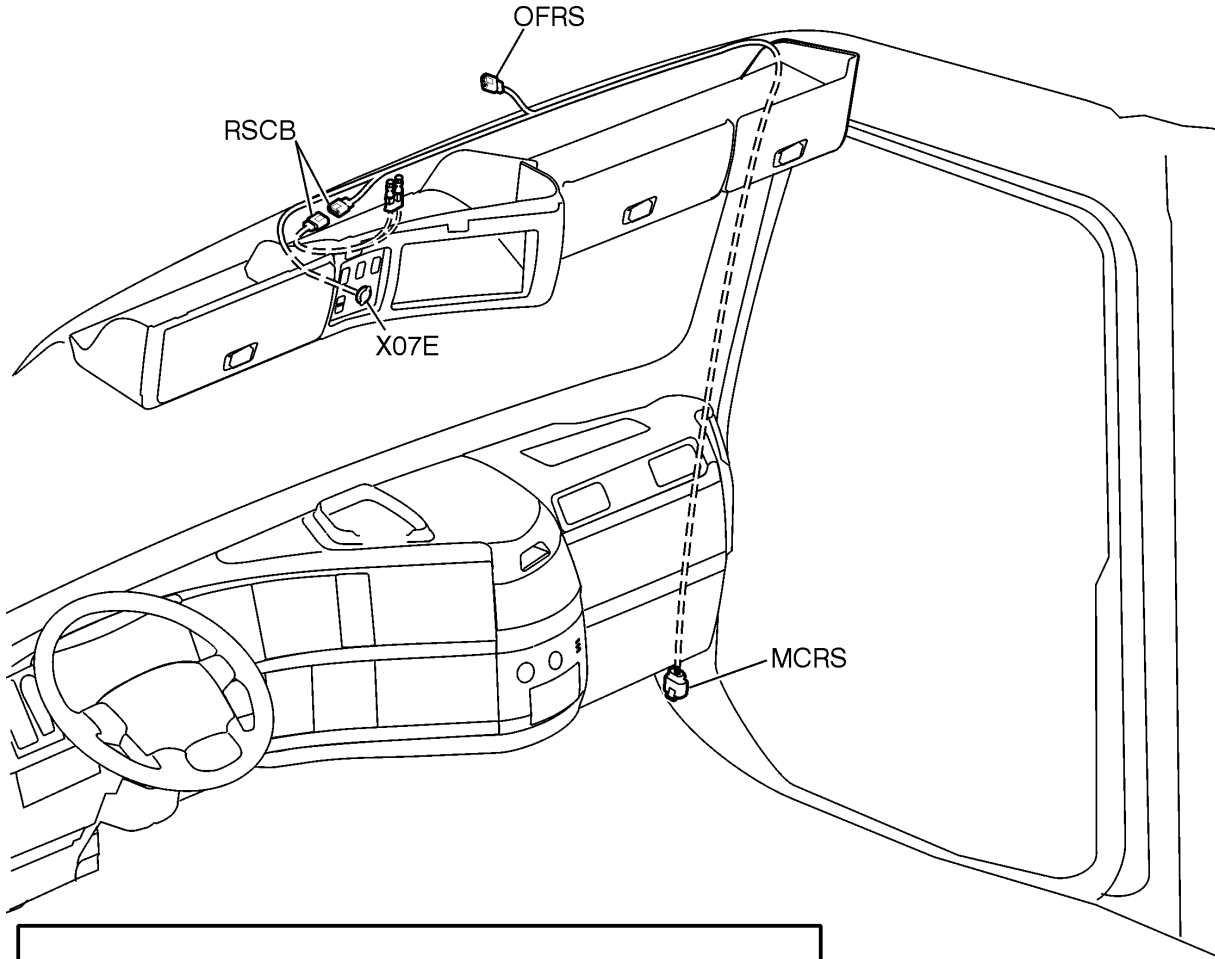

W3005899

Radio Harness

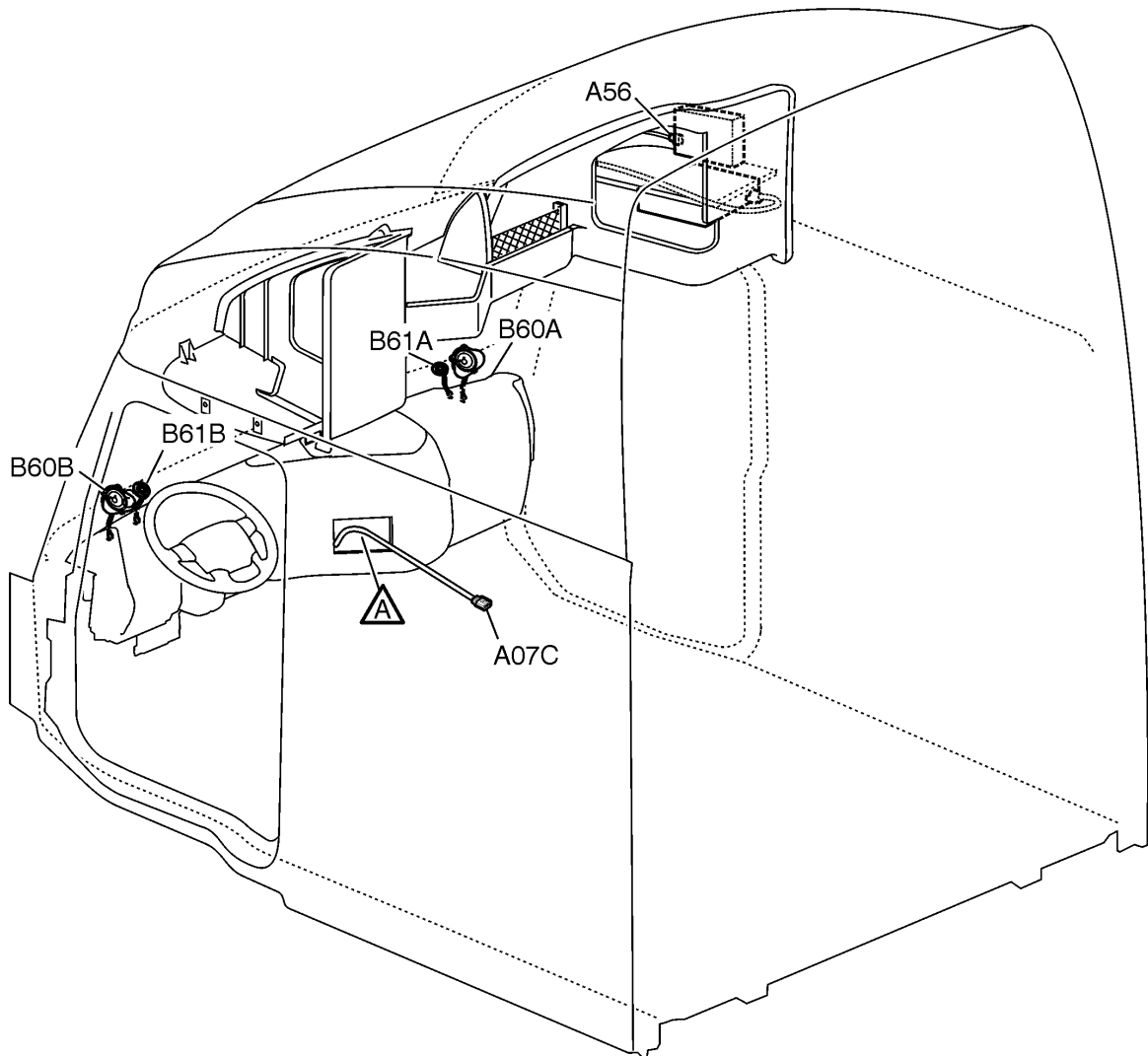
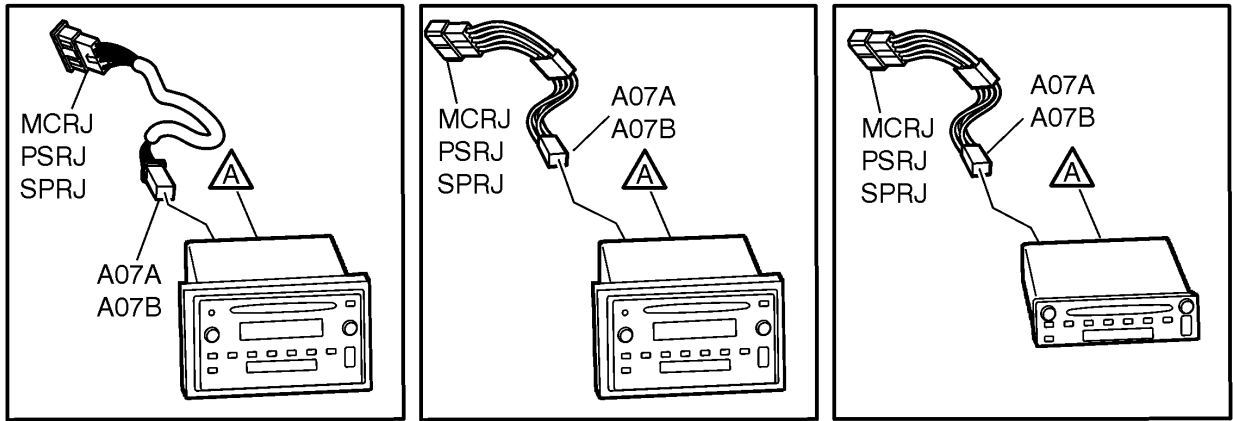

Steering Column Harness, Including Stalk Switches

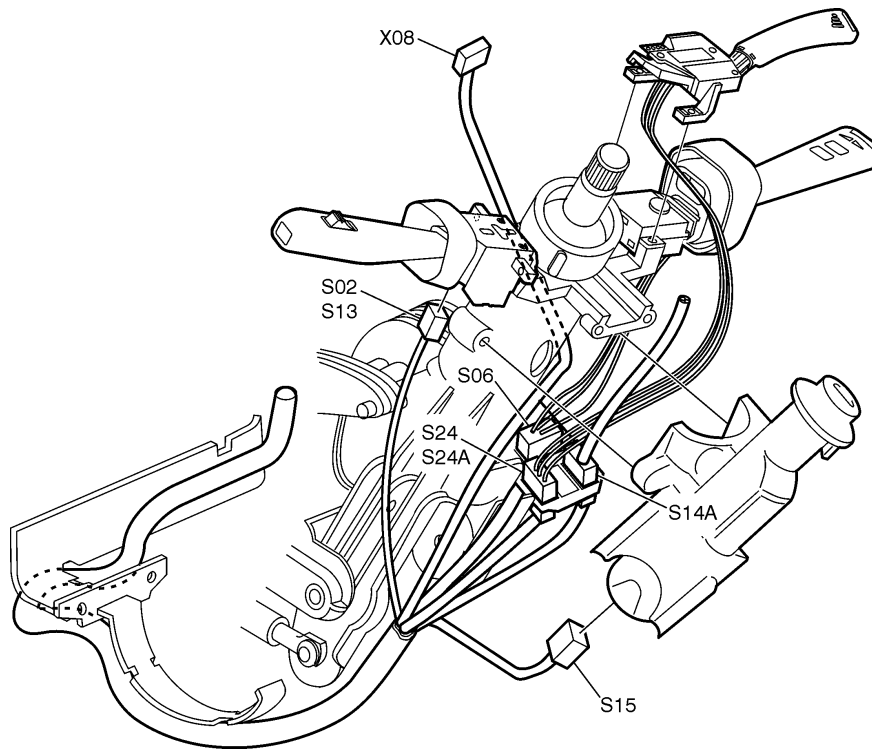

W3005949

Cab Floor Harnesses, Front

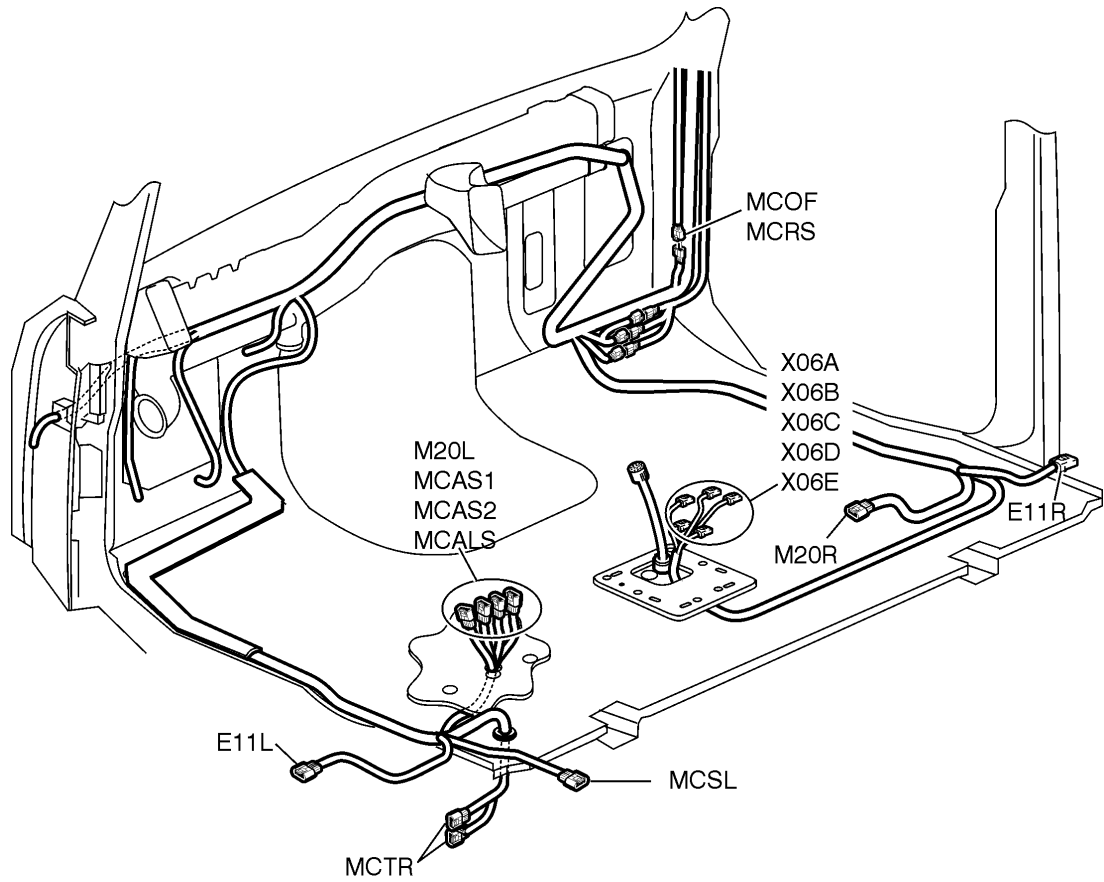

W3005950

Cab Floor Harness, Bodybuilder Option (VHD)

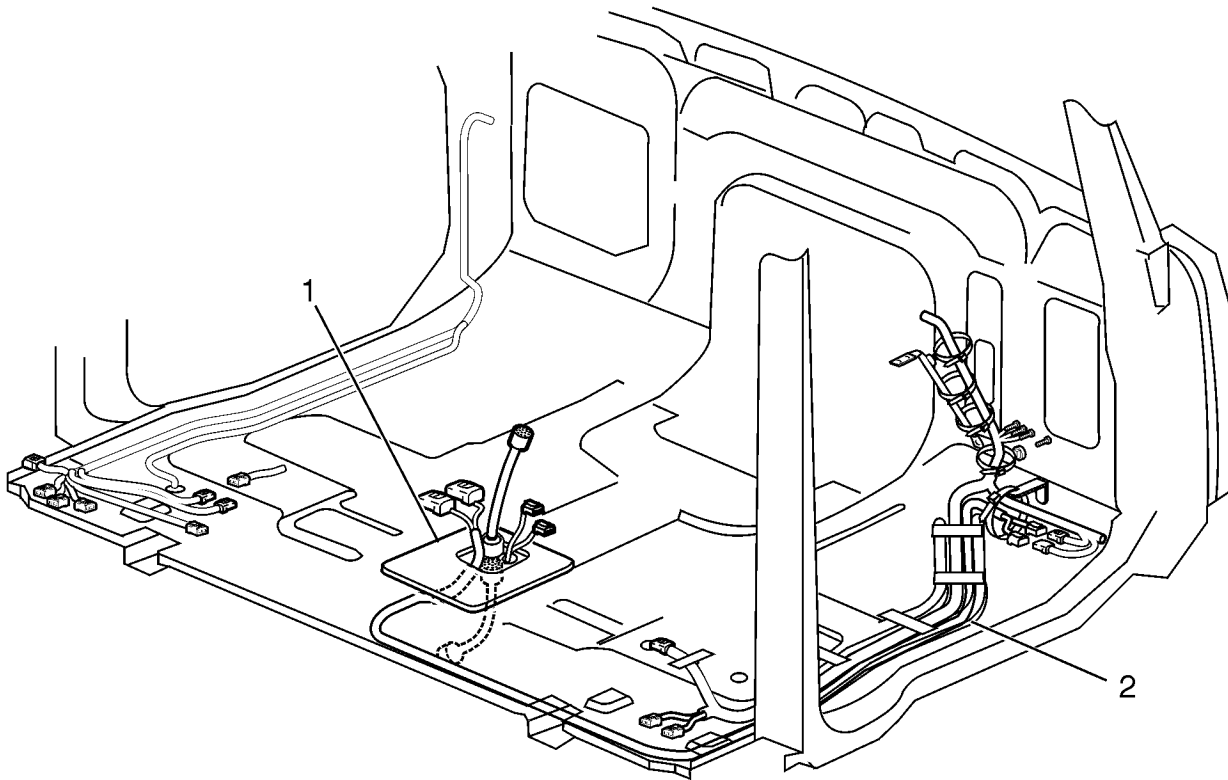

- 1 Bodybuilder Cab Floor Passthrough Harness
- 2 Bodybuilder Overlay Harness (either 2 or 4 connectors on each side)

W3006394

Rear Cab Harness, VN430

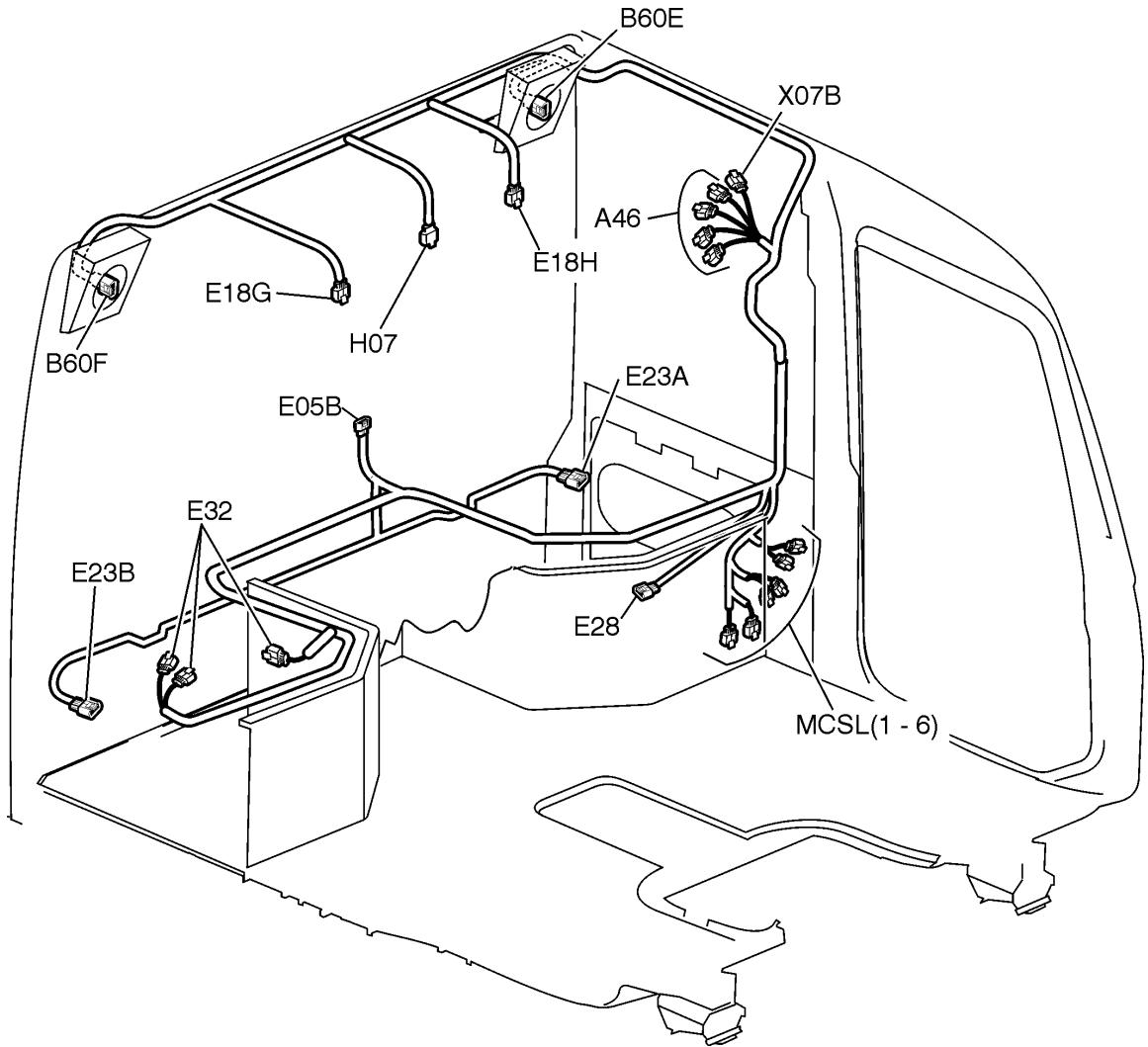

W3005902

Rear Cab Harness, VN630

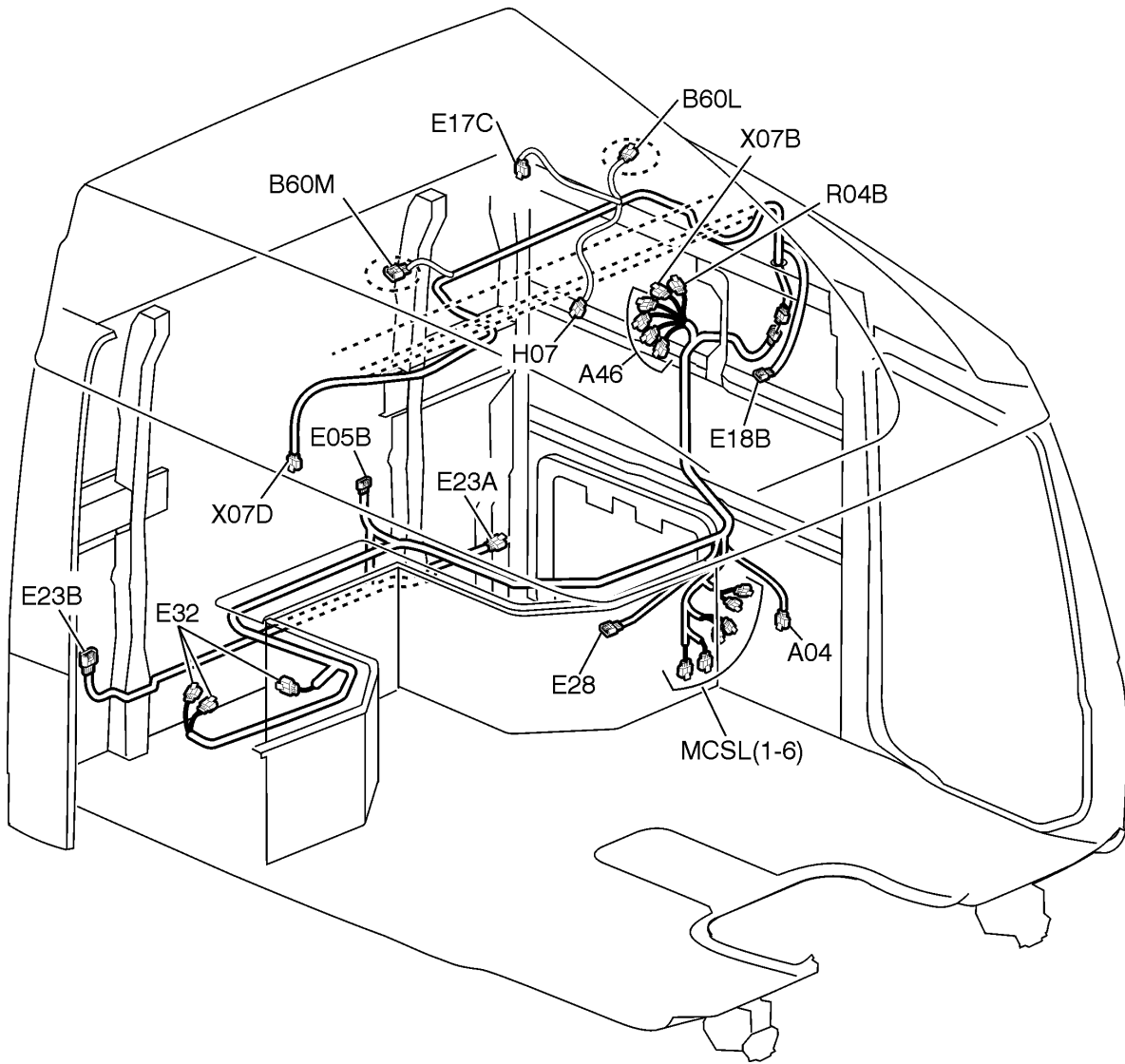

W3005896

Rear Cab Harness, VN670

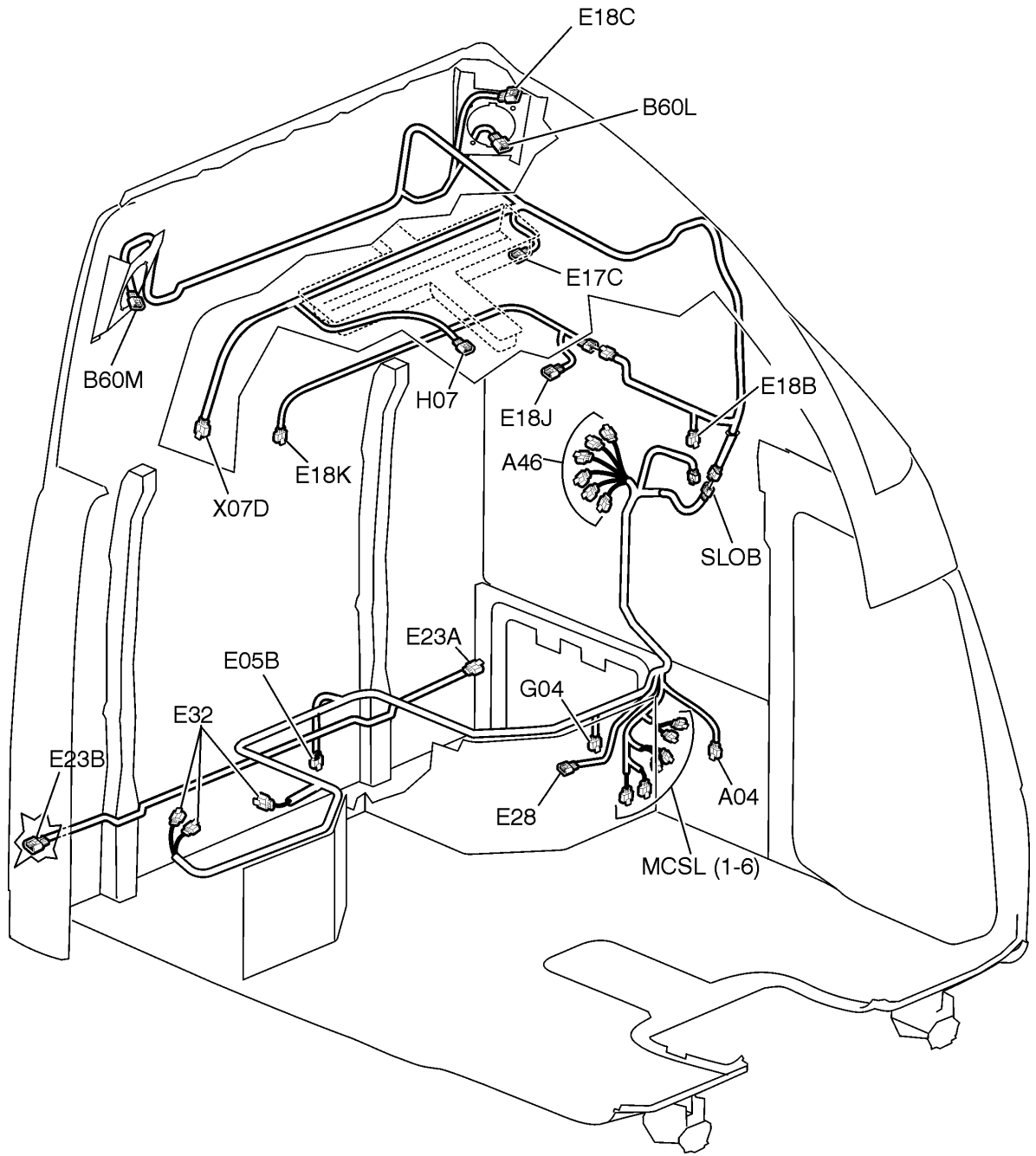

W3005887

Rear Cab Harness, VN780

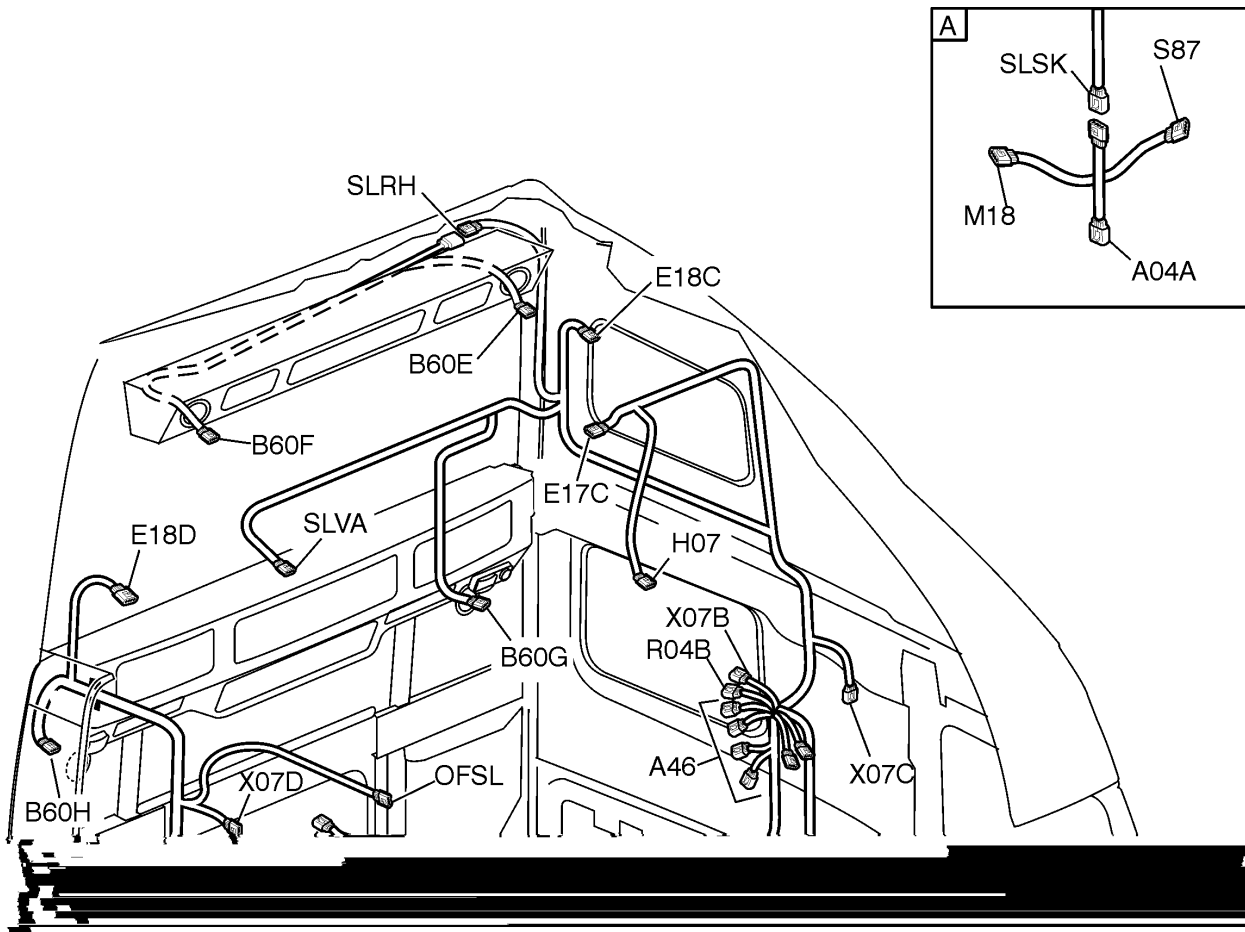

W3005889

Rear Cab, Lower Wall Harness, VN780

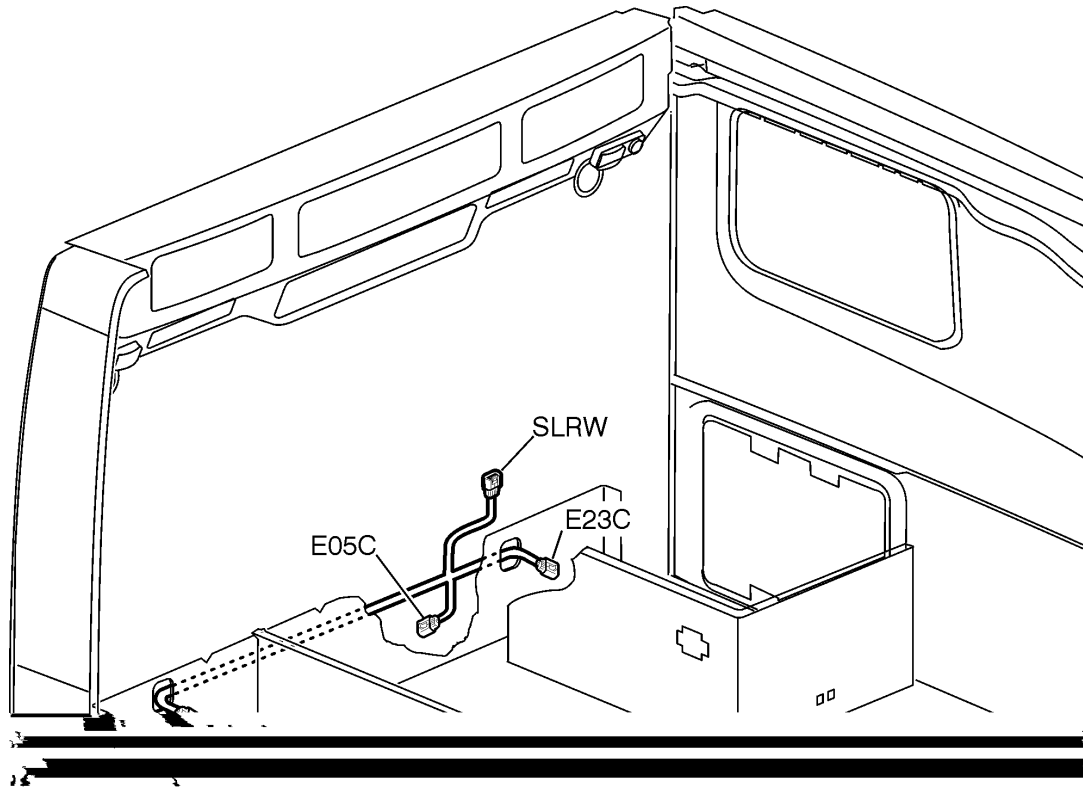

W3005888

Rear Cab Valance Harness, VN780

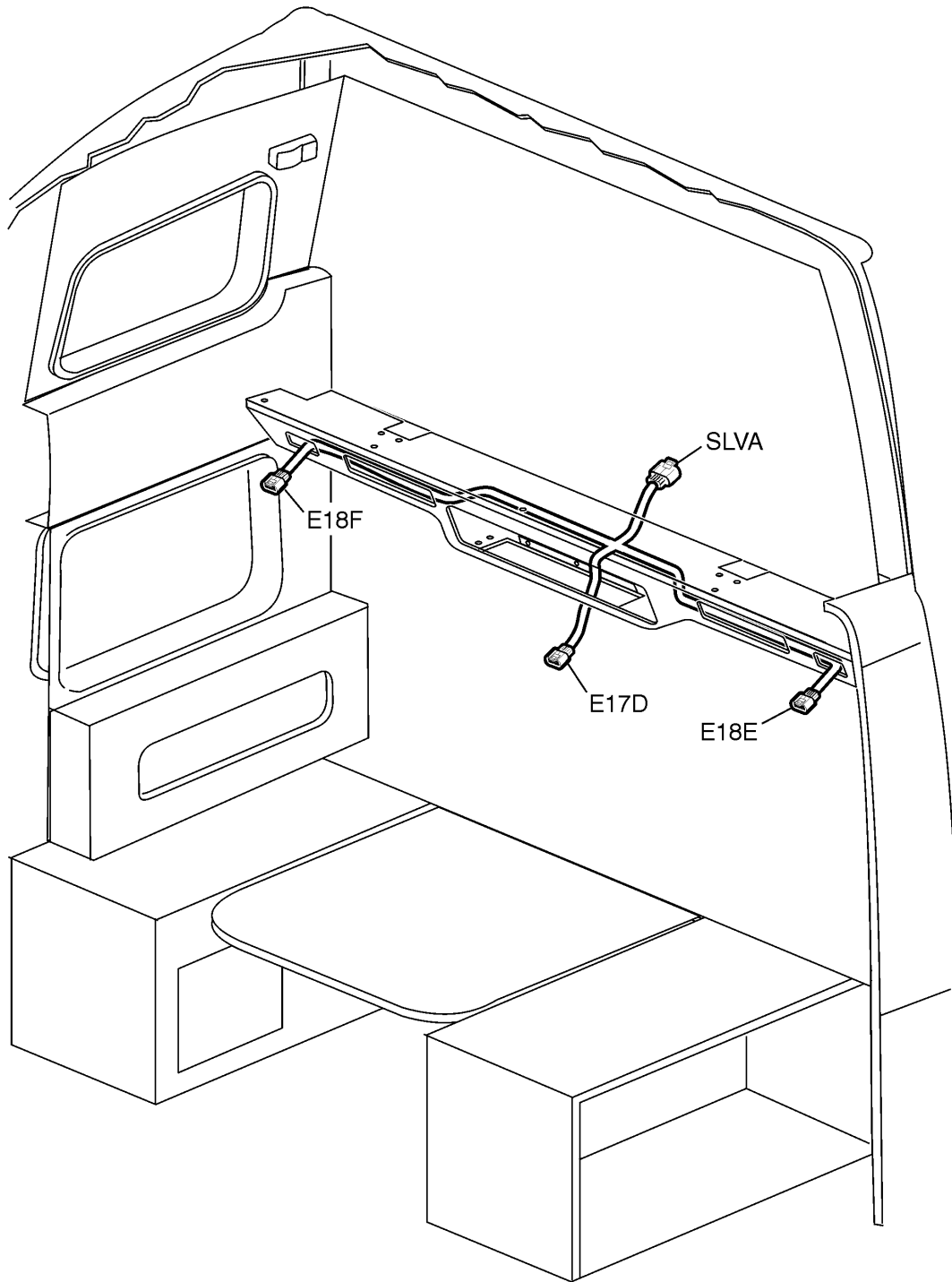

W3005936

Rear Cab Harness, Back of Cab Lights (HDI/HDO Variant)

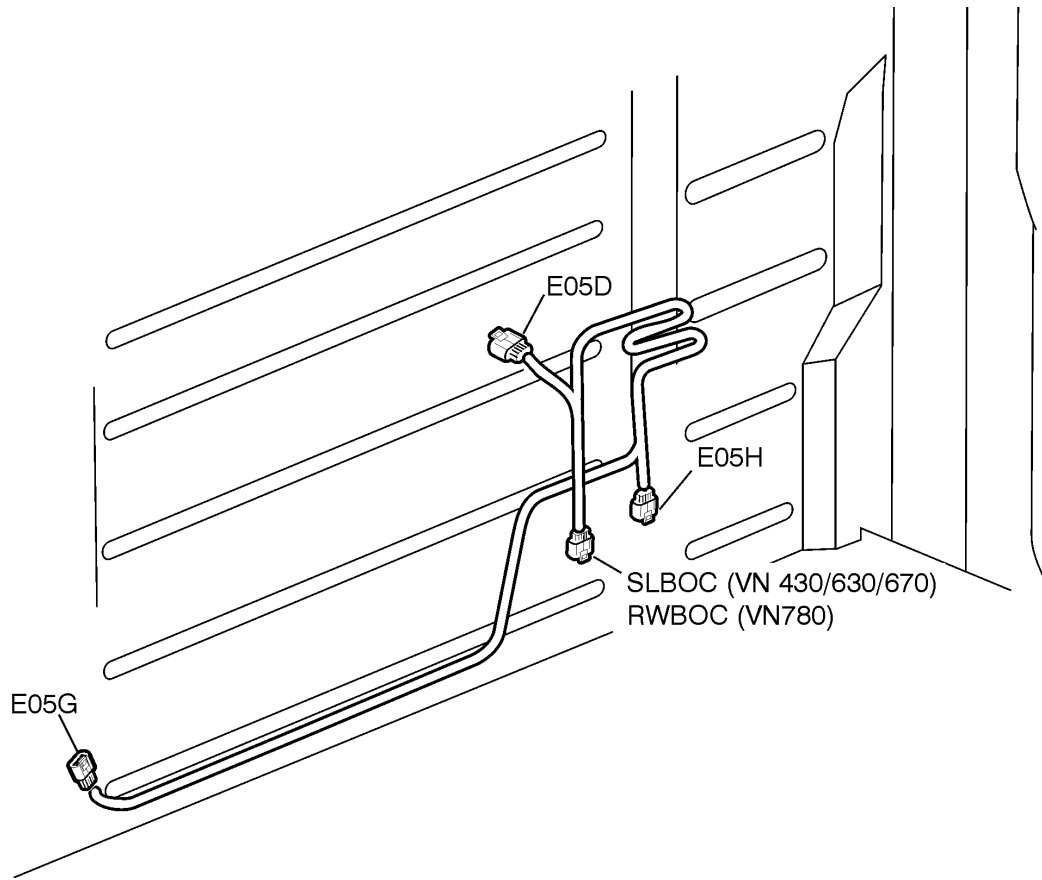

W3005905

Rear Cab Harness, Back of Cab Lights (LDI/LDO Variant)

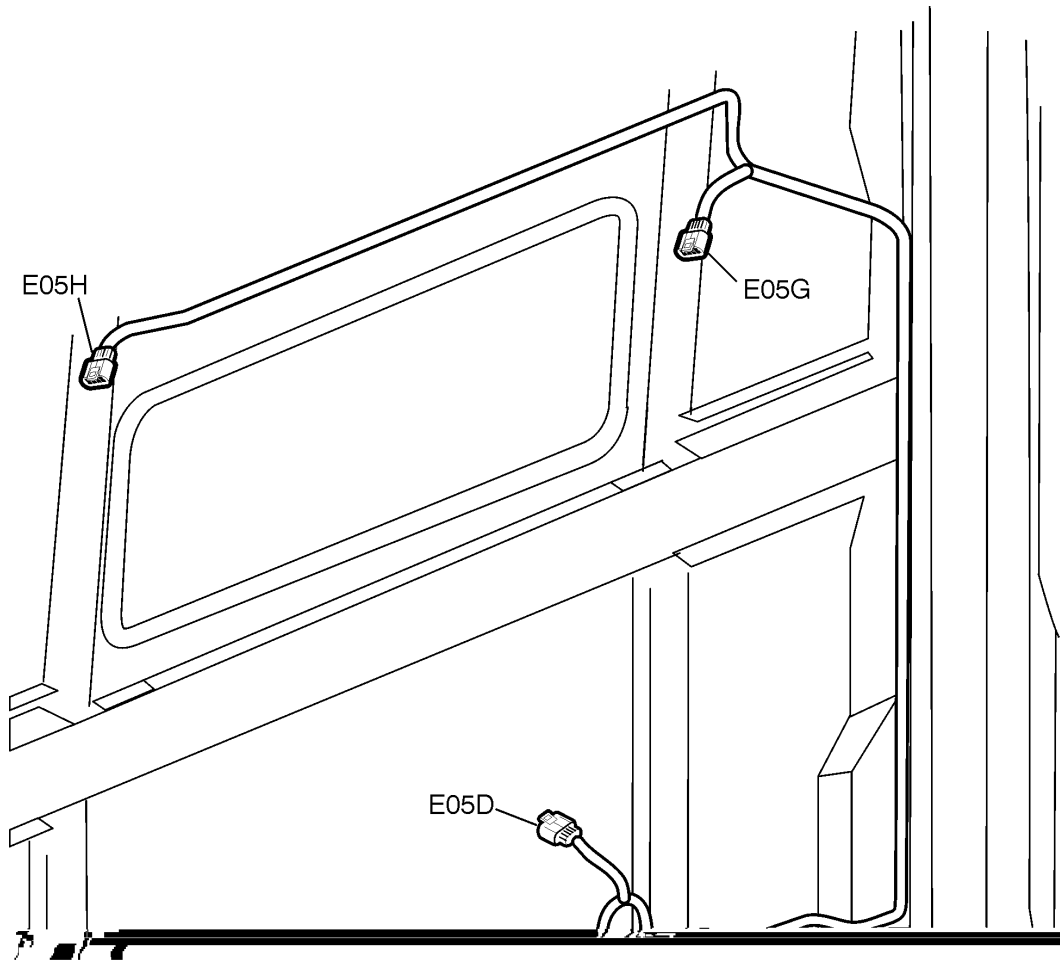

W3005903

Rear Cab Harness, Fifth Wheel Light

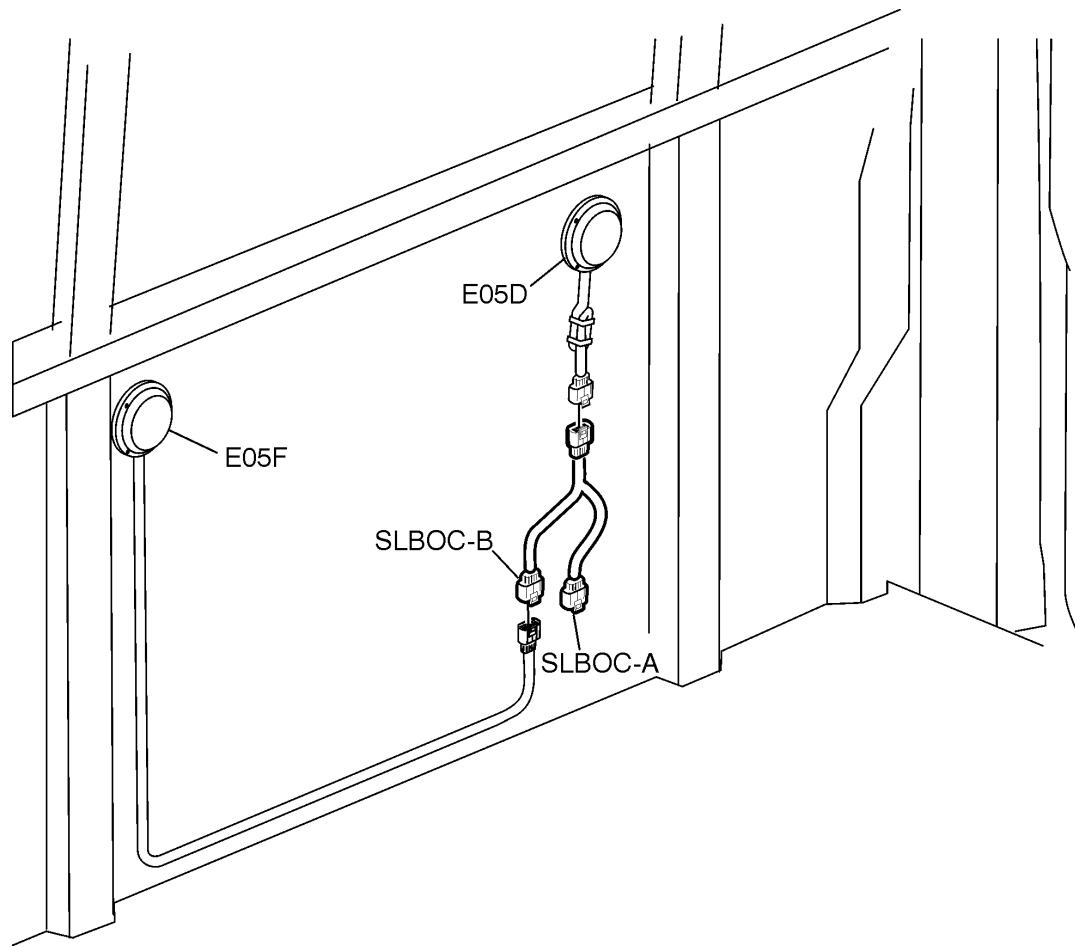

W3005906

Rear Cab Harness, Fifth Wheel Light

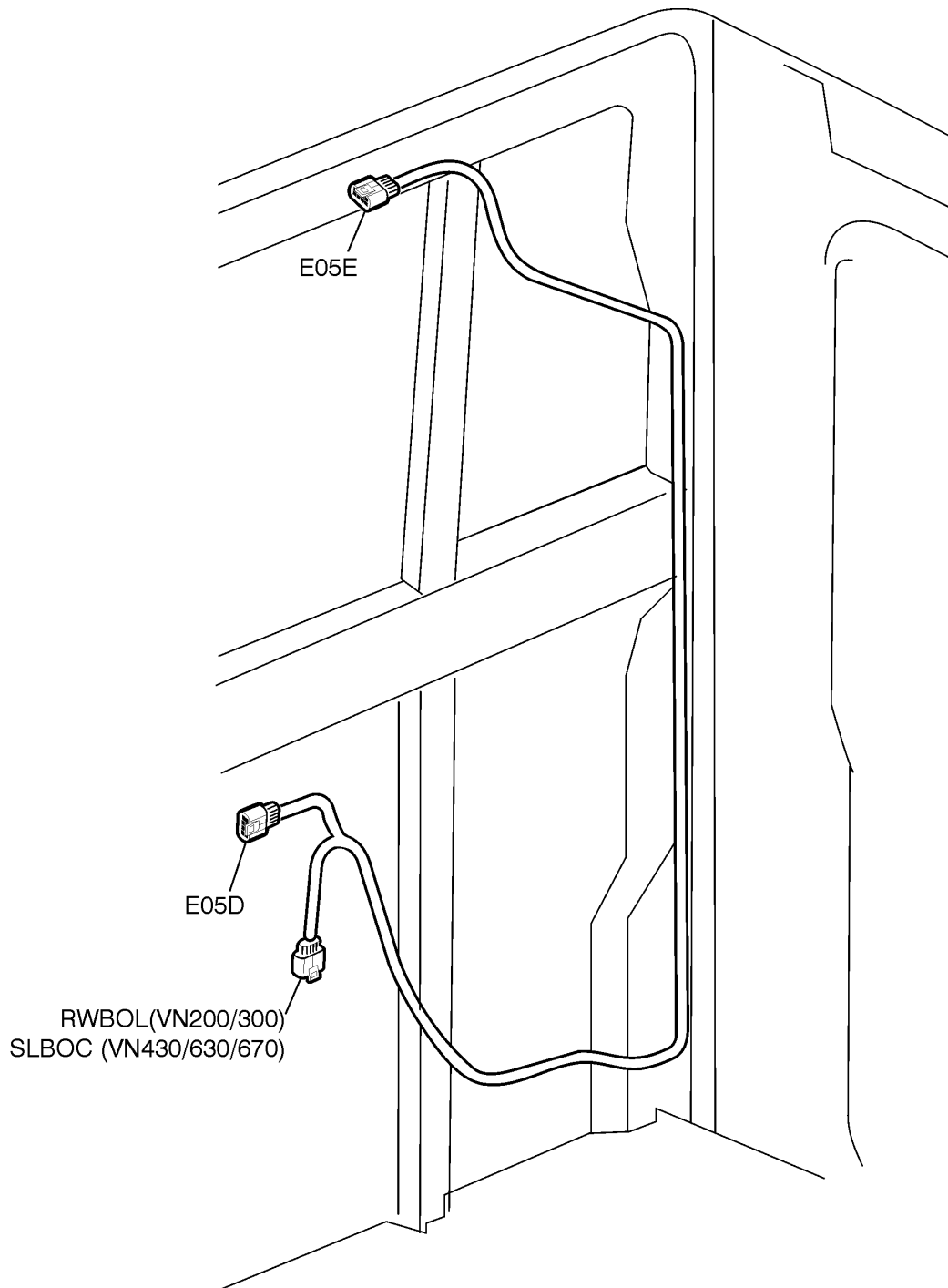

W3005904

Rear Cab Harness, Fifth Wheel Light and Rear Speakers (Daycab)

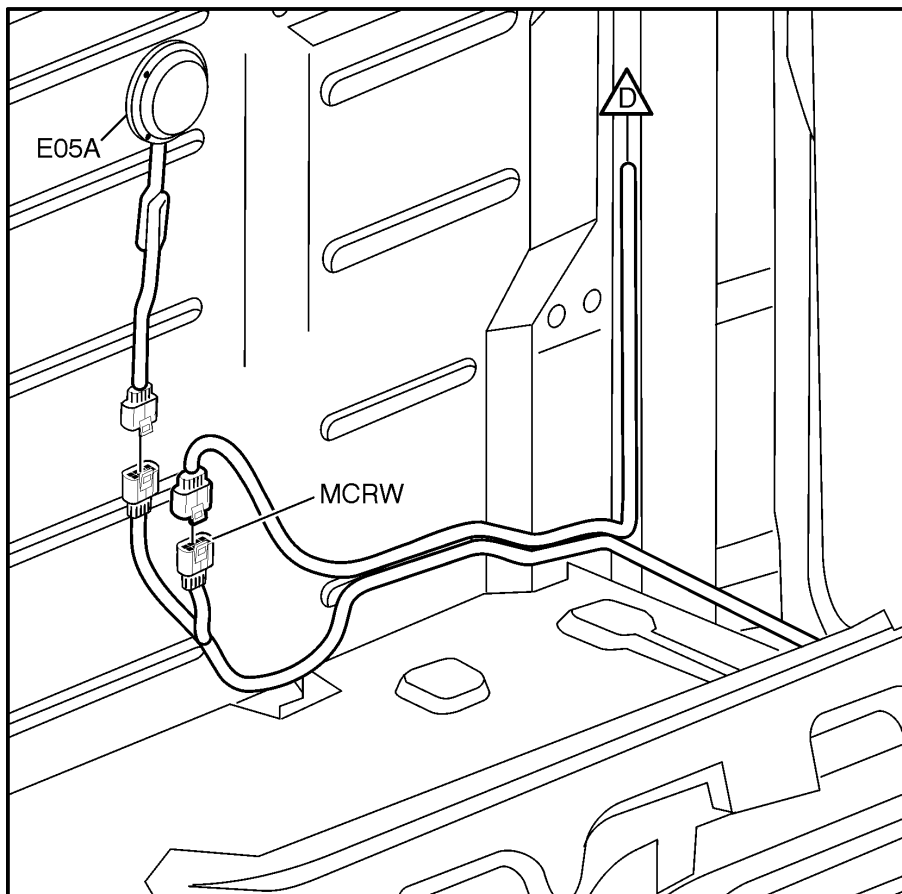
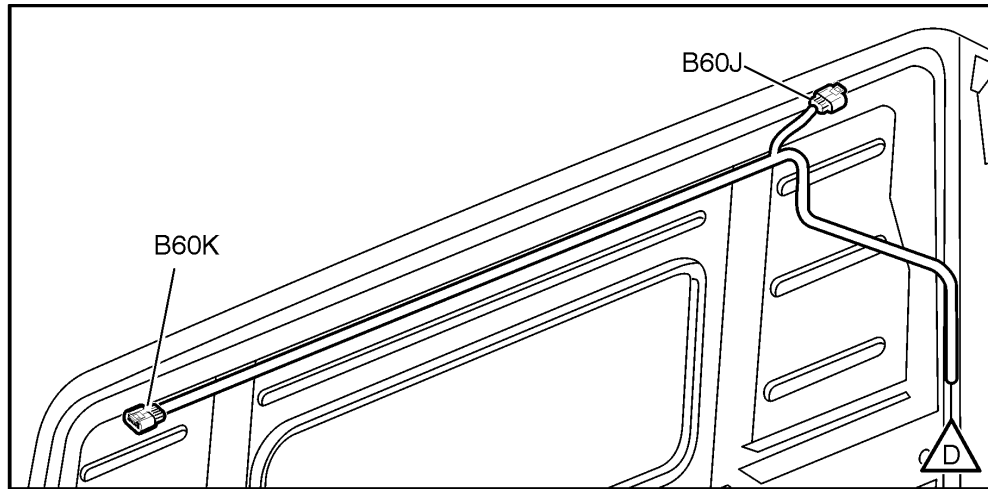

W3005895

Rear Cab Harness, Dual Fifth Wheel Light and Rear Speakers (Daycab)

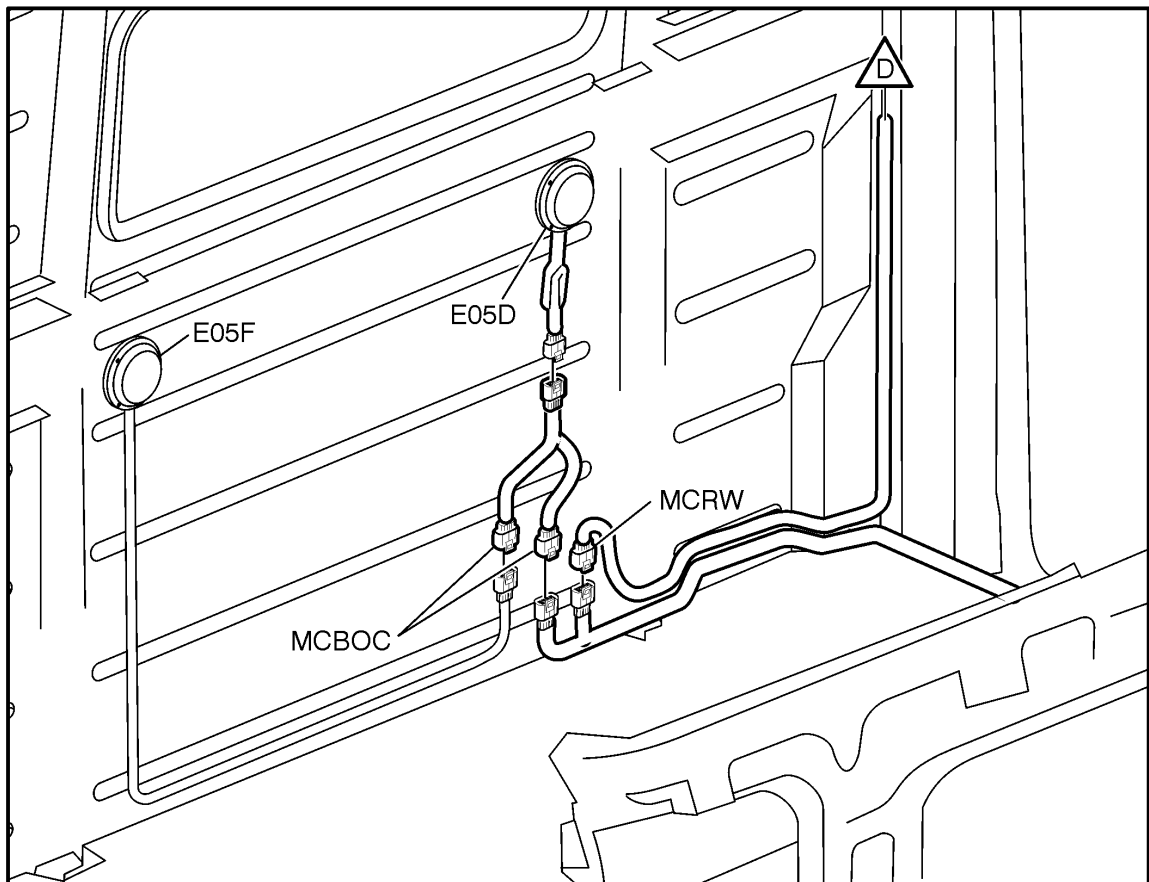
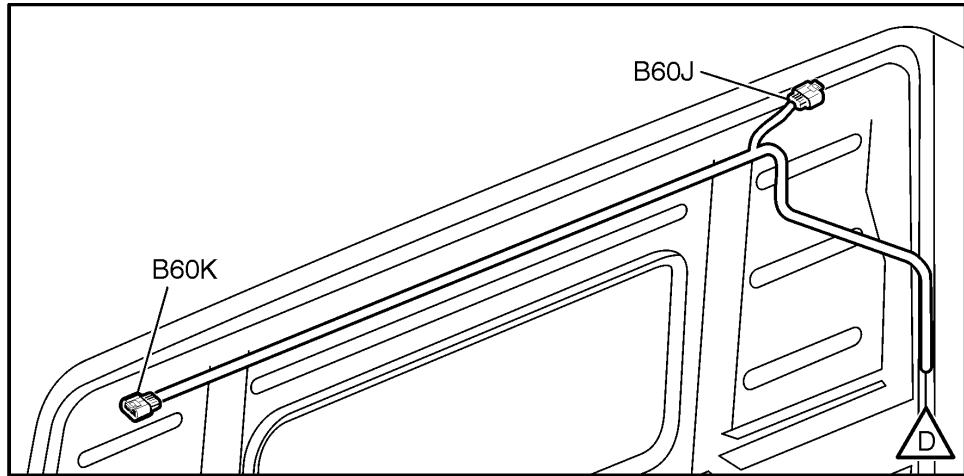

W3005897

Rear Cab Harness, Overhead Lights and Rear Speaker Detail

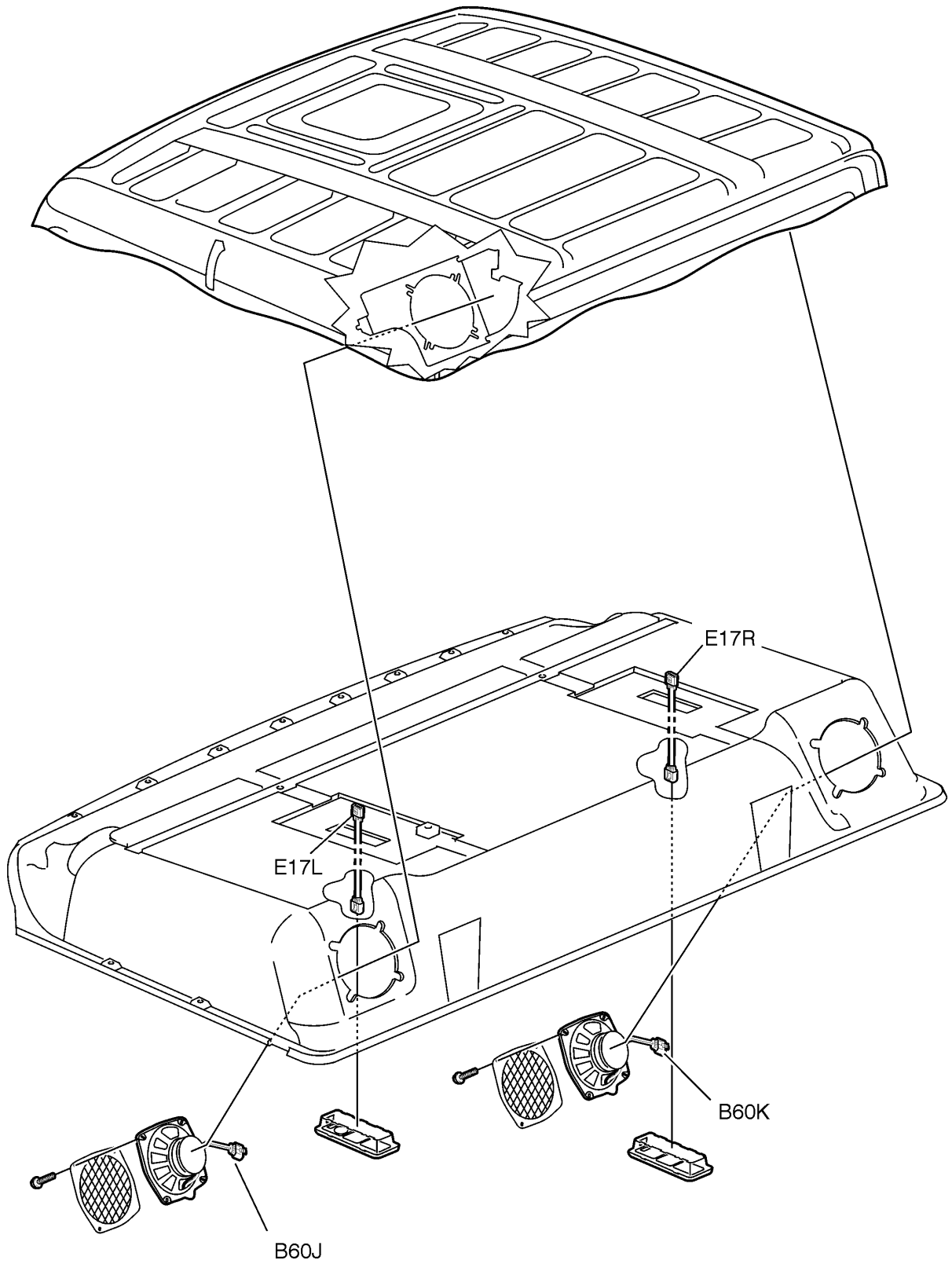

Sleeper Control Panel (LECM)

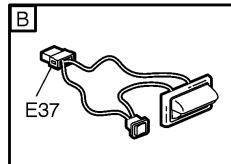
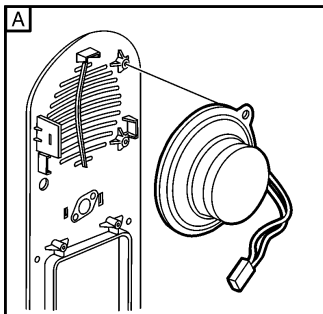
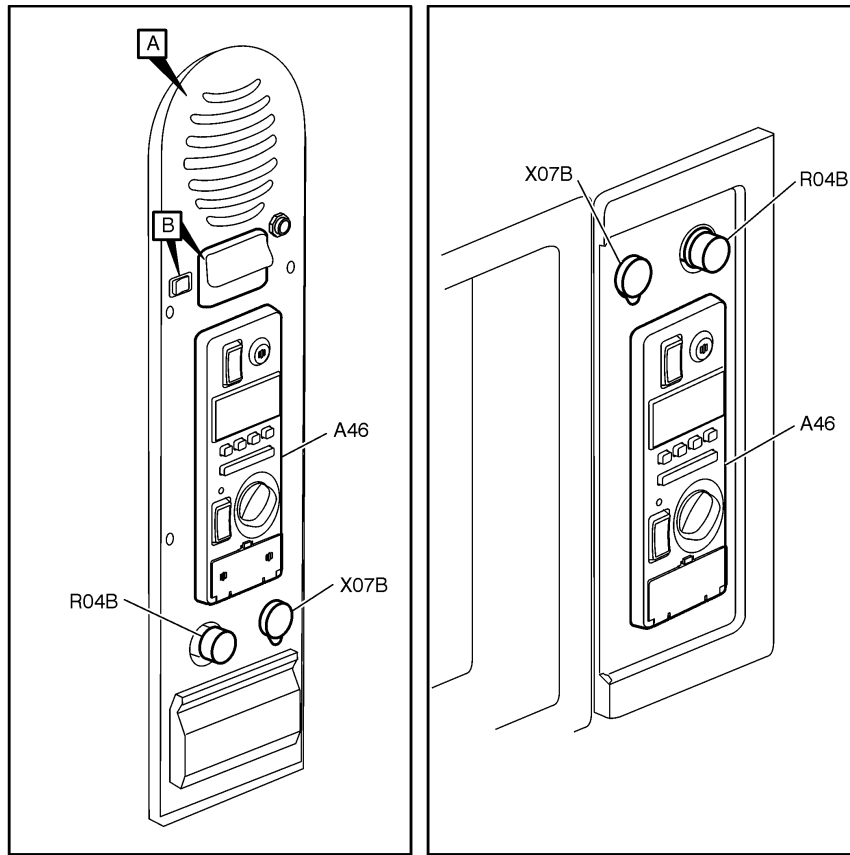

W3005951

Volvo Link Harness and Antennas

Volvo Link Harness and Antennas, Day Cab

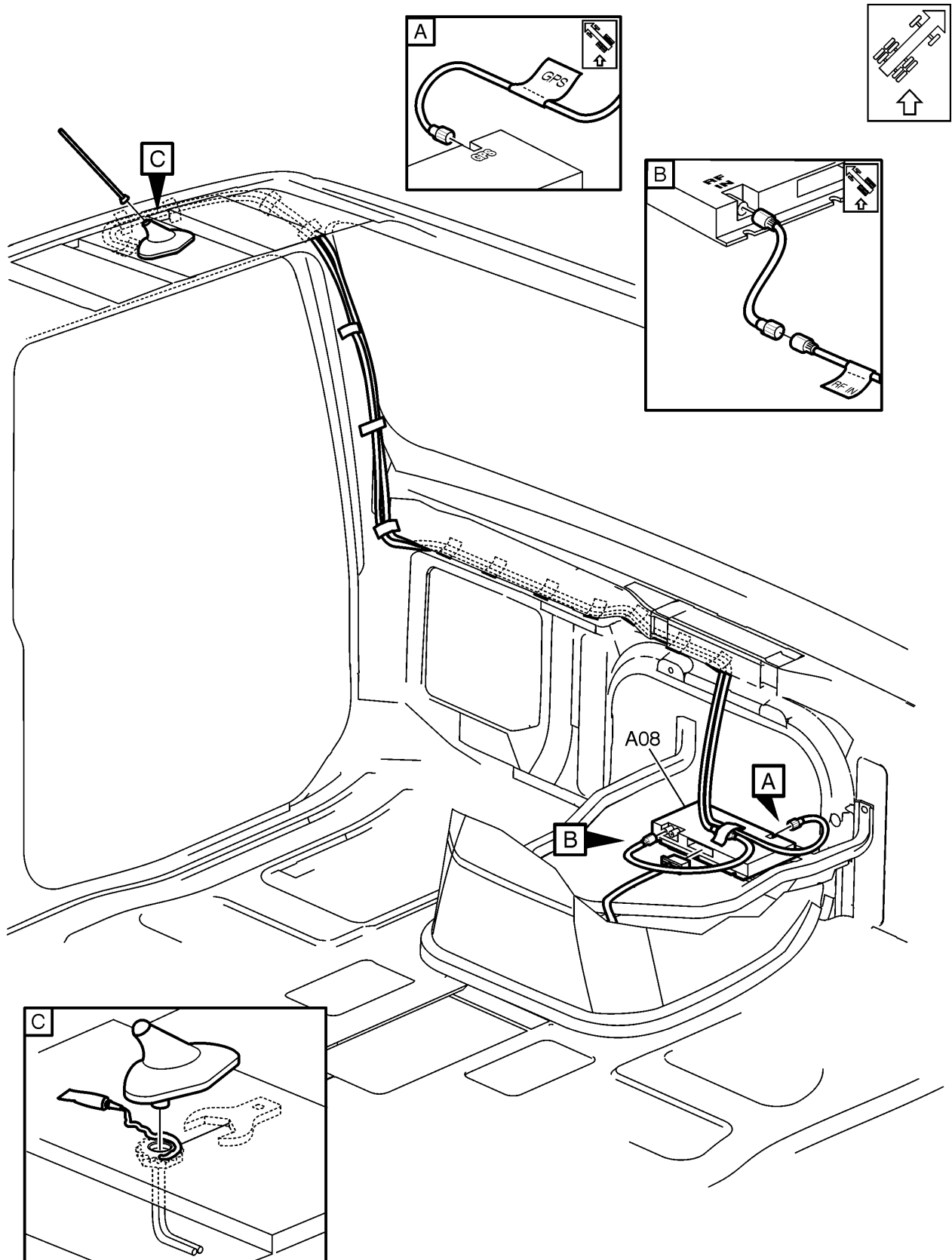

Volvo Link Harness and Antennas, 630 Sleeper Cab

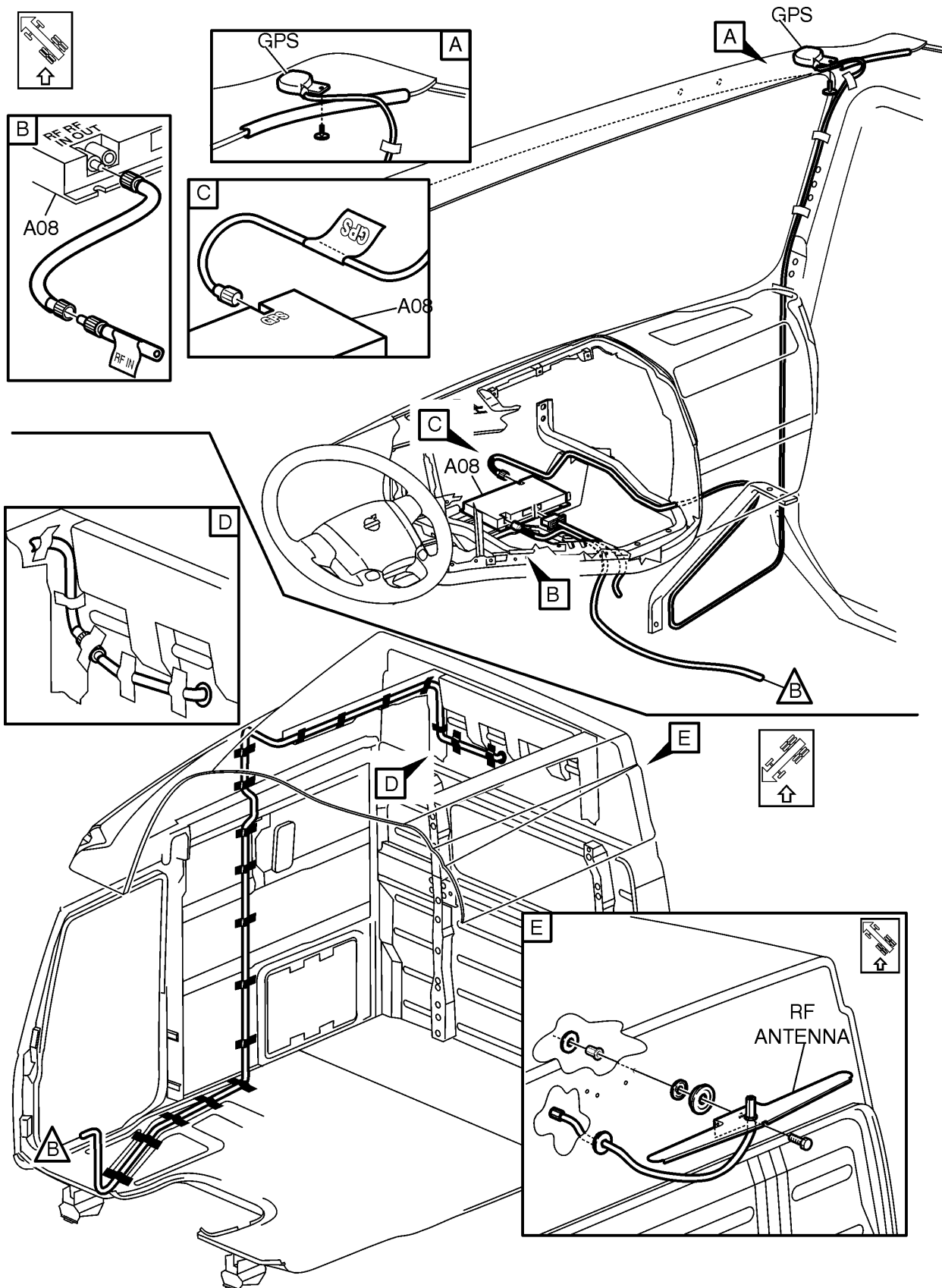

W3006396

Volvo Link Harness and Antennas, 670/780 Sleeper Cab

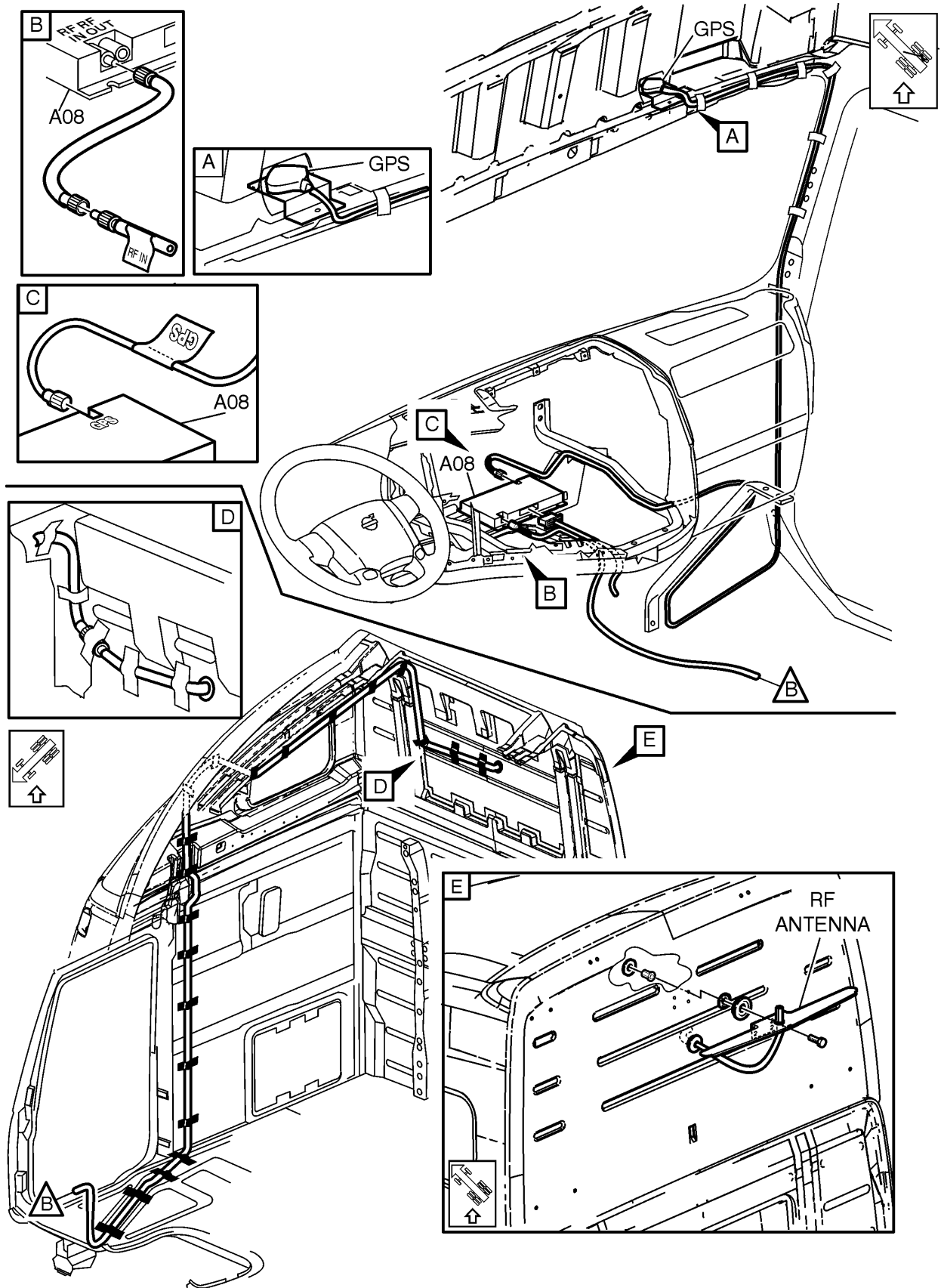

Door Harness

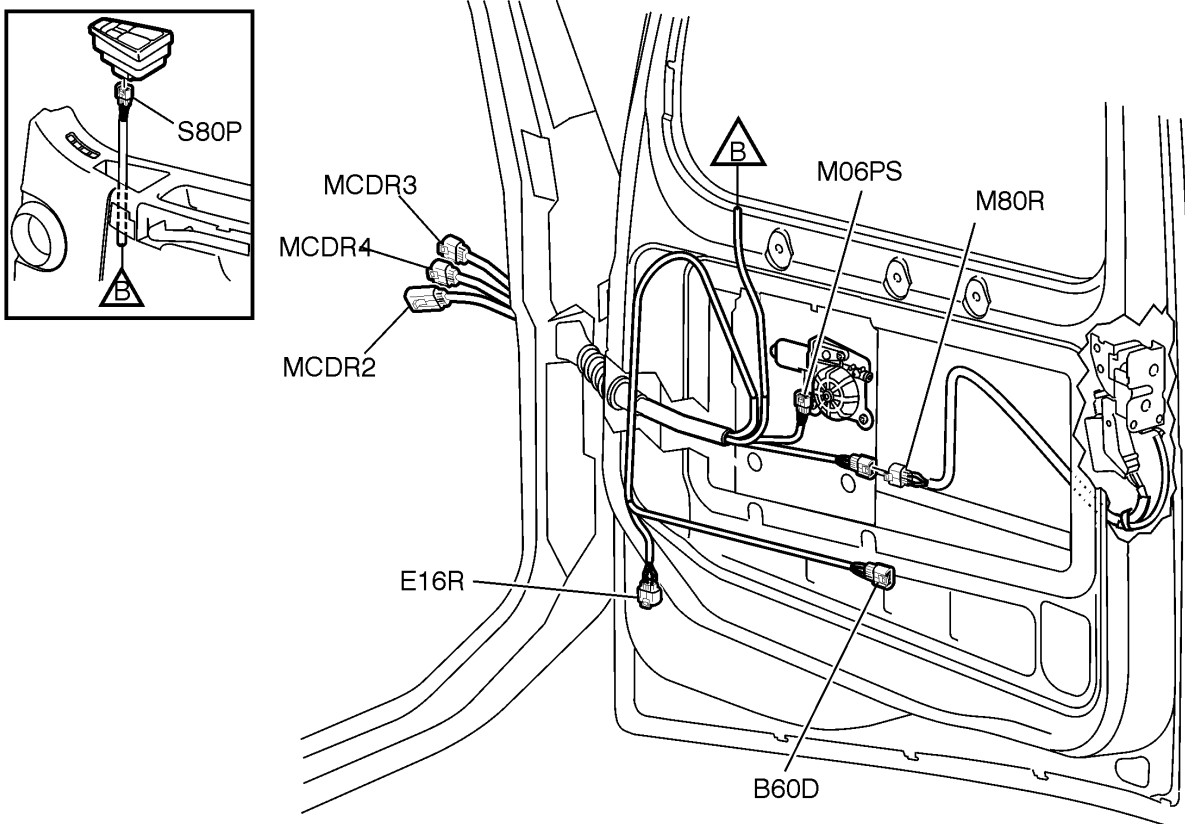
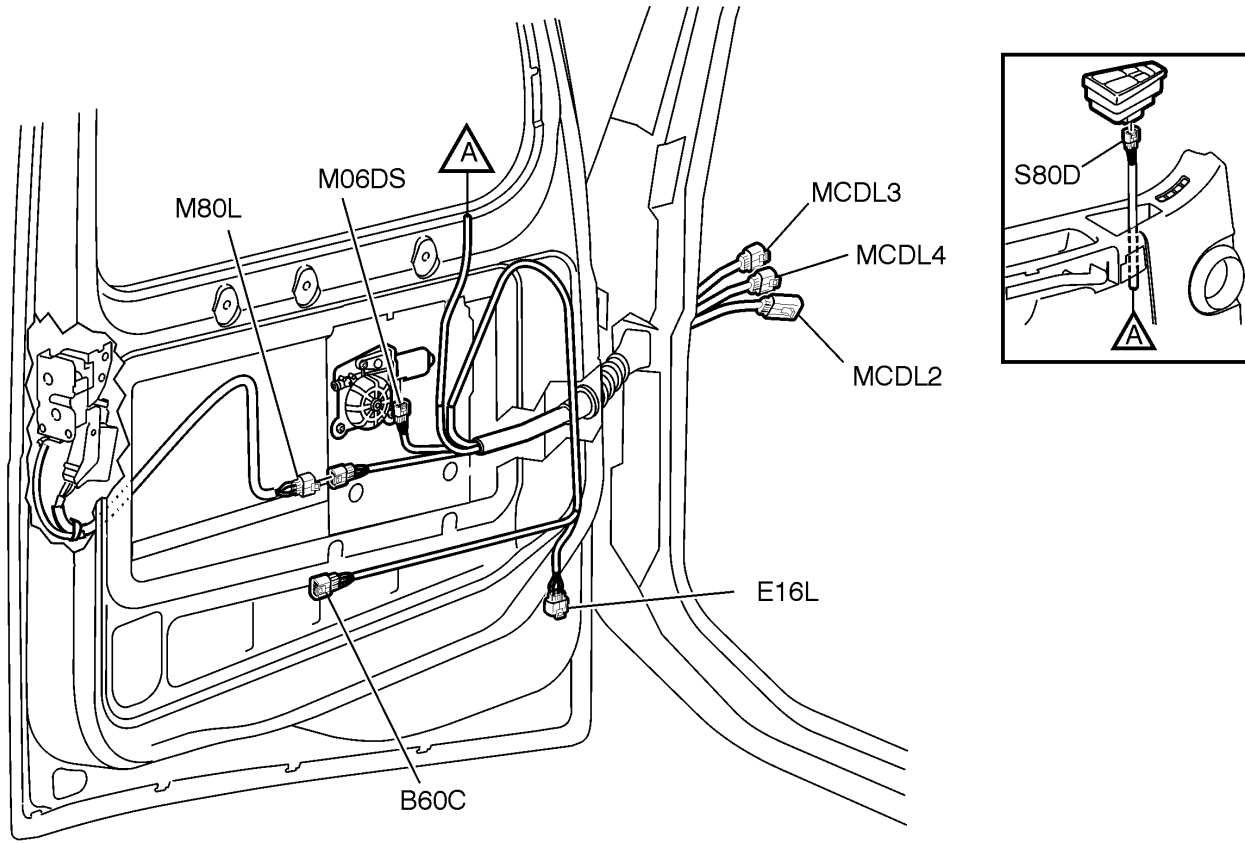

W3005921

Side Mirrors

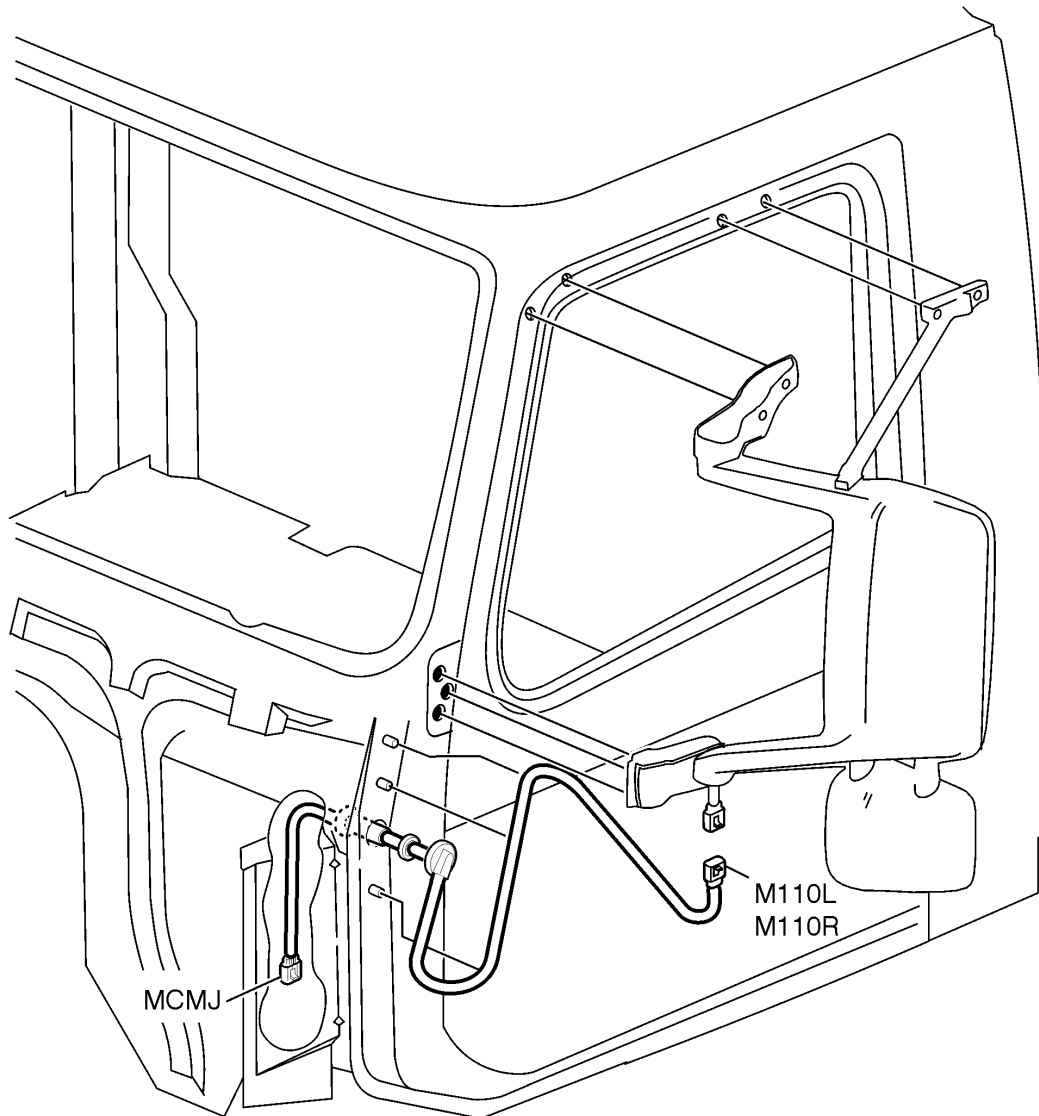

Side Markers

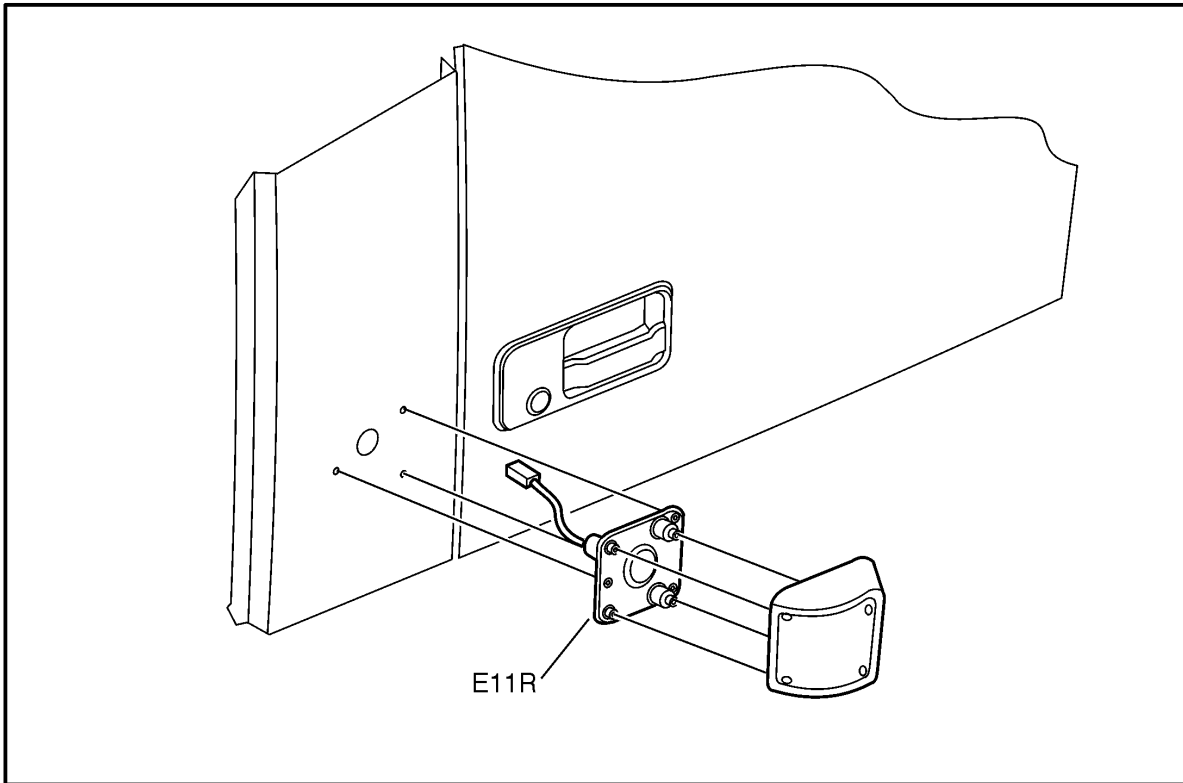
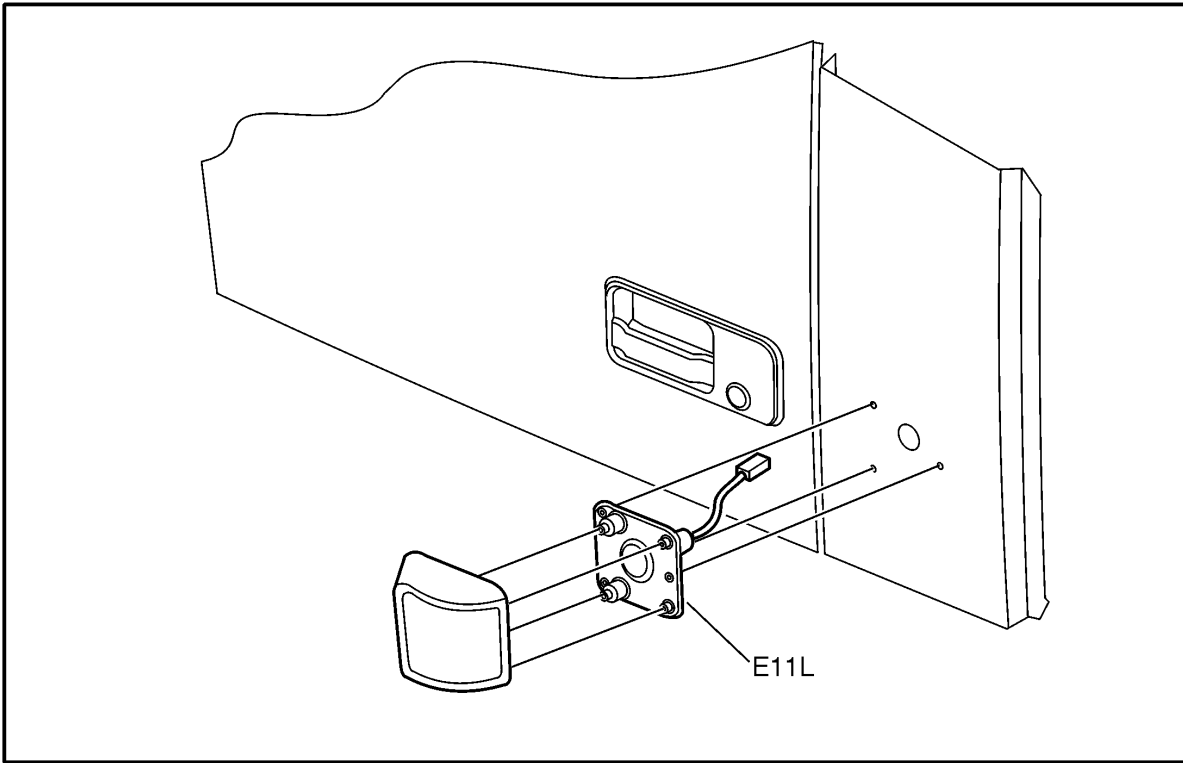

Roof Sign Harness

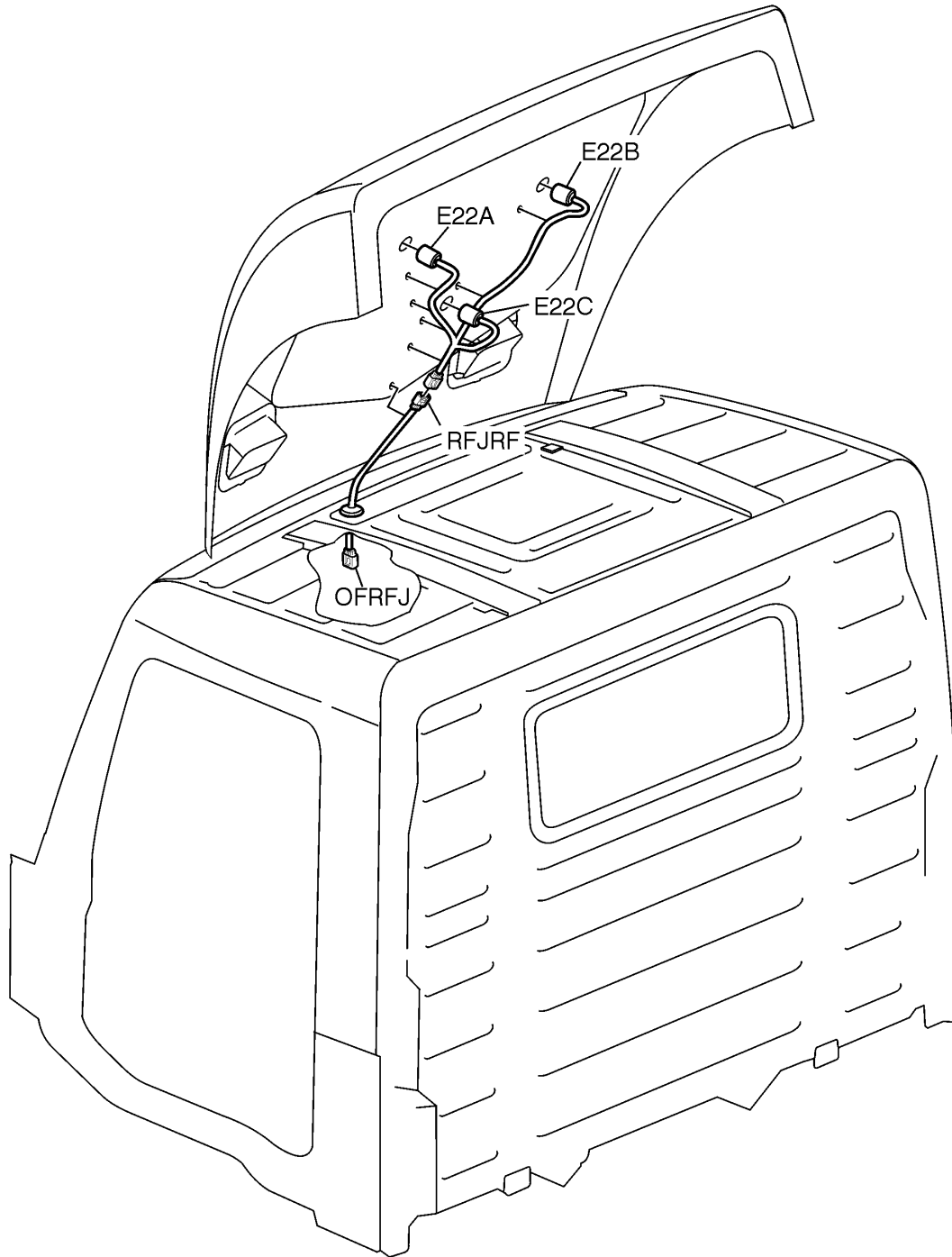

Overhead Marker Lights

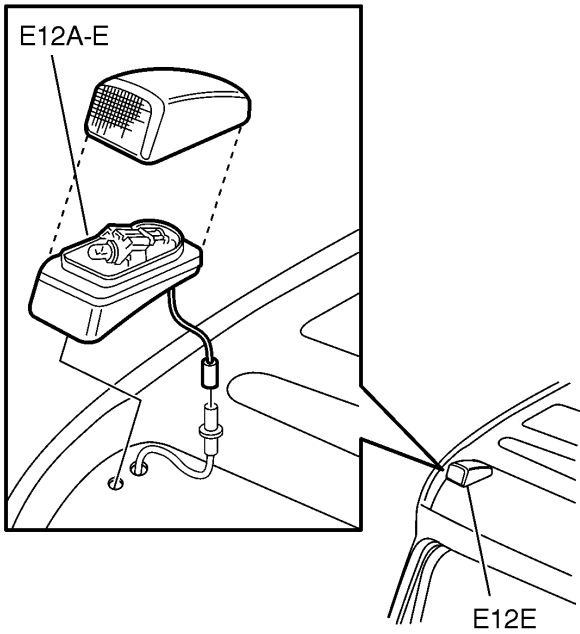
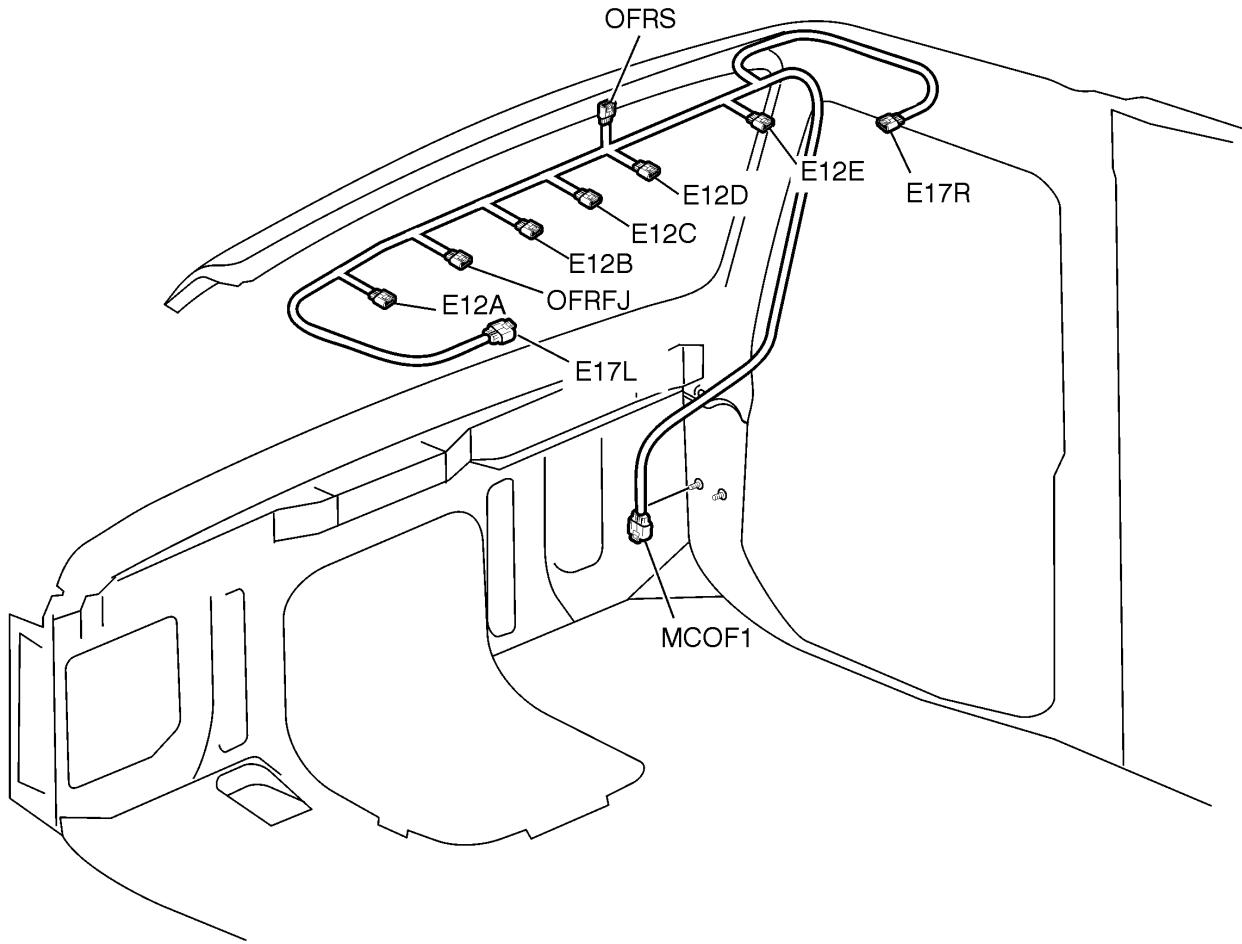

Sunvisor Harness (Daycab, VN430 and 630)

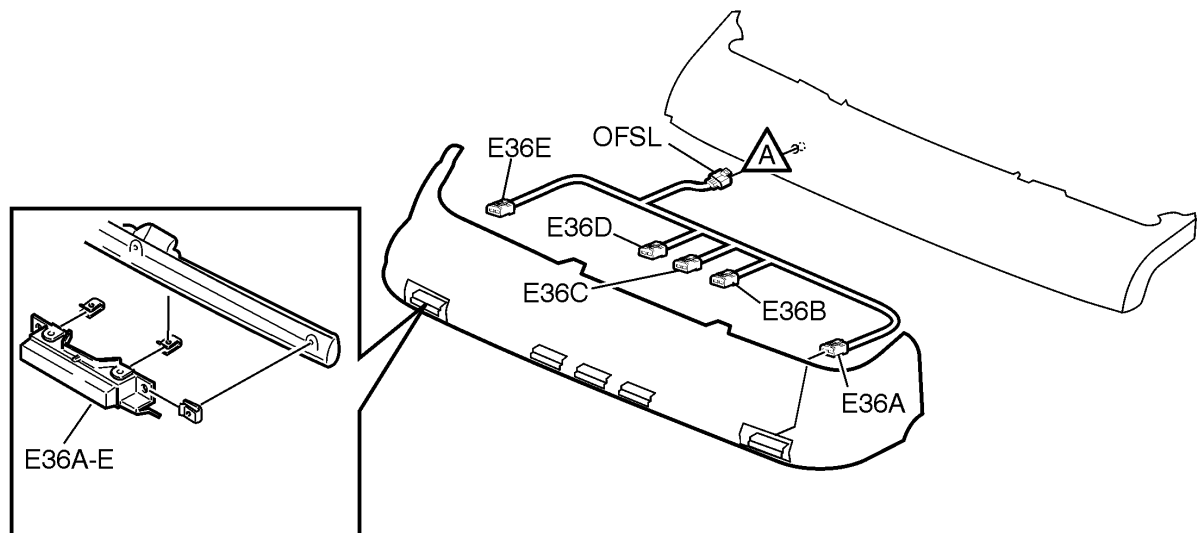
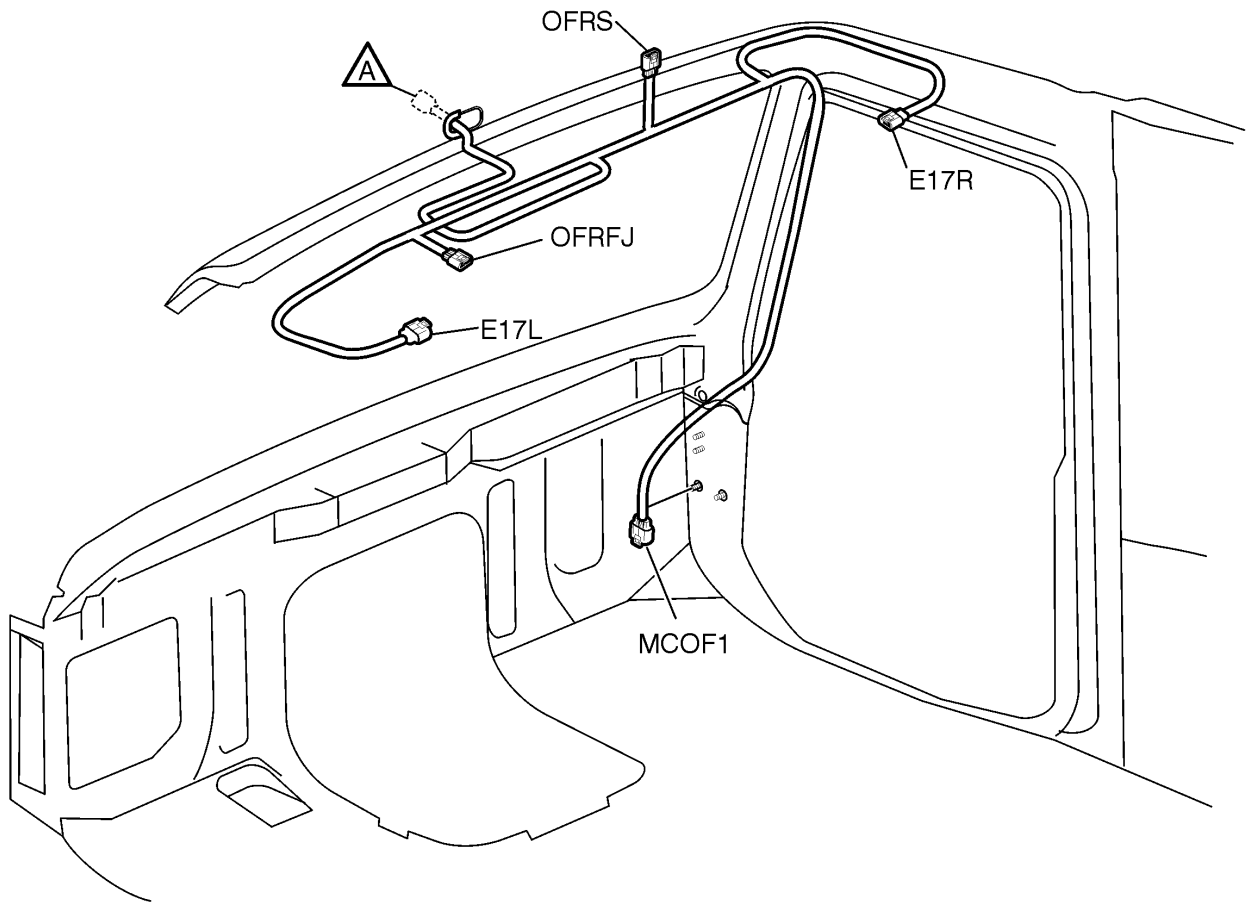

Sunvisor Harness (VN670 and 780)

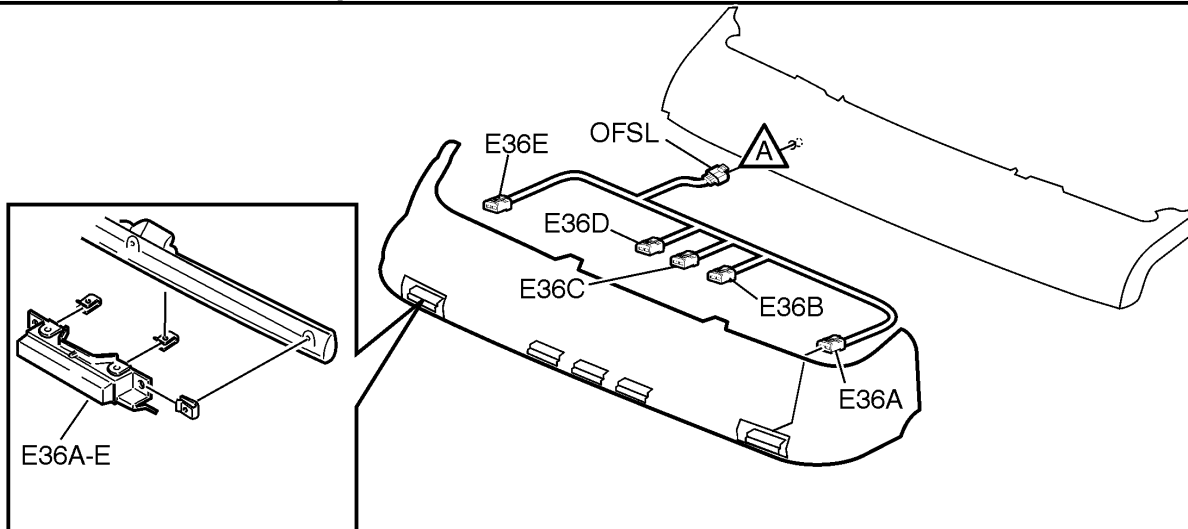
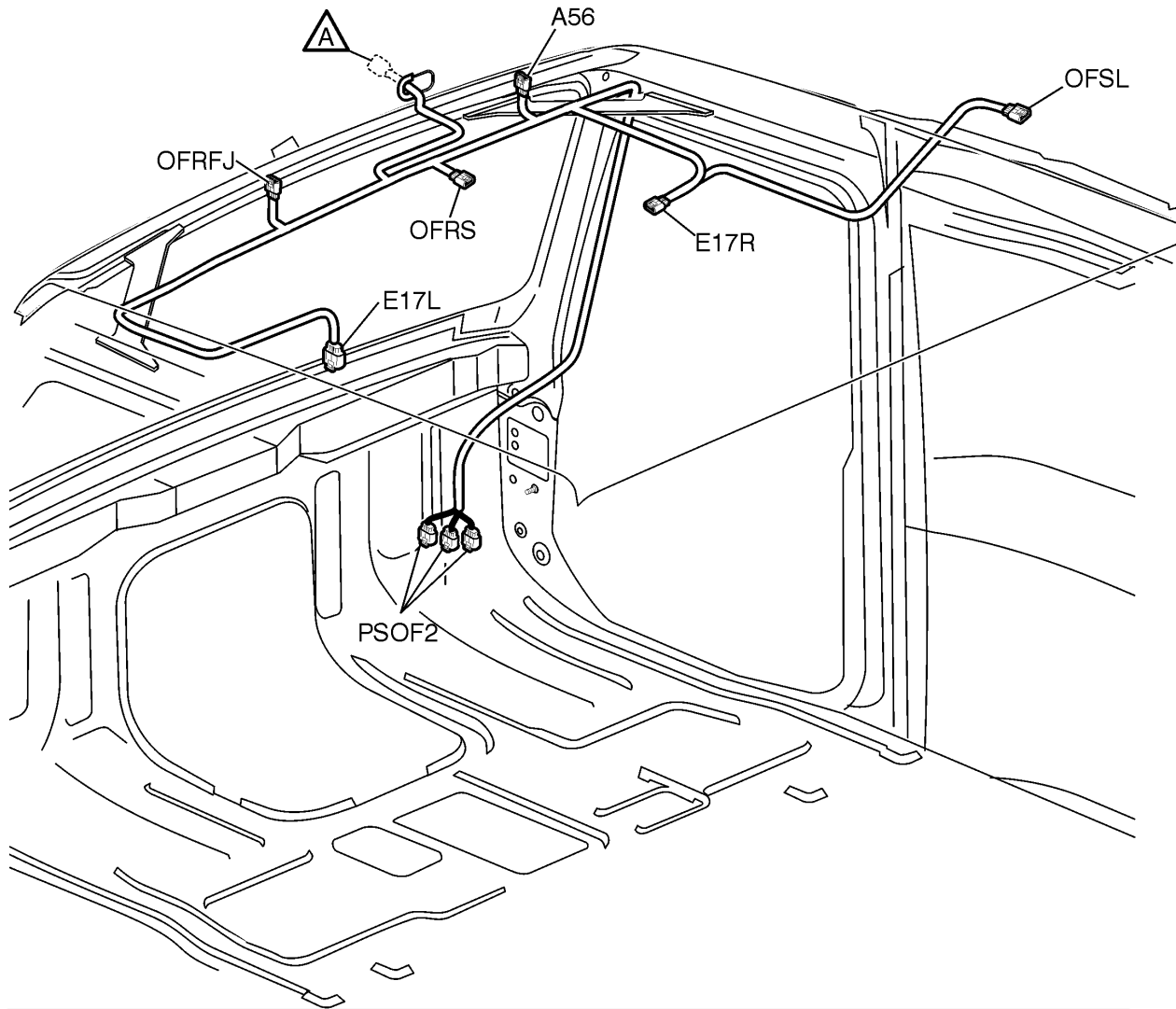

Trailer Cable Connections

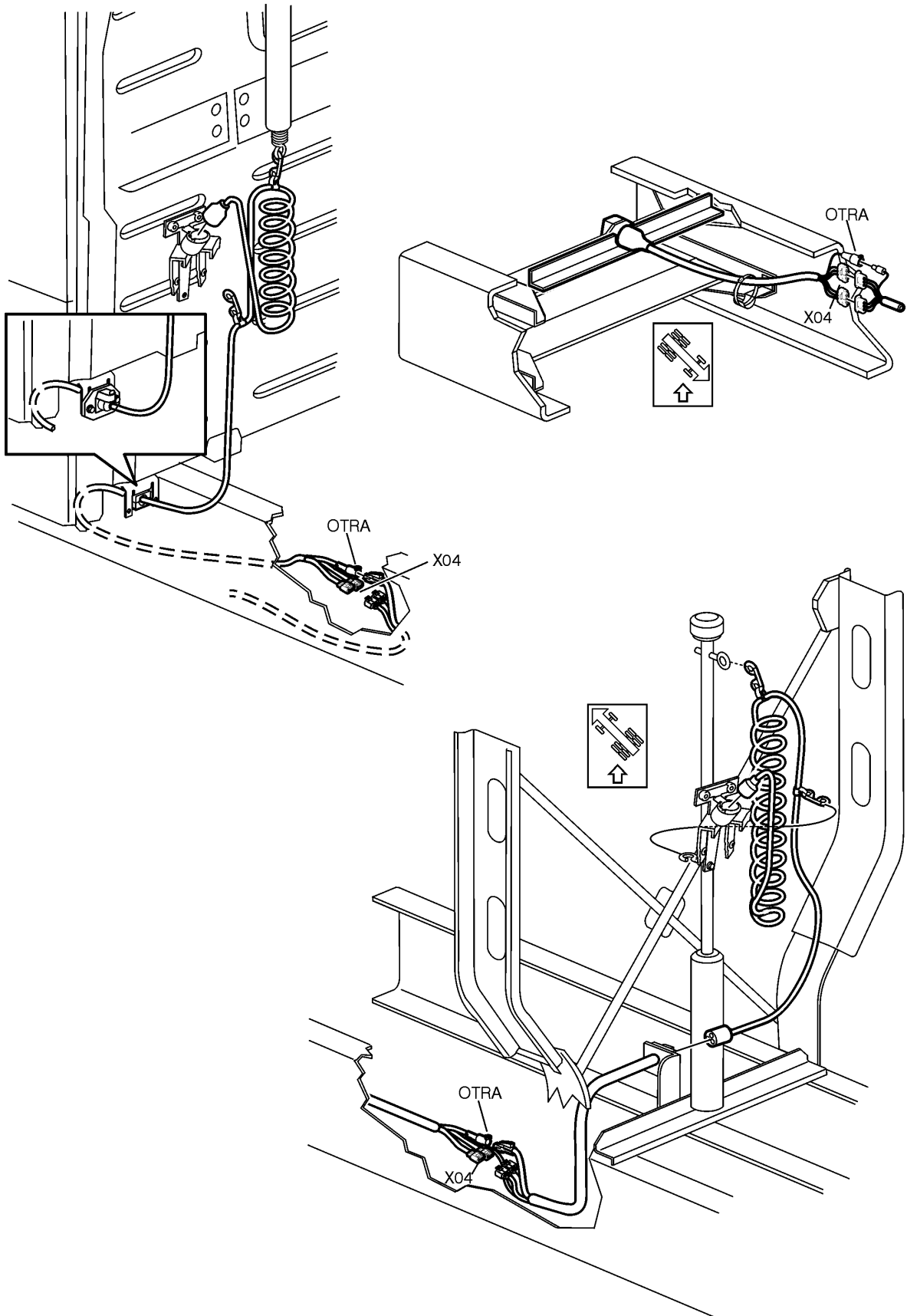

Bodybuilder Box, VHD

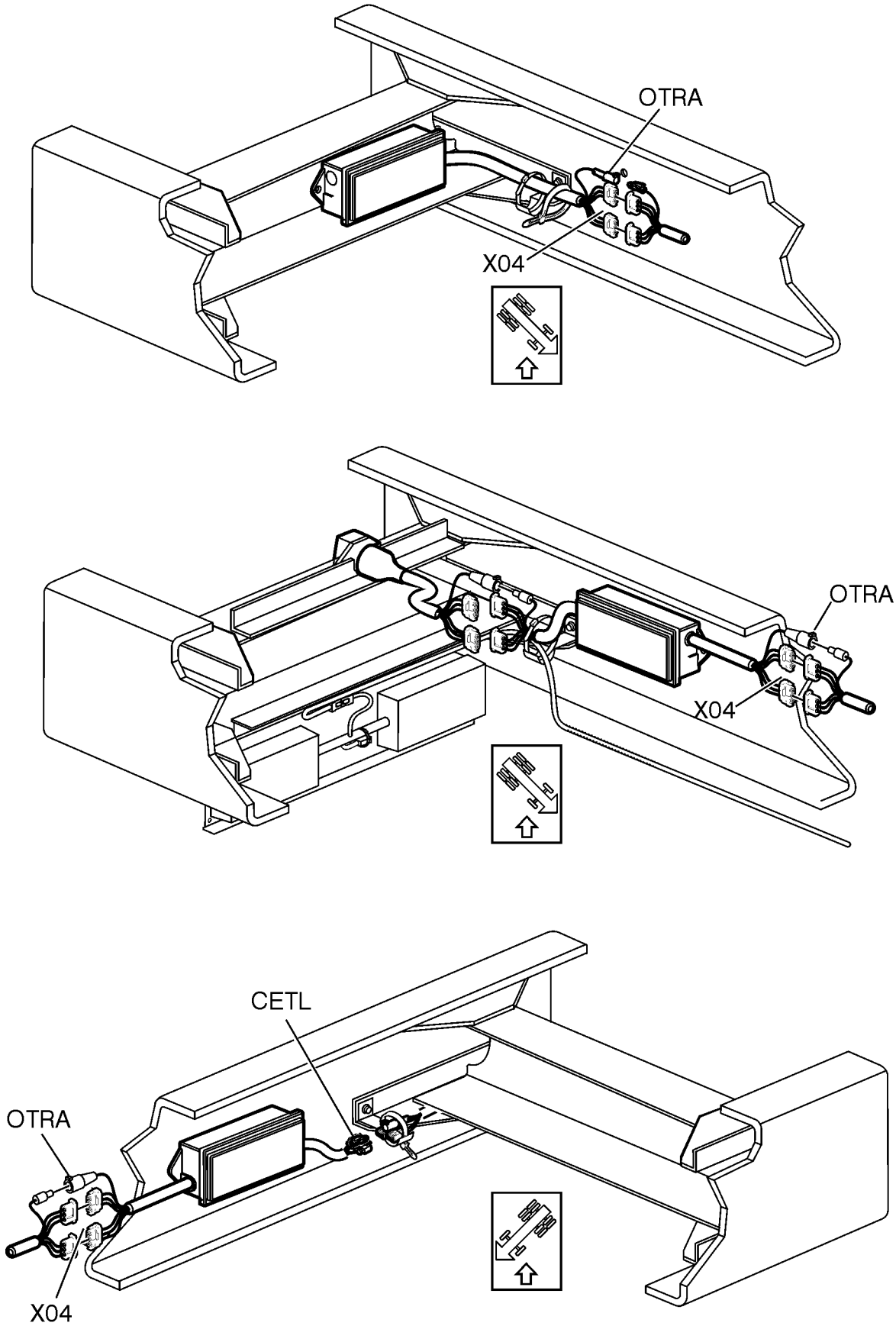

W3006369

Headlight Harness, VHD

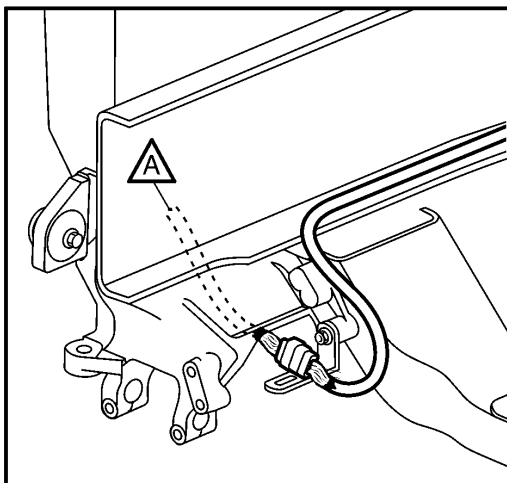
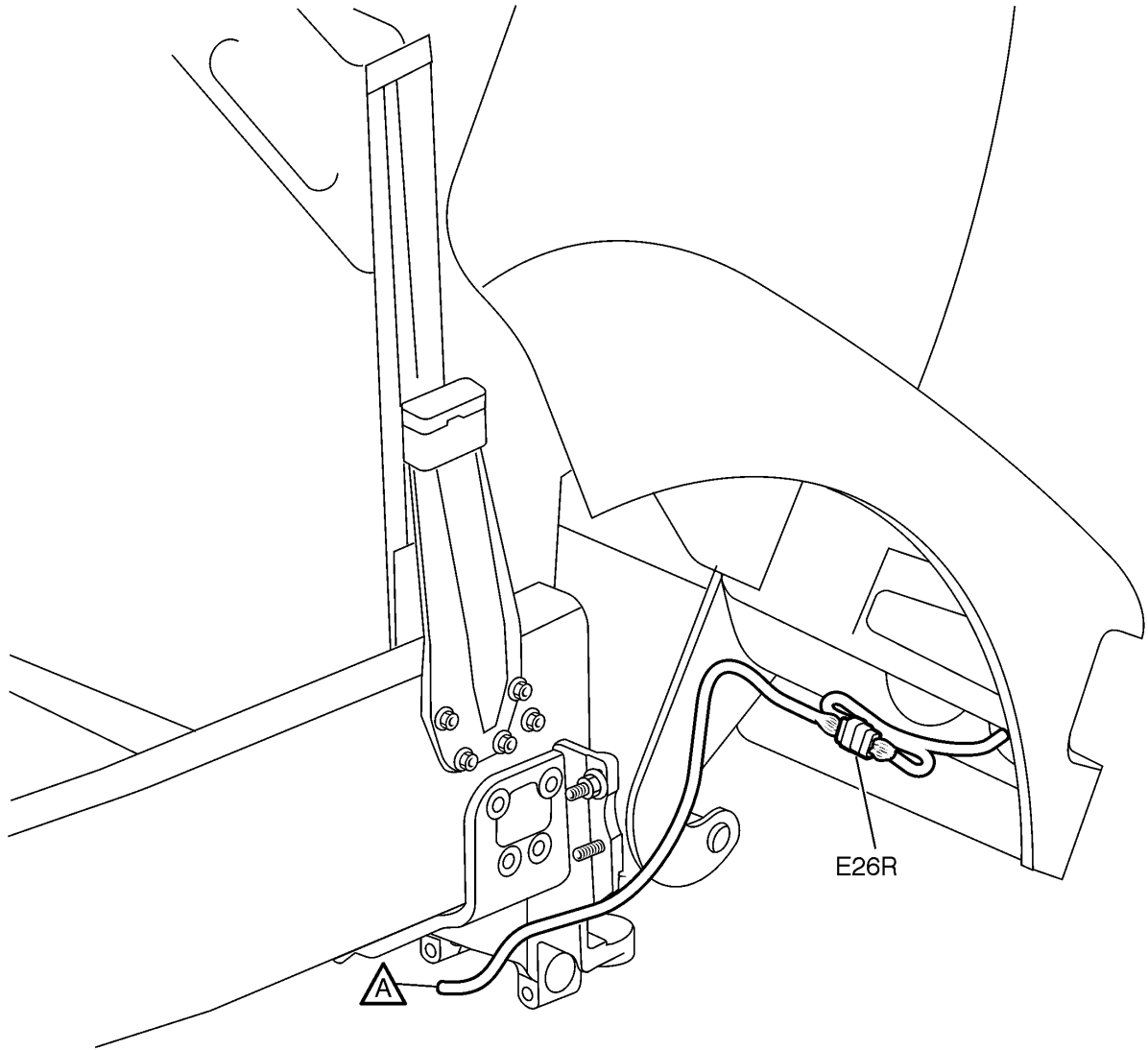

Headlight Harness, VNM

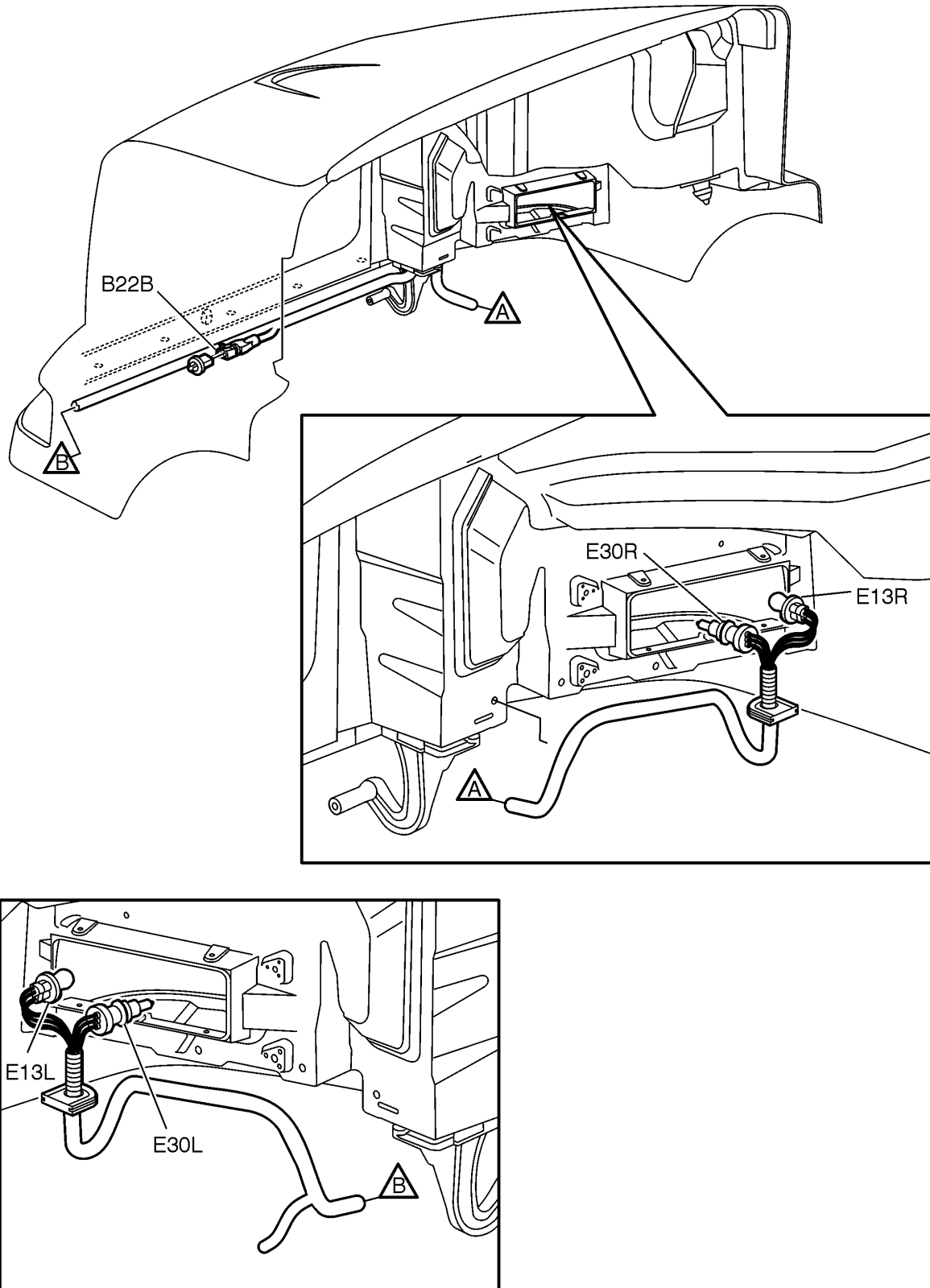

W3005901

Headlight Harness, VNL

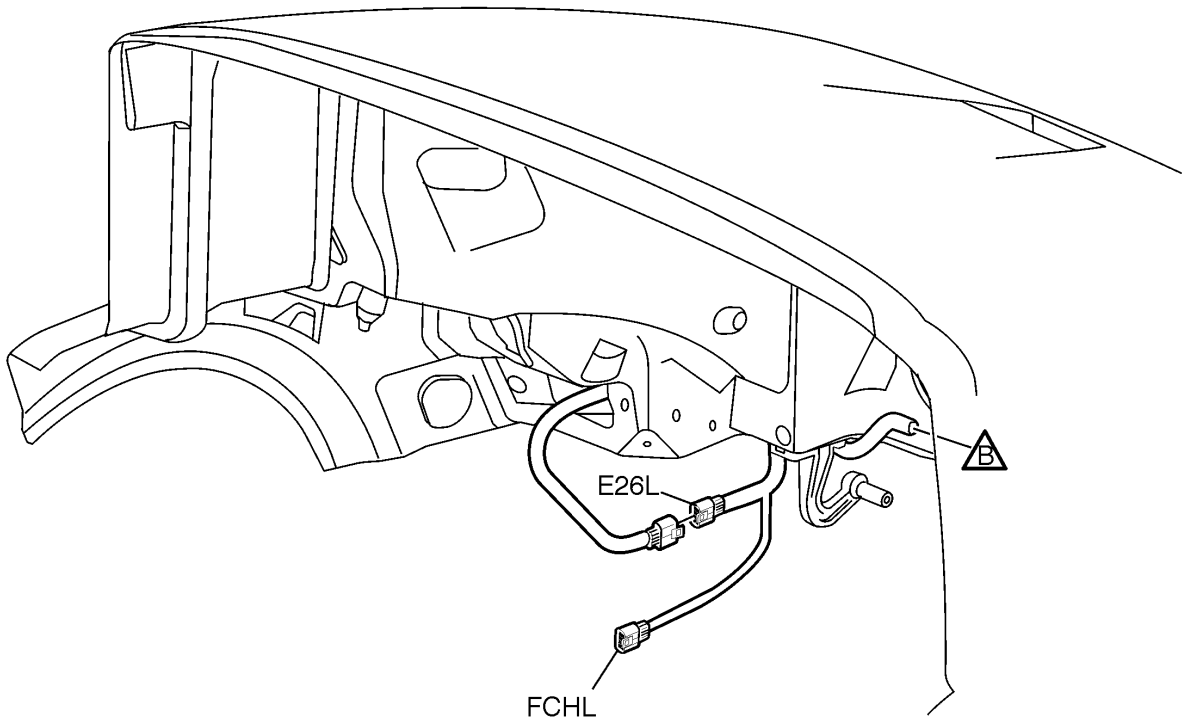
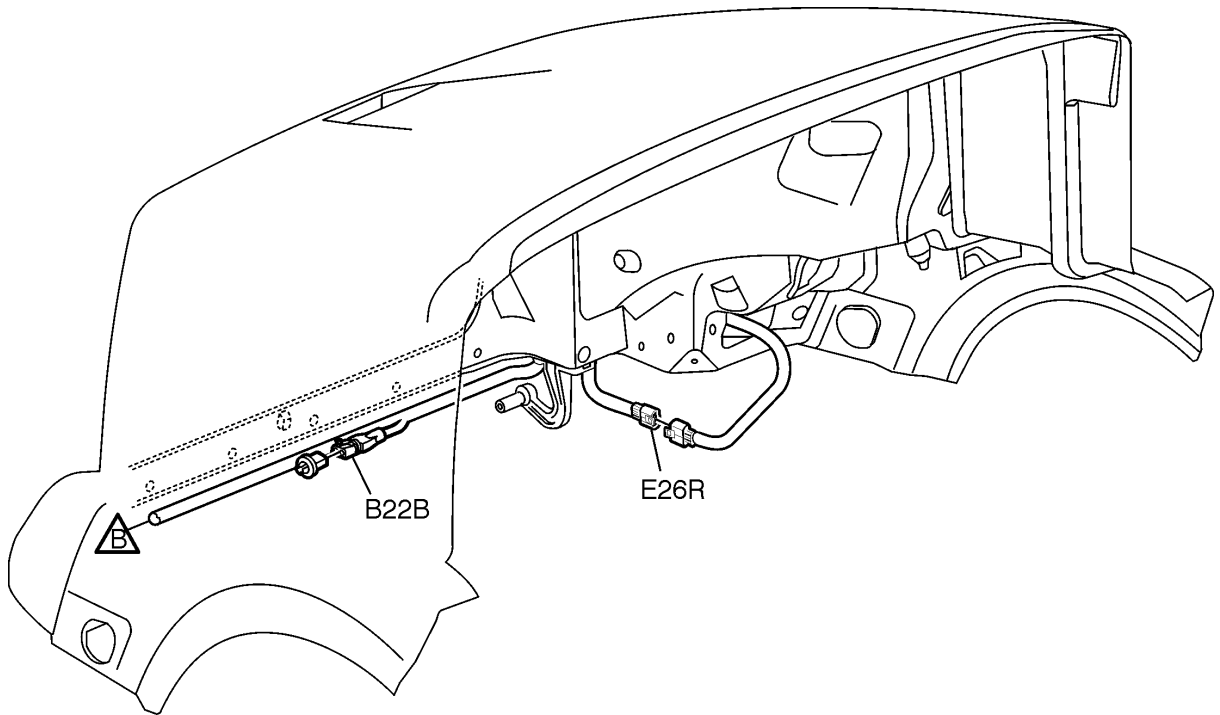

W3005898

Fog and Driving Lights, VHD

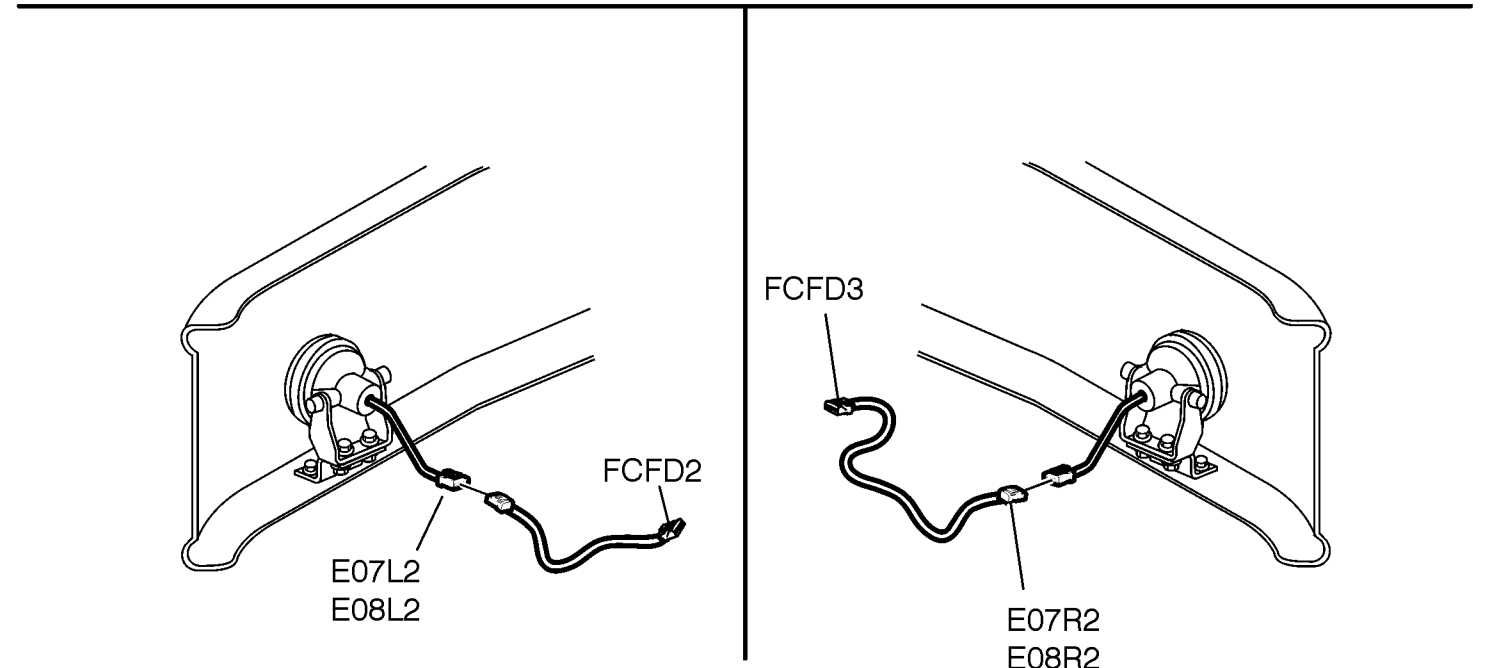
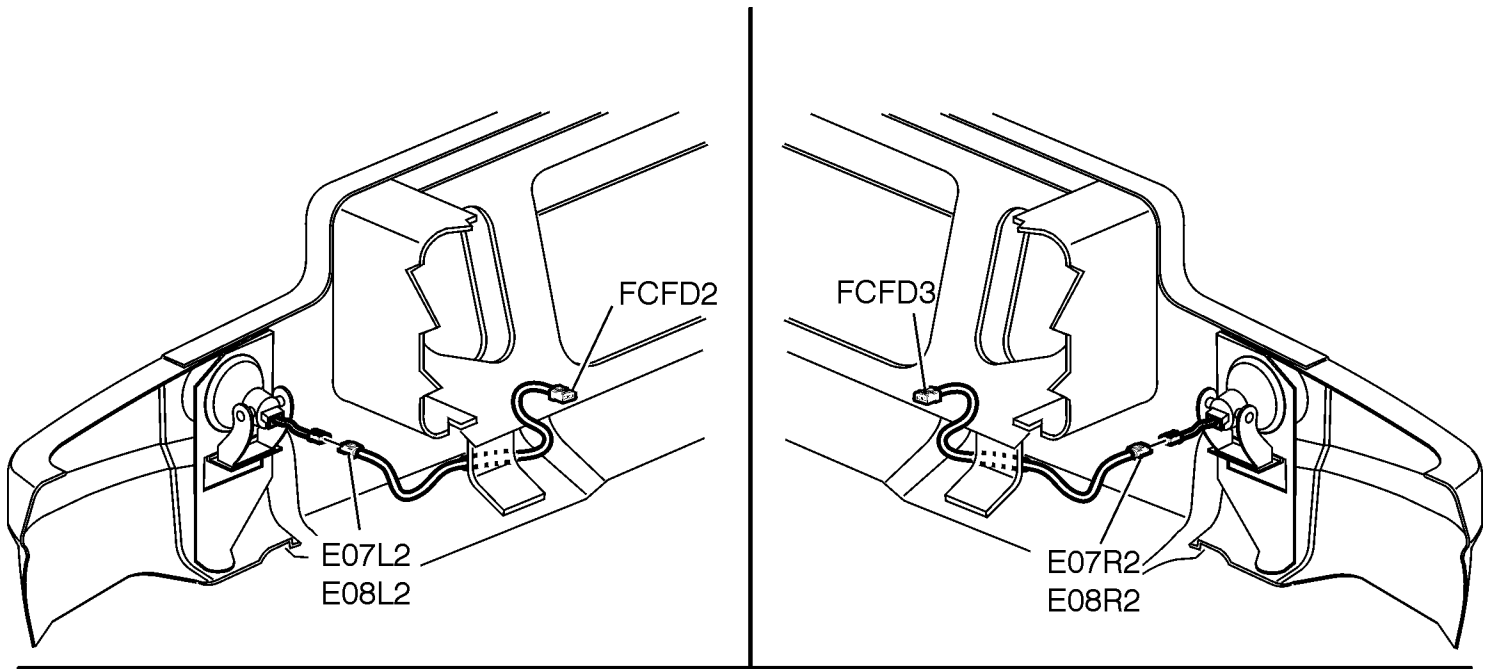

W3005952

Fog and Driving Lights, VNL and VNM

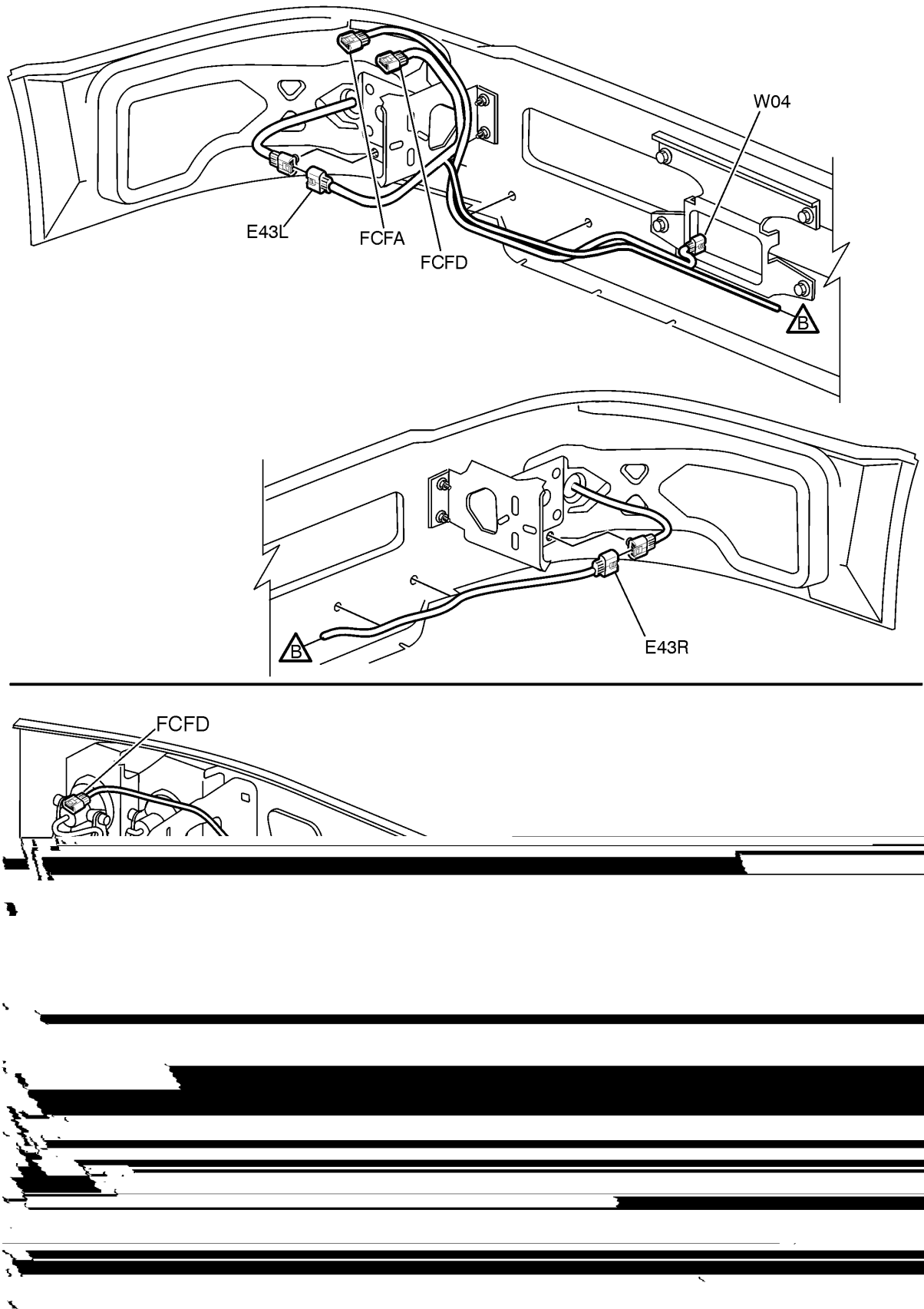

W3005933

Tail lights

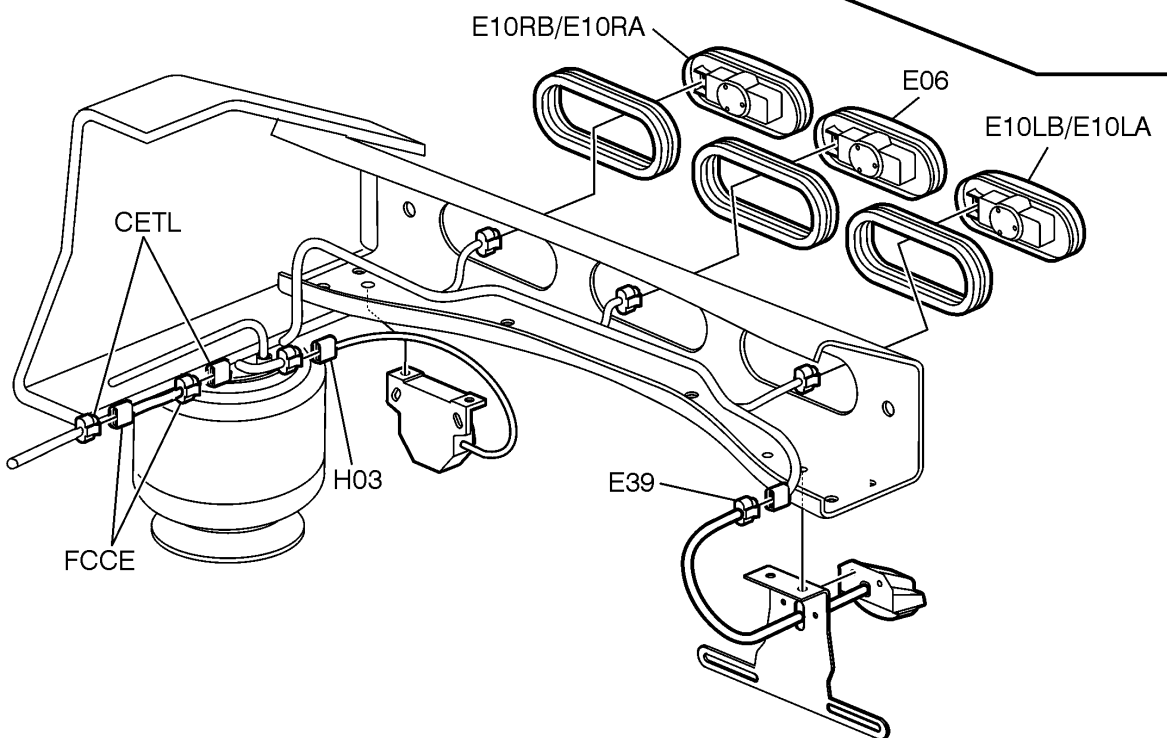
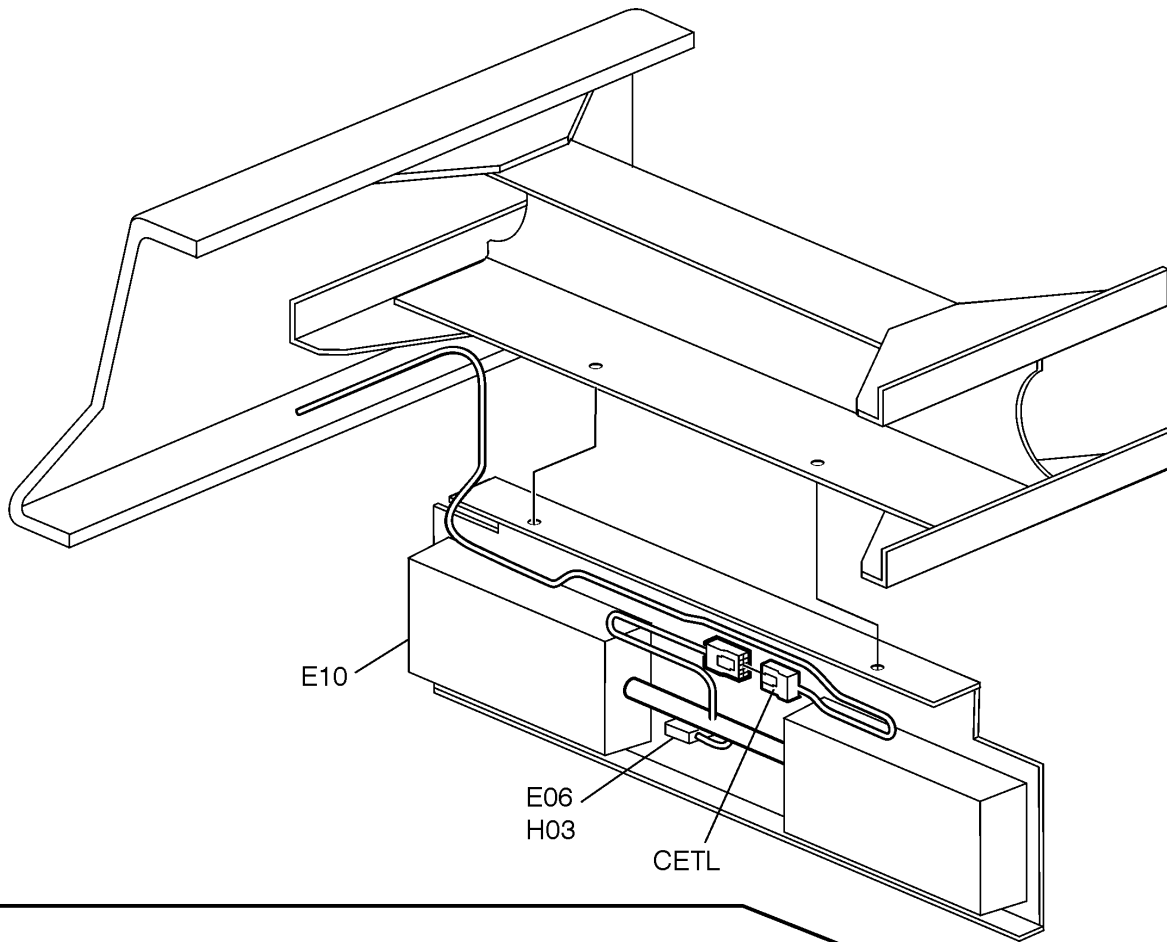

Alternator (typical view)

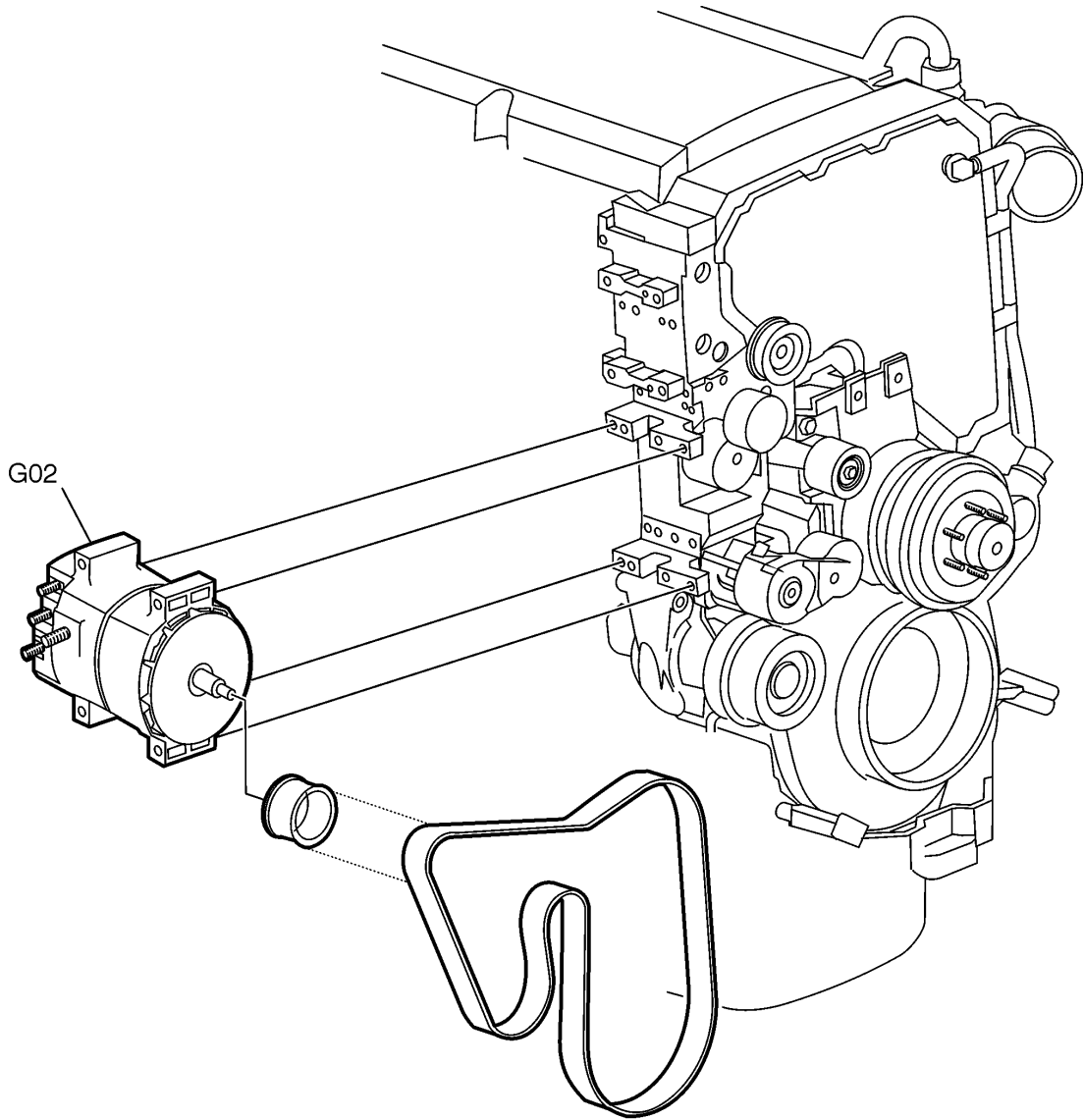

W3005908

D12D

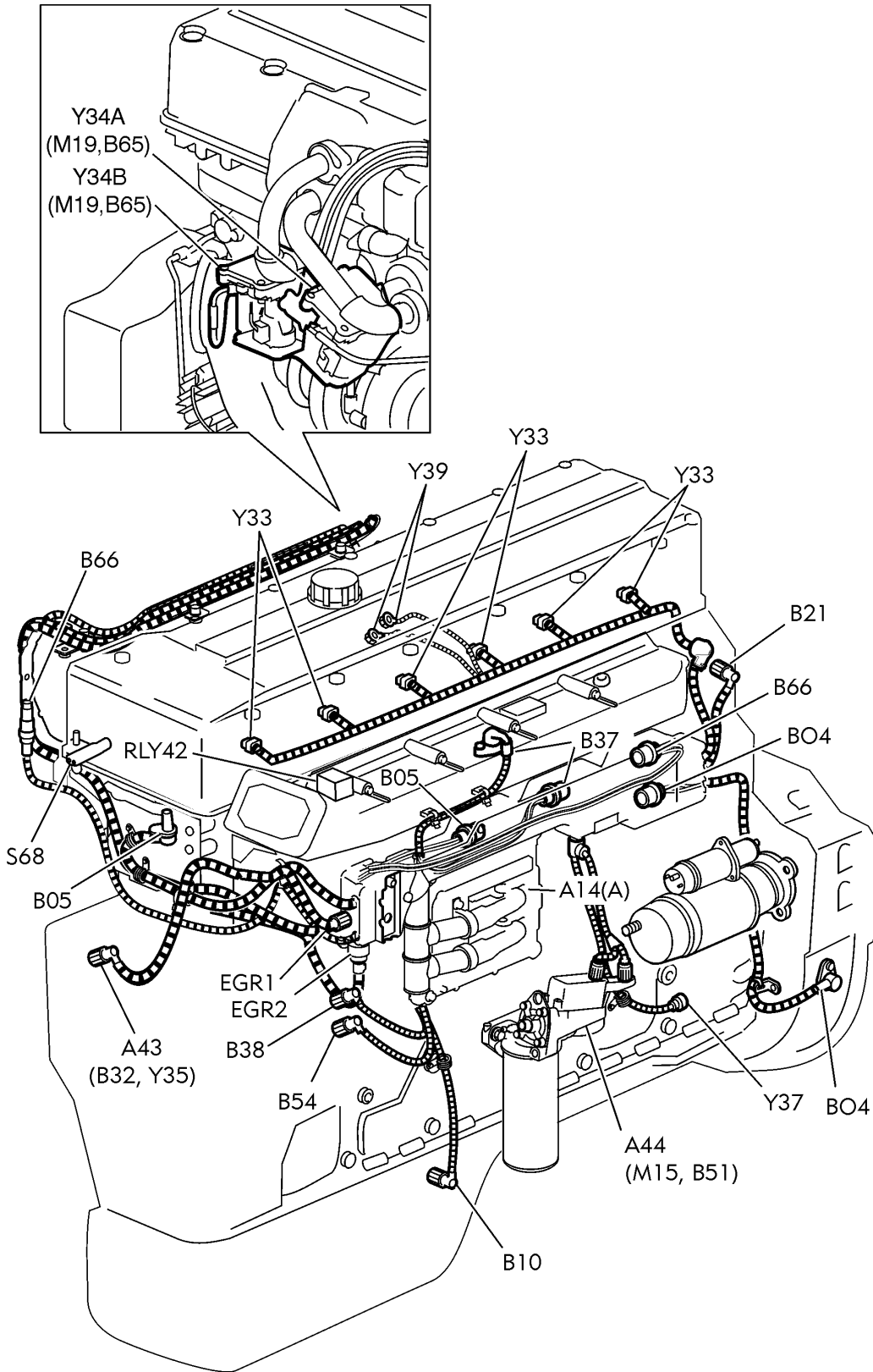

W3006510

D12D (Continued)

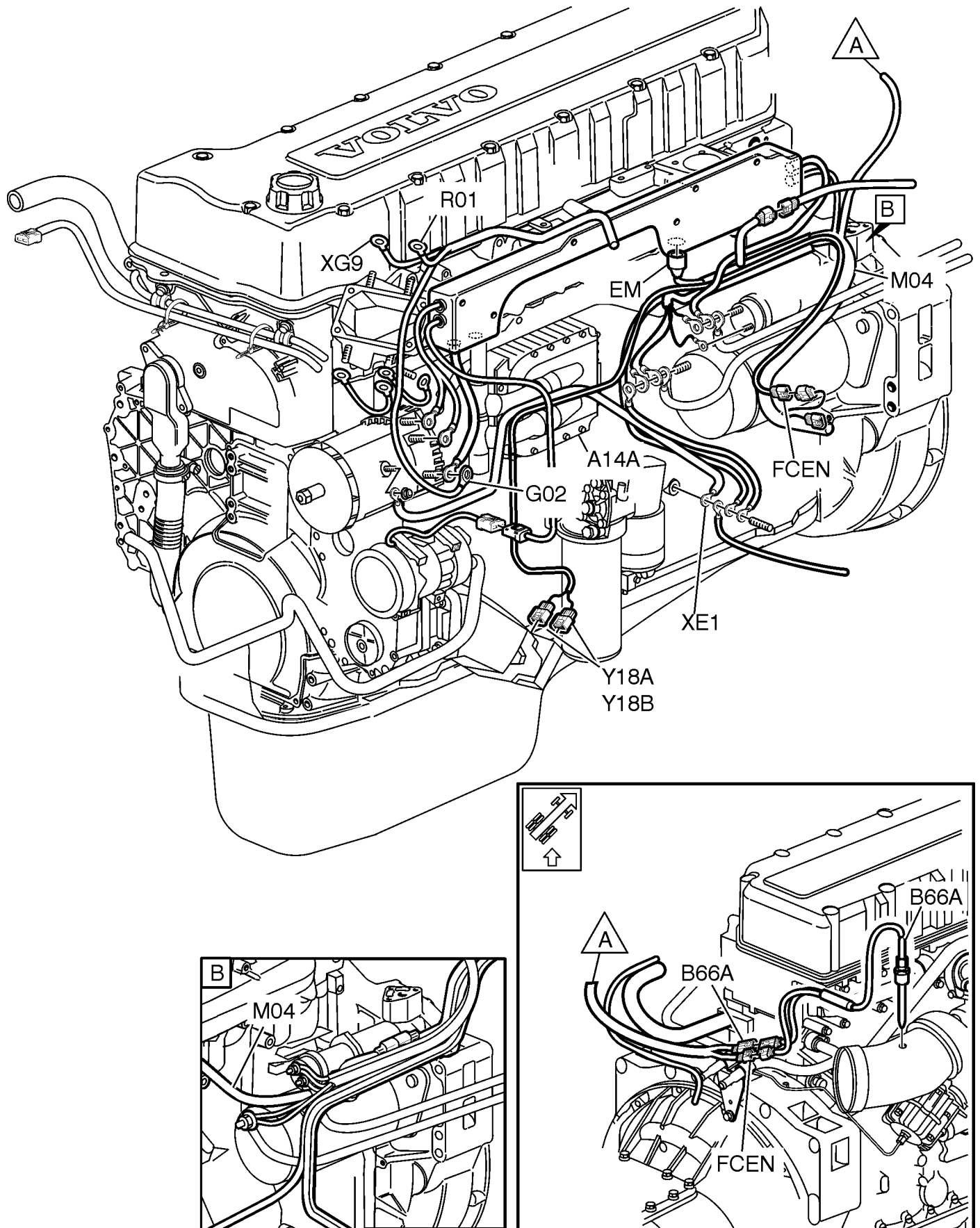

Engine, Cummins ISX

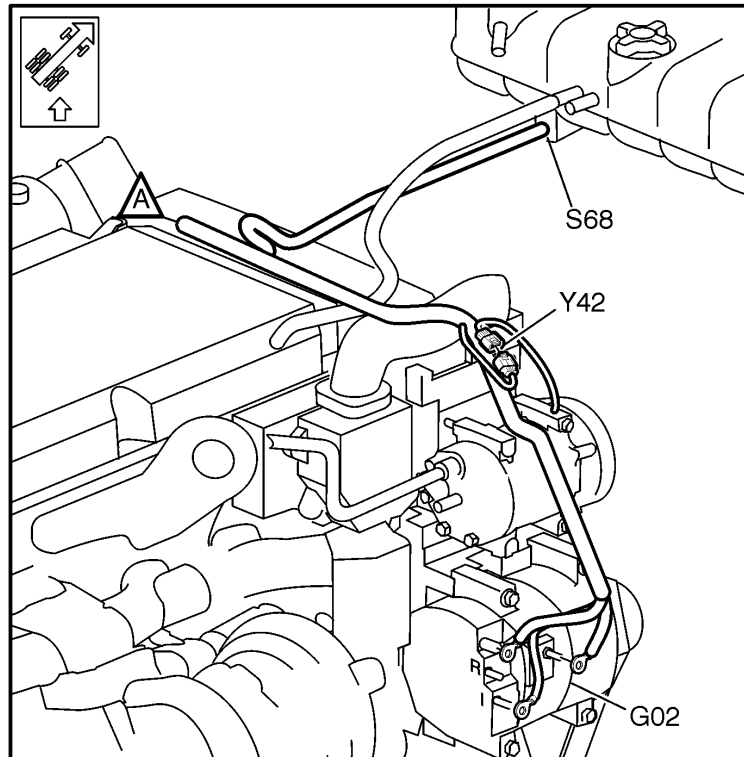
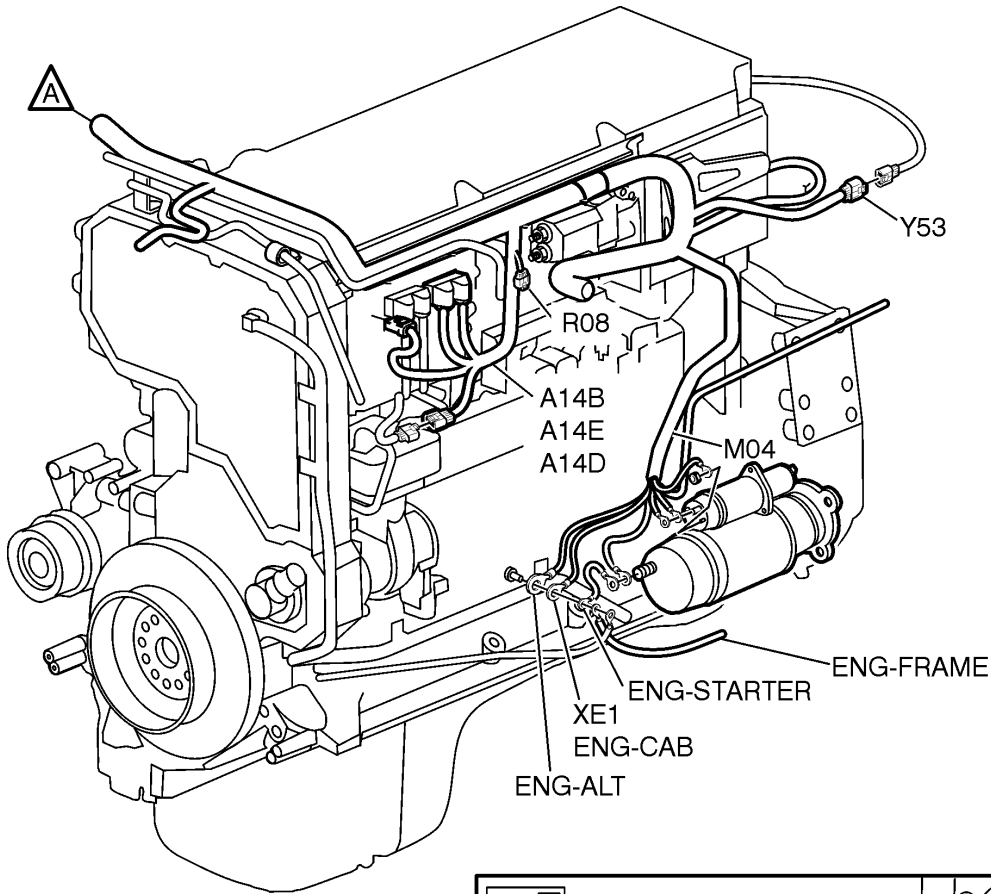

W3006509

Allison HD Transmission, VHD (BBOX-LF)

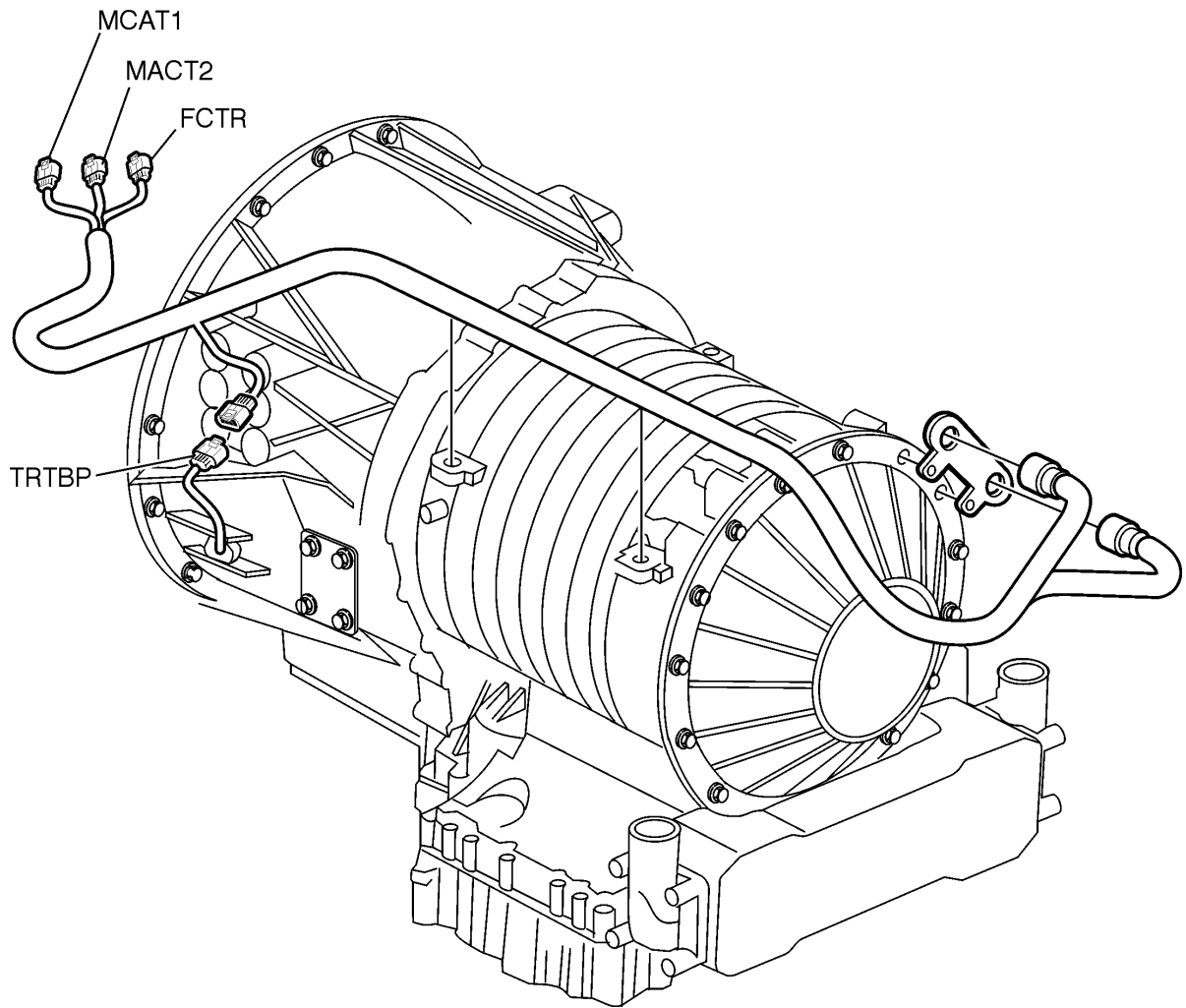

W3005911

Allison HD Transmission, VHD (BBOX-LB/BBOX-RF)

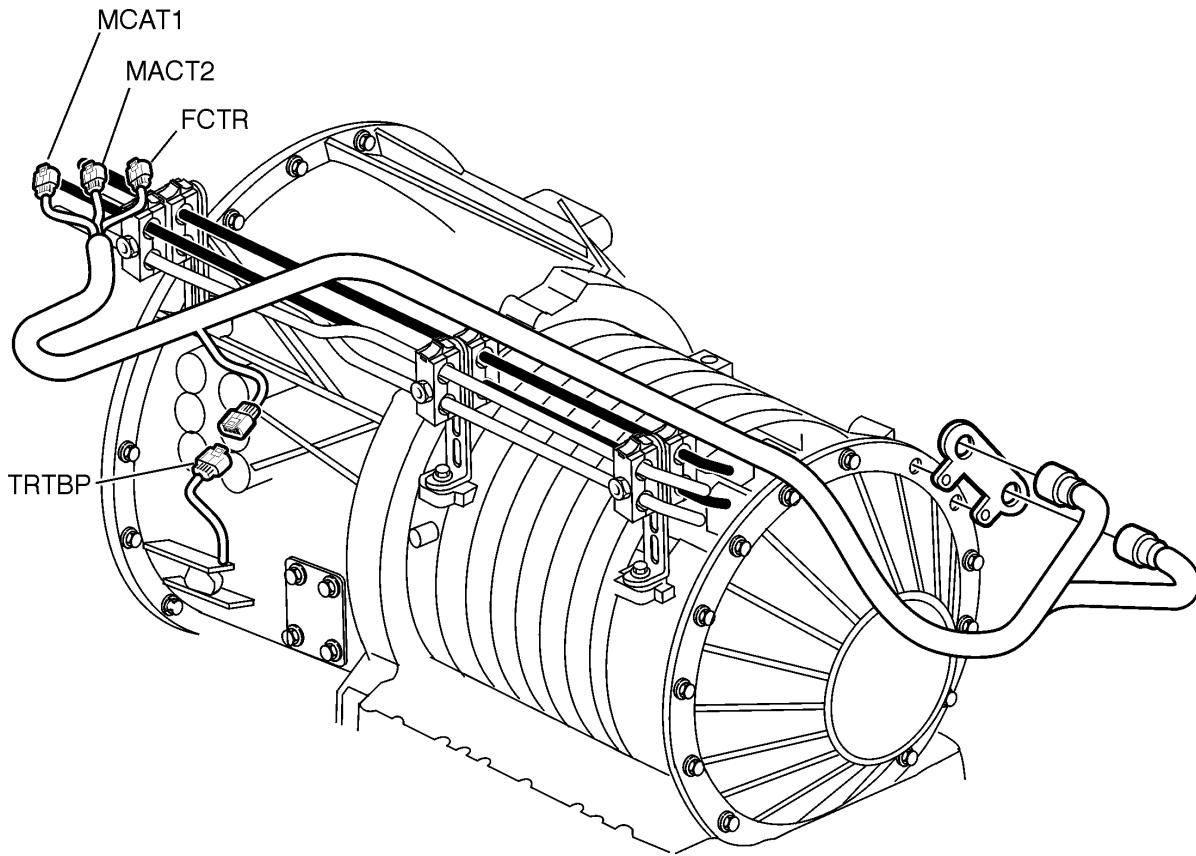

W3005912

Allison MD Transmission, VHD (BBOX-LF)

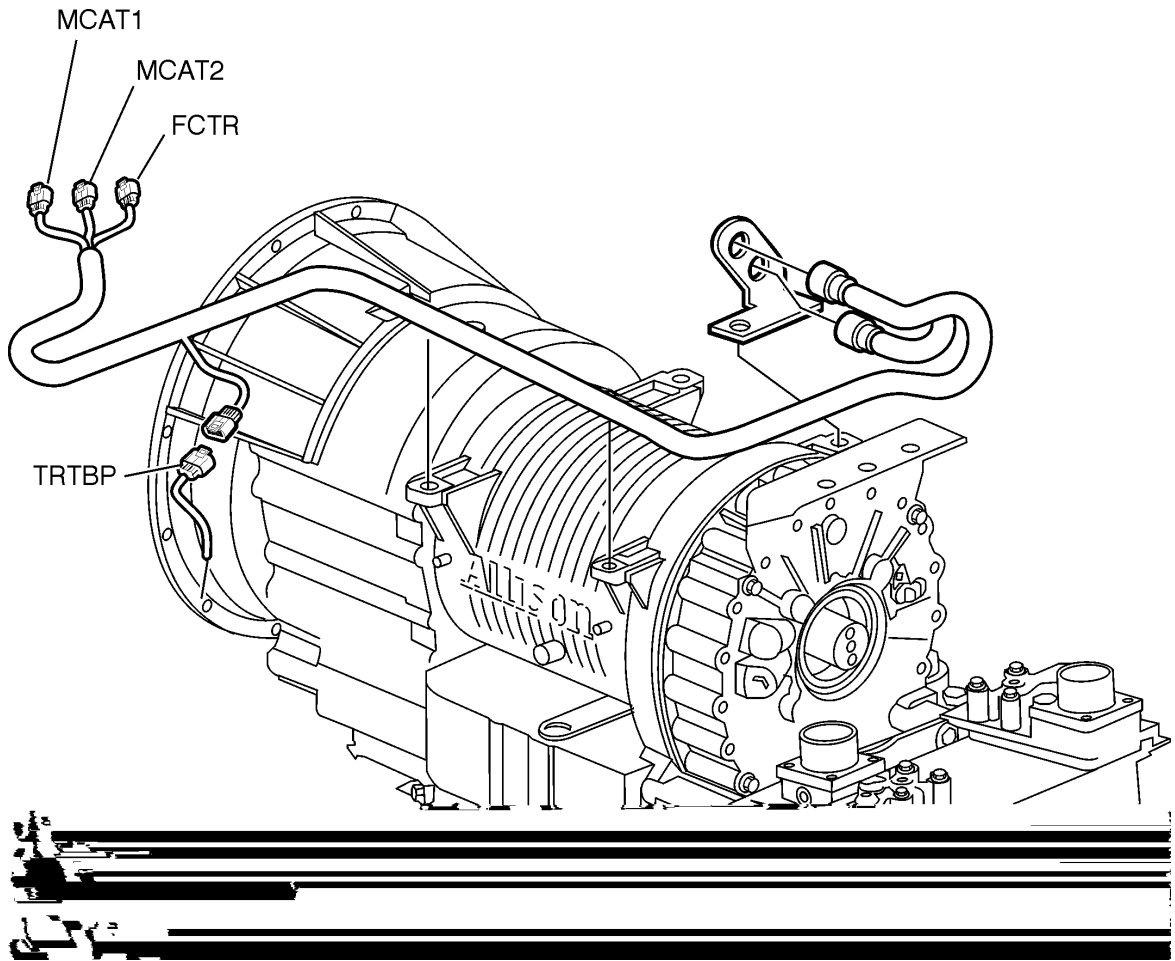

W3005914

Allison MD Transmission, VHD (BBOX-LB/BBOX-RF)

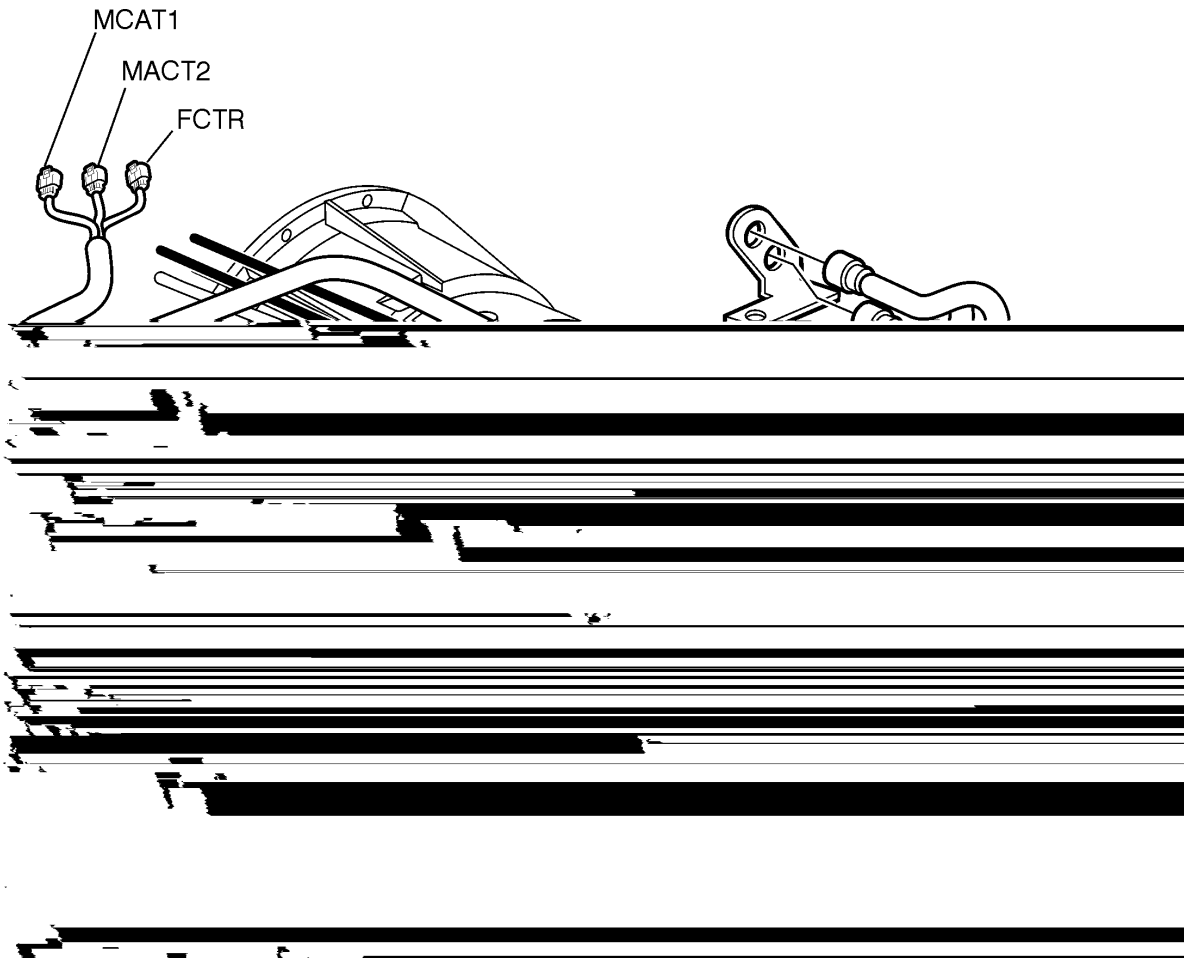

W3005913

Eaton Autoshift II Transmission

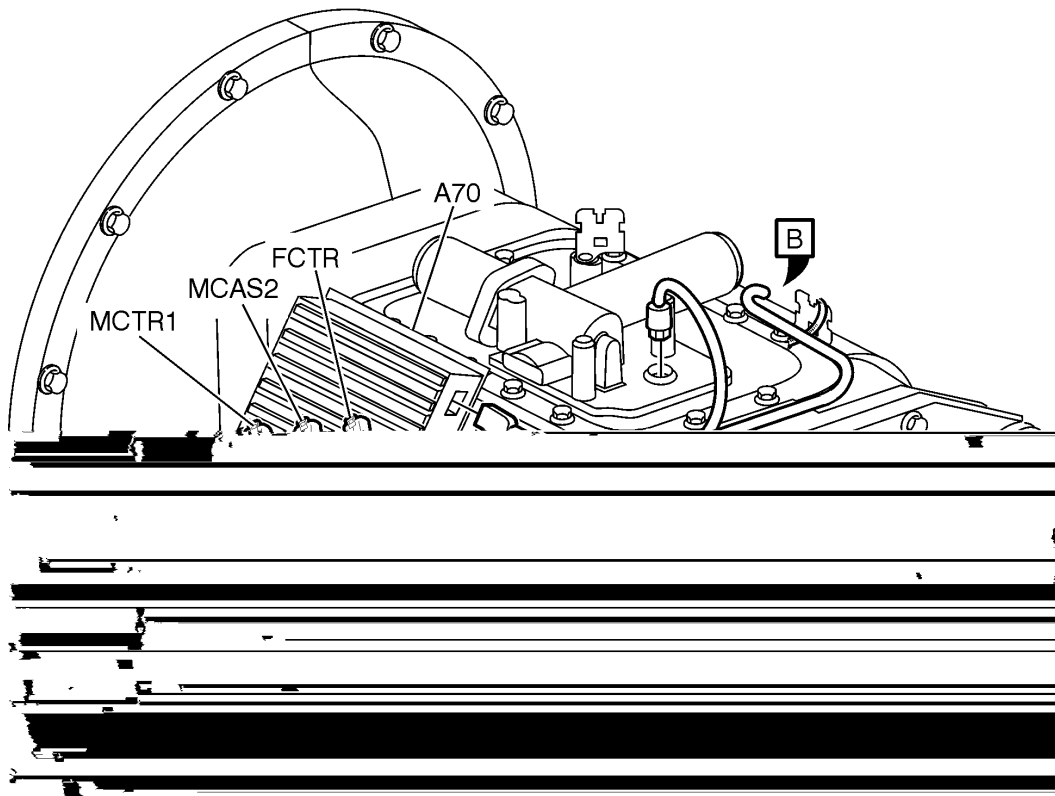
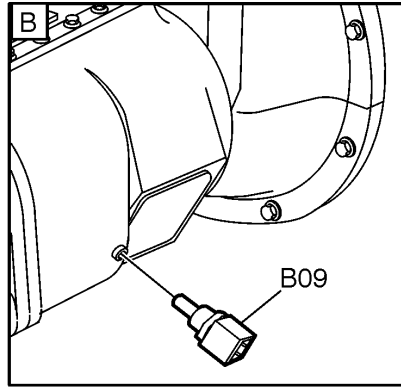

W3005890

Meritor Lighting Transmission

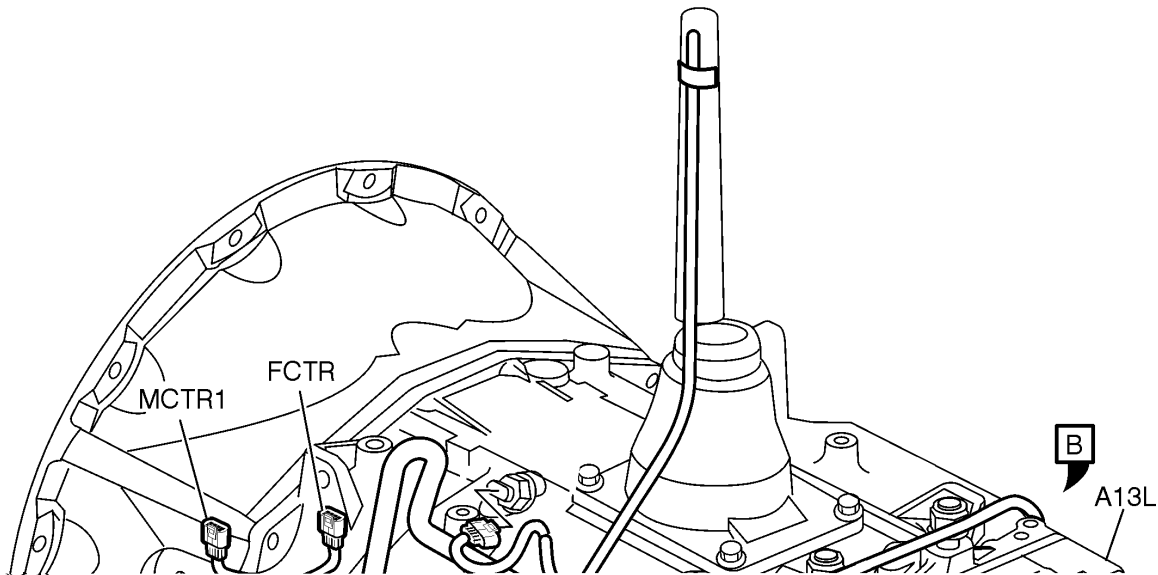
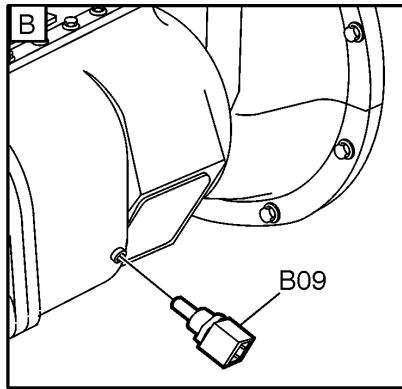

W3005891

Meritor Transmission

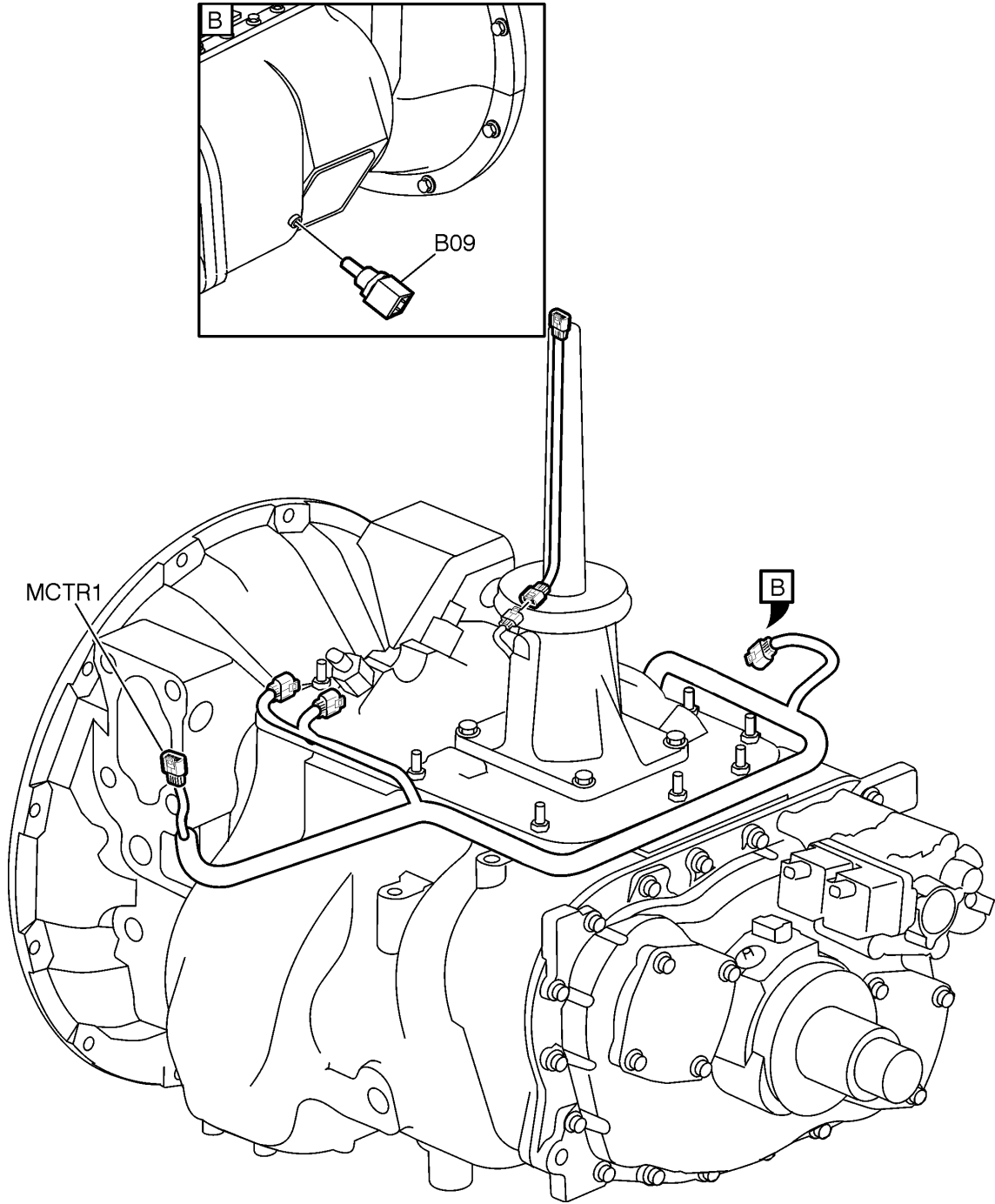

W3005892

Fuller Transmission

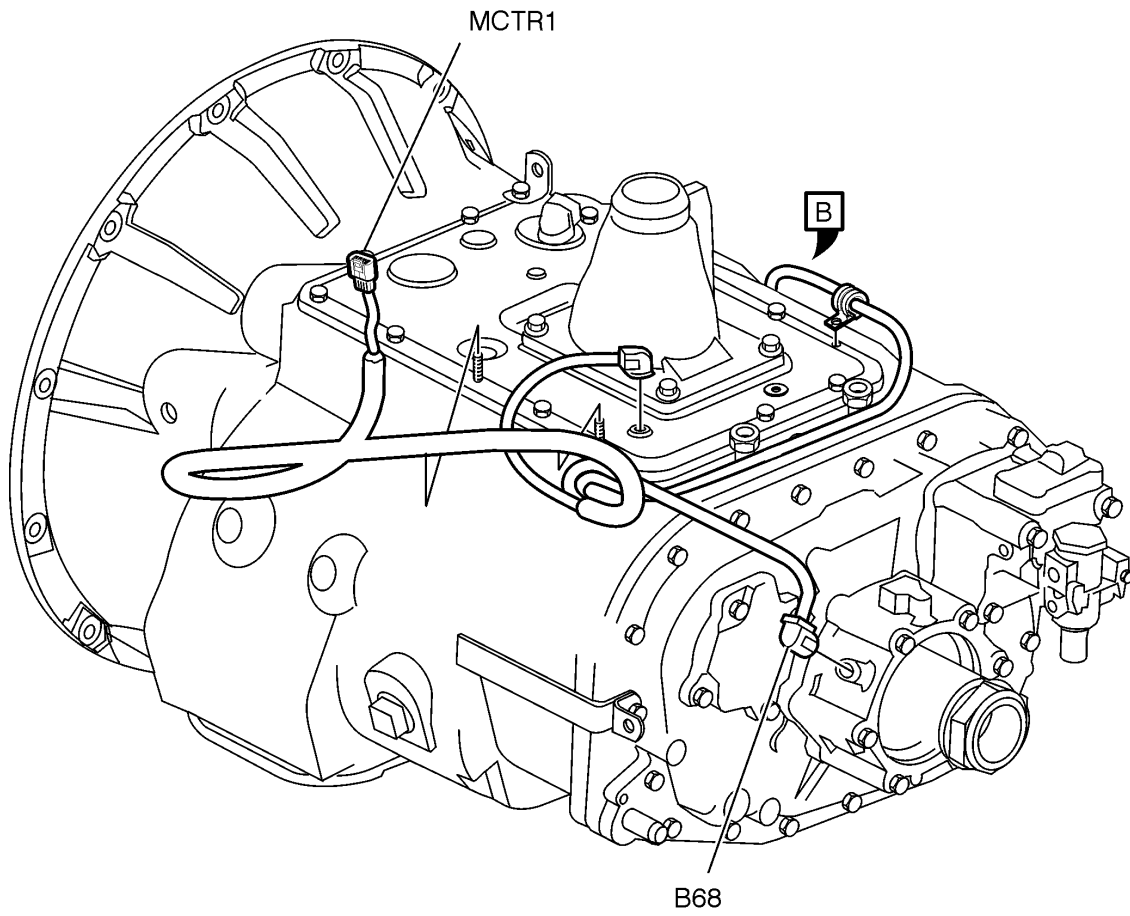
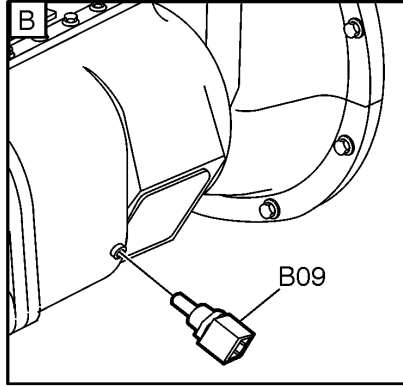

W3005893

Washer Reservoir, VN

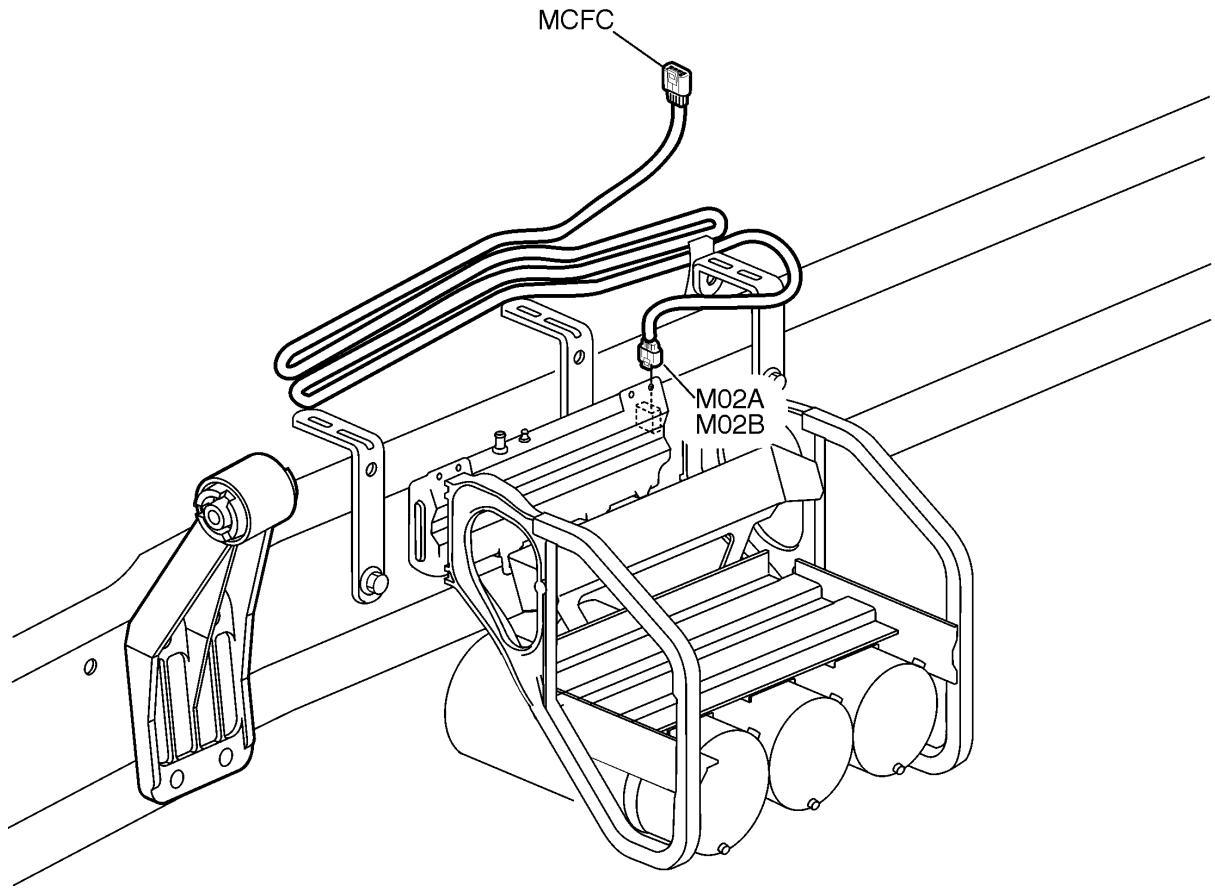

W3005935

Washer Reservoir, VHD

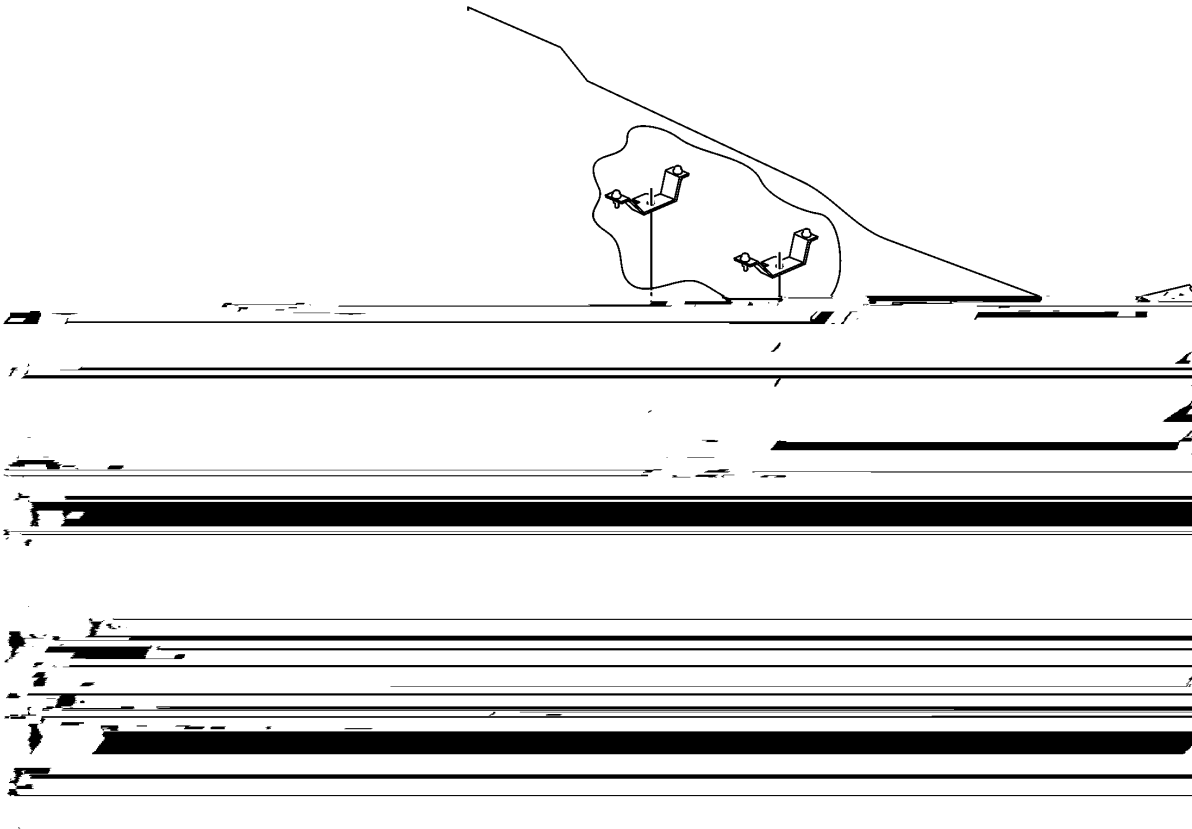
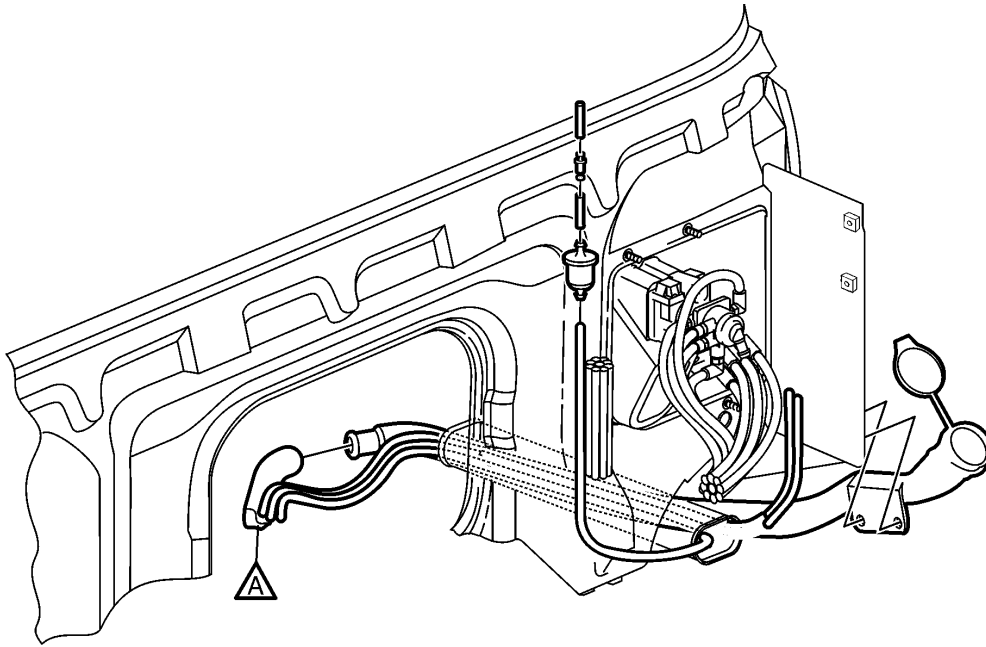

W3005910

Horn

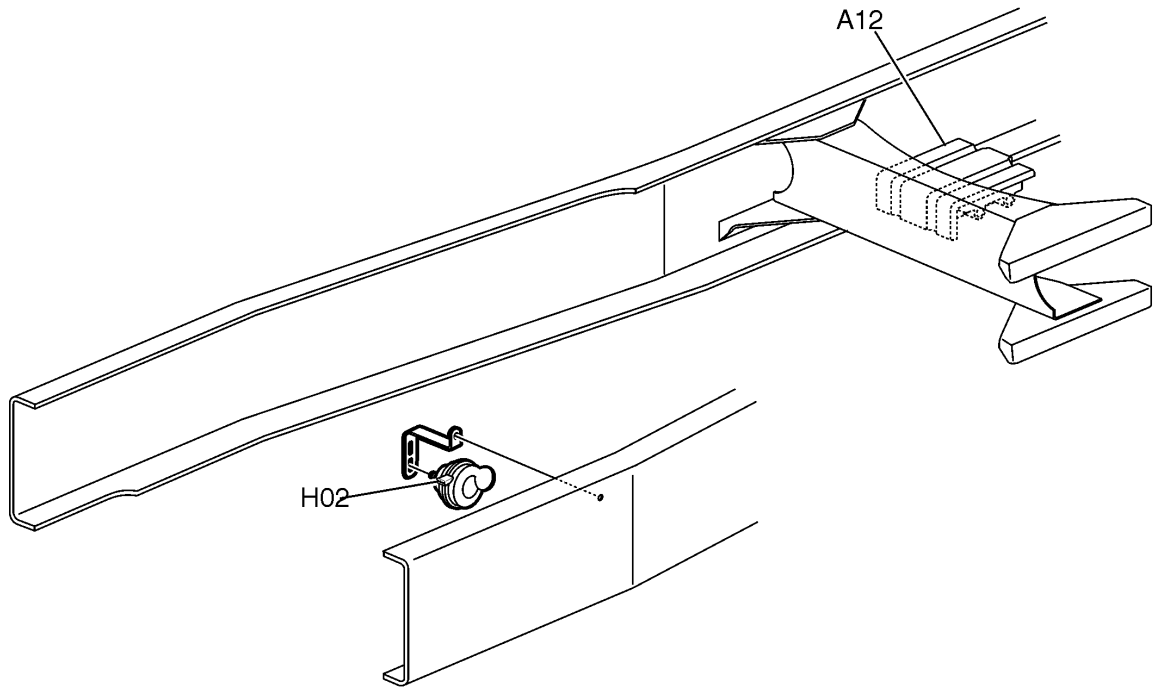

VN

VHD

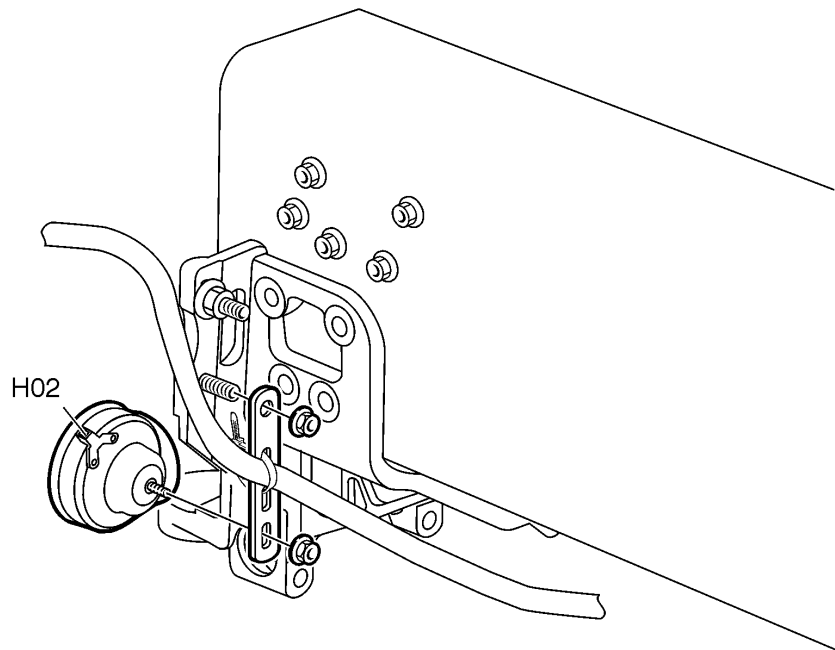

Fuel Level Sensor

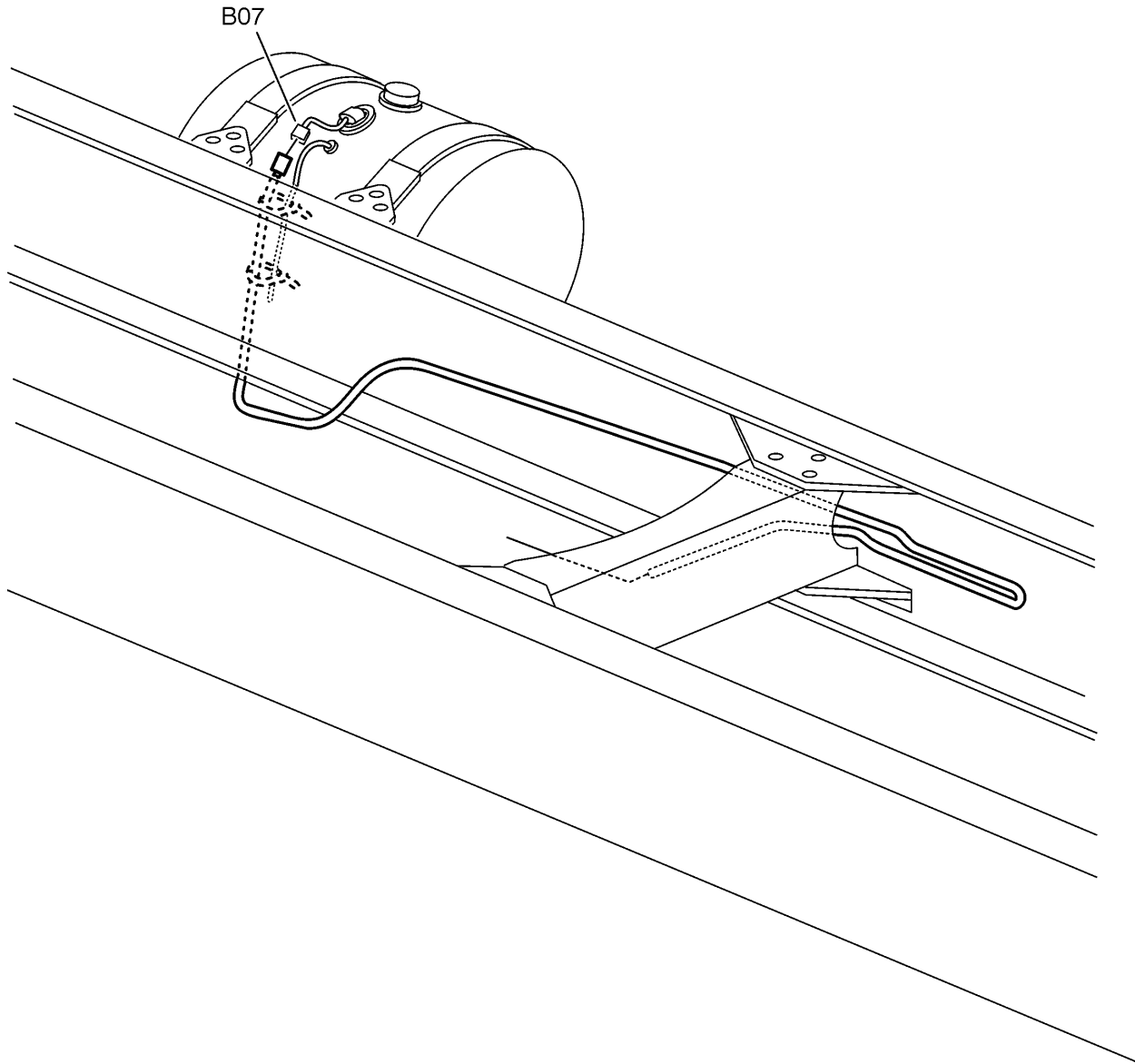
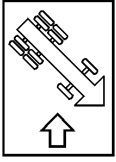

W3005909

Differential Lock/Axle Temperature

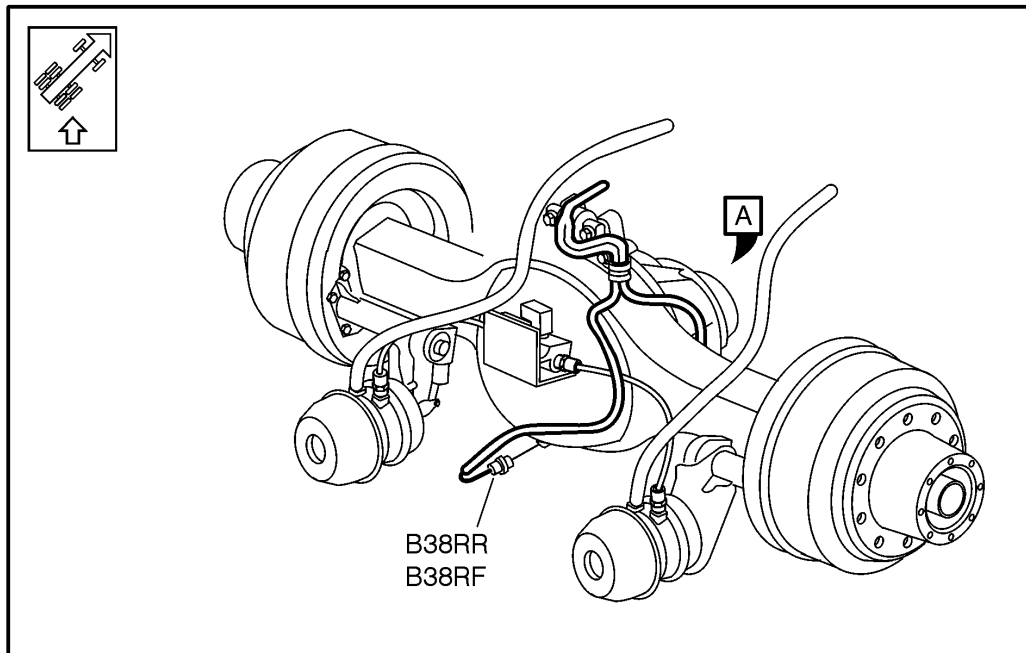
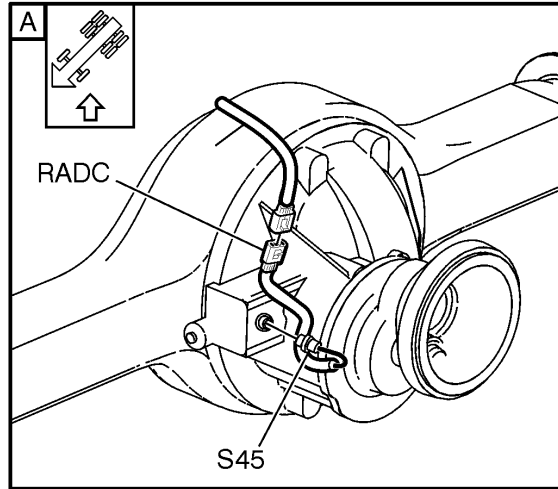

Central Tire Inflation System

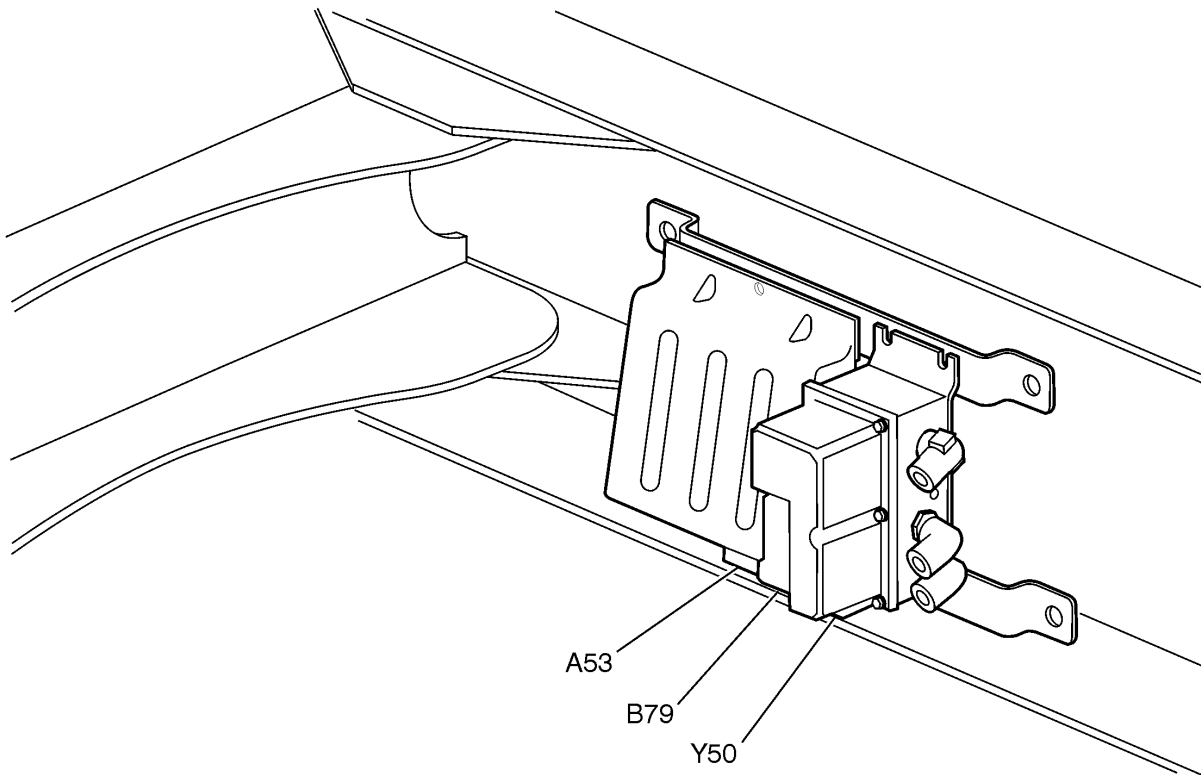

W3005930

Ambient Temperature Sensor

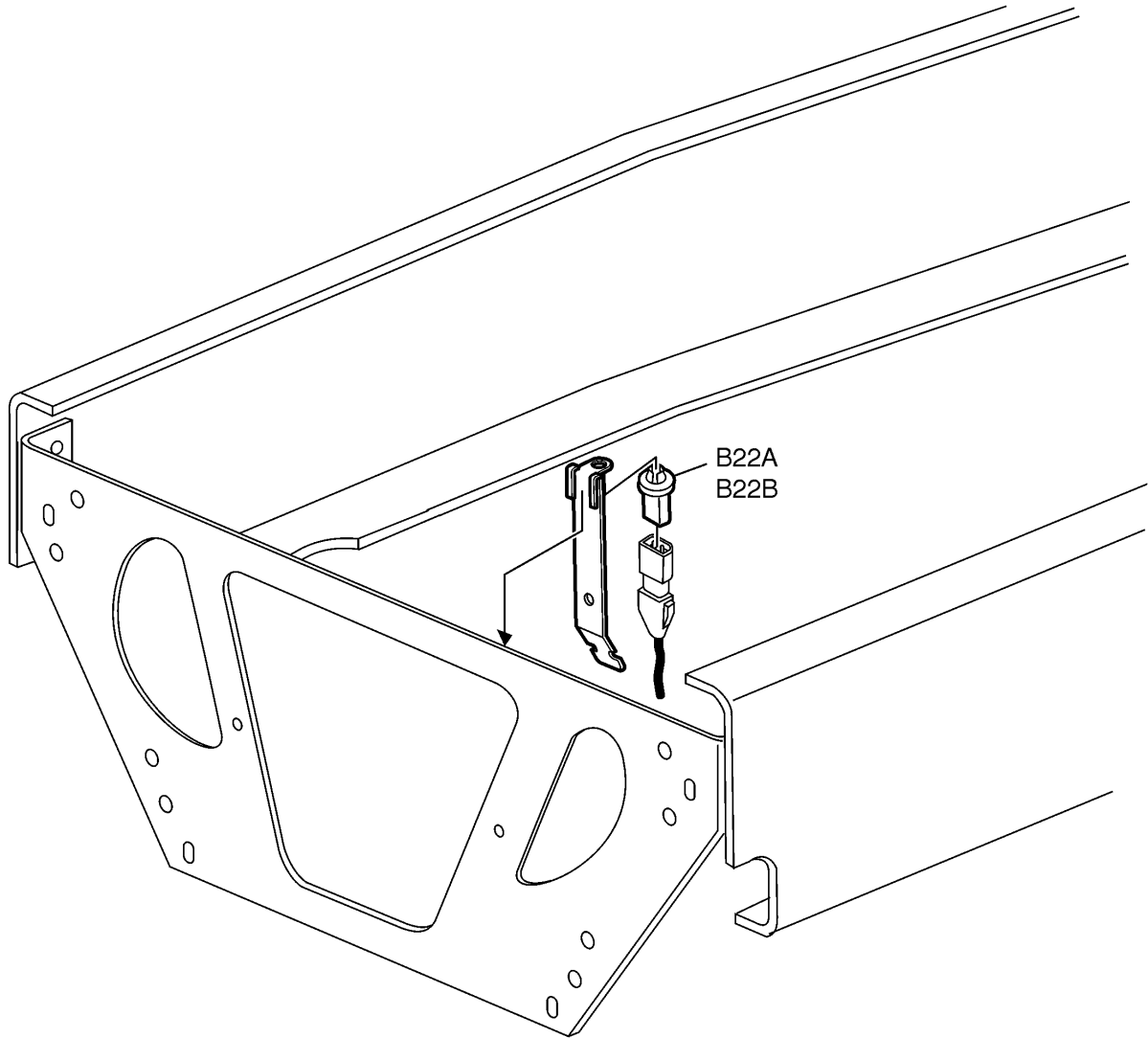

Pyrometer Sensor

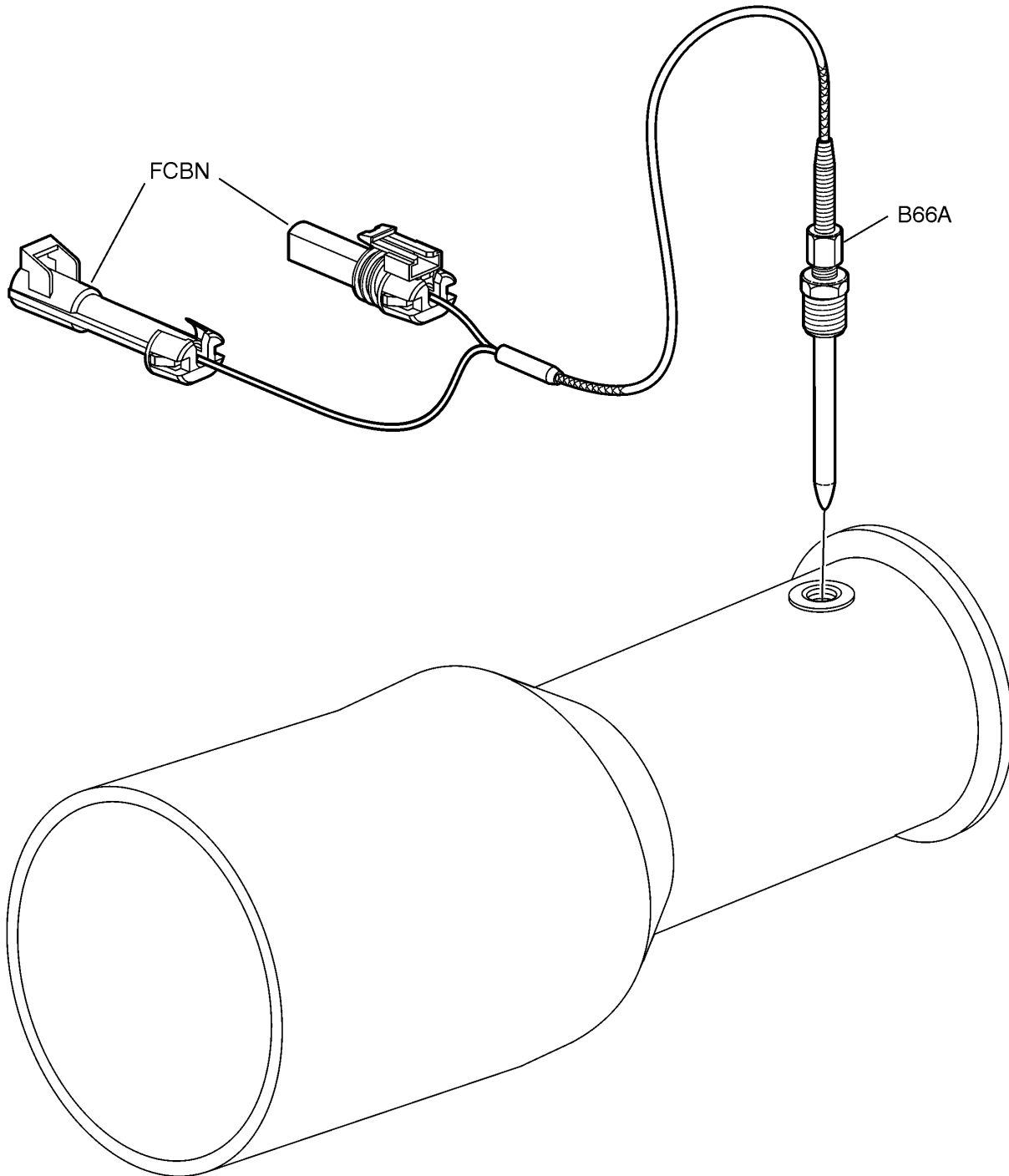
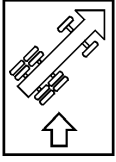

Chassis Harness

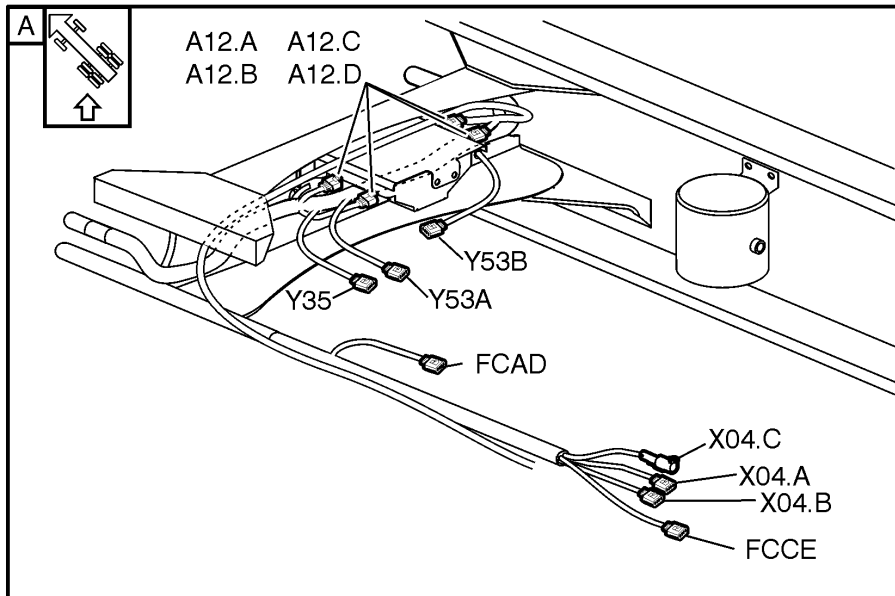
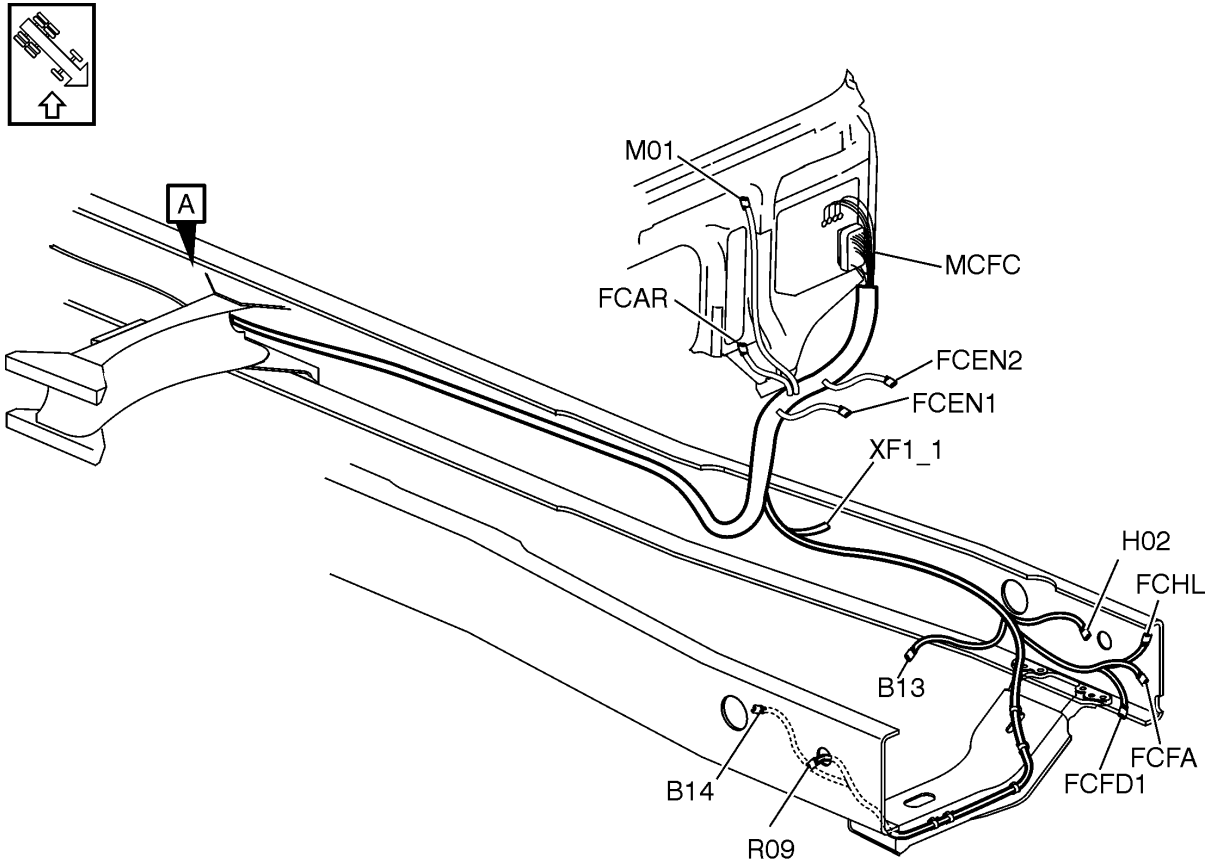

W3006519

VORAD Antennas

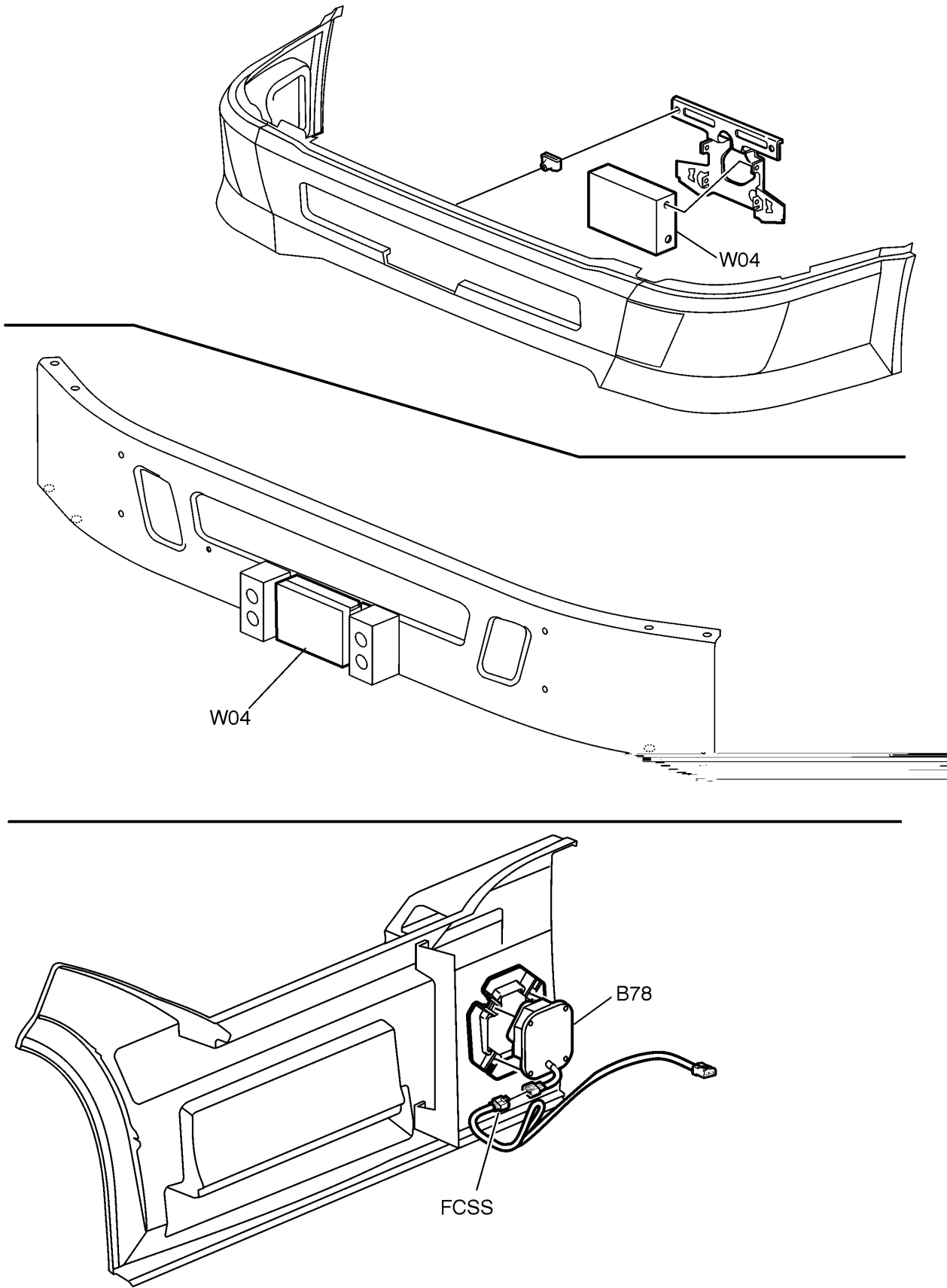

W3005938

Inverter

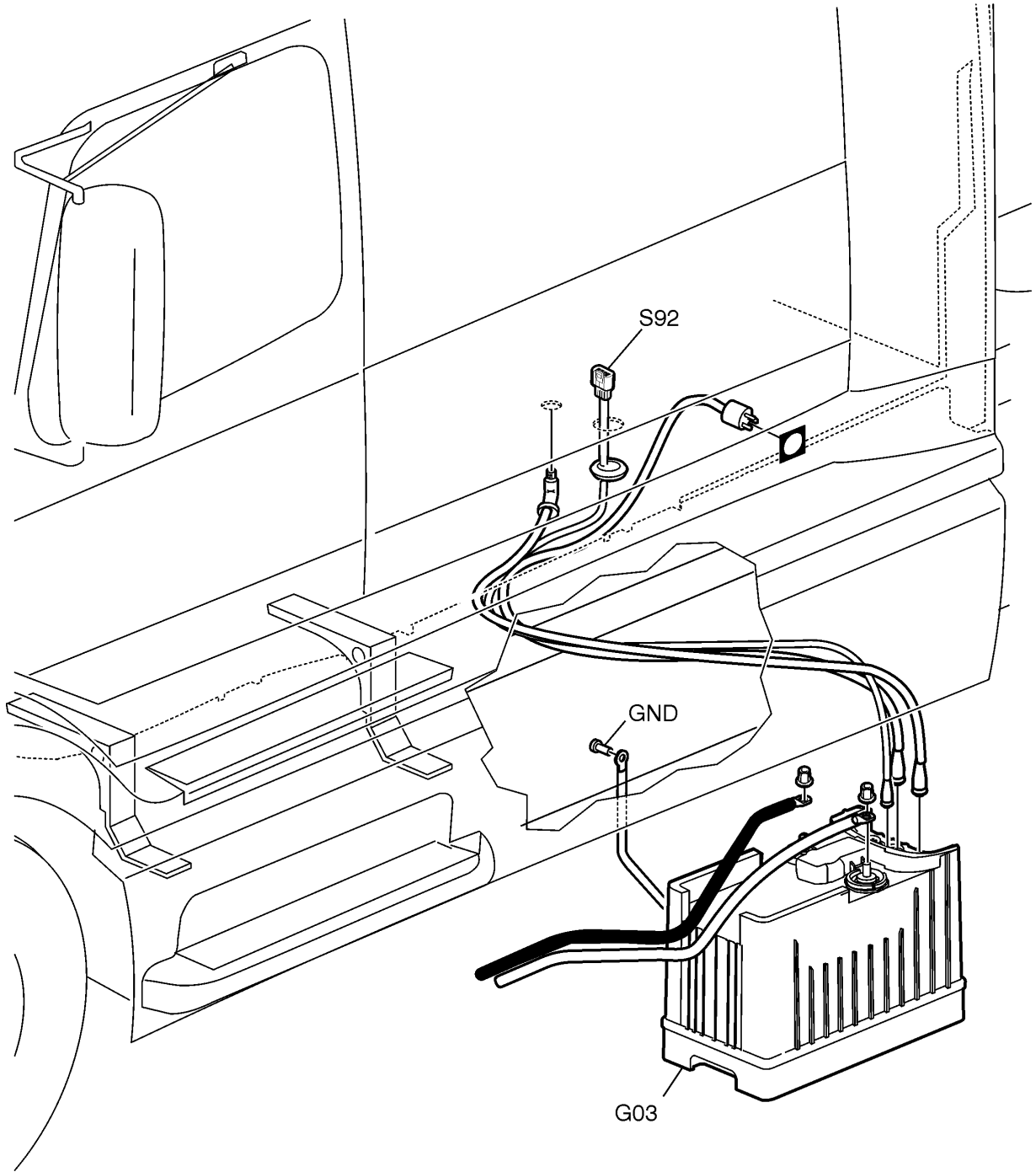

W3005916

Reference

Reference List: Fuses

Fuse	Circuit	Schematic
F1	DCP power /power mirror	{IC 2 A} Fig. 58: IC page 63 {AB 3 D} Fig. 2: AB page 7 {ID 3 A} Fig. 59: ID page 64
F2	Radio without Icon / Amp.	{KA 0 A} Fig. 66: KA page 71 {KB 2 A} Fig. 67: KB page 72 {KC 0 A} Fig. 68: KC page 73 {AB 3 D} Fig. 2: AB page 7
F3	Driver window/ heated mirrors	{IC 1 A} Fig. 58: IC page 63 {AB 3 D} Fig. 2: AB page 7 {ID 2 A} Fig. 59: ID page 64
F4	RH Window	{IC 3 A} Fig. 58: IC page 63 {AB 3 D} Fig. 2: AB page 7 {ID 1 A} Fig. 59: ID page 64
F5	Steering Wheel Module (SWM)	{JC 0 A} Fig. 65: JC page 70 {AB 3 D} Fig. 2: AB page 7
F6	Accessory expansion	{AB 4 D} Fig. 2: AB page 7
F7	Not Used	{AB 4 D} Fig. 2: AB page 7
F8	LCM1	{GB 2 A} Fig. 39: GB page 44 {AB 3 C} Fig. 2: AB page 7
F9	Trailer Marker Relay	{MA 0 A} Fig. 69: MA page 74 {AB 3 C} Fig. 2: AB page 7
F10	LCM2	{GB 2 B} Fig. 39: GB page 44 {AB 3 C} Fig. 2: AB page 7
F11	Battery Expansion/ Volvo Link	{BF 1 A} Fig. 10: BF page 15 {AB 3 C} Fig. 2: AB page 7 {BK 2 A} Fig. 15: BK page 20
F12	Road Relay/Battery Expansion	{BH 1 A} Fig. 12: BH page 17 {AB 4 C} Fig. 2: AB page 7
F13	Diagnostic Tool	{XA 2 A} Fig. 71: XA page 76 {AB 4 C} Fig. 2: AB page 7

Fuse	Circuit	Schematic
F14	Qualcom	{BE 0 B} Fig. 9: BE page 14 {AB 4 C} Fig. 2: AB page 7
F15	Key B+	{AB 1 B} Fig. 2: AB page 7
F16	Key 30	{AB 2 B} Fig. 2: AB page 7
F17	LCM3	{GB 3 A} Fig. 39: GB page 44 {AB 2 B} Fig. 2: AB page 7
F18	Trailer park relay	{GB 1 A} Fig. 39: GB page 44 {AB 2 B} Fig. 2: AB page 7
F19	Lightning transmission (battery)	{DC 0 A} Fig. 25: DC page 30 {AB 2 B} Fig. 2: AB page 7
F20	Battery protection / Beacon lamps	{HB 1 A} Fig. 50: HB page 55 {GI 3 A} Fig. 46: GI page 51 {AB 2 B} Fig. 2: AB page 7
F21	Cummins Engine DR	{CC 1 B} Fig. 18: CC page 23 {CI 3 B} Fig. 22: CI page 27
F22	Fuel filter	{AA 1 D} Fig. 1: AA page 6 {CE 0 A} Fig. 19: CE page 24
F23	Climate Control ignition	{AA 1 E} Fig. 1: AA page 6 {HA 0 B} Fig. 49: HA page 54
F24	Instrument cluster	{AA 2 E} Fig. 1: AA page 6 {BC 0 A} Fig. 7: BC page 12
F25	Heated seat	{AA 2 E} Fig. 1: AA page 6 {IB 1 A} Fig. 57: IB page 62
F26	Windshield wiper	{AA 2 E} Fig. 1: AA page 6 {GP 0 B} Fig. 47: GP page 52
F27	Interaxle Lock	{AA 2 E} Fig. 1: AA page 6 {FD 3 A} Fig. 36: FD page 41 {FC 2 A} Fig. 35: FC page 40
F28	Interwheel Lock	{AA 2 E} Fig. 1: AA page 6 {FD 1 A} Fig. 36: FD page 41 {FC 1 A} Fig. 35: FC page 40
F29	Camera Prep / Body Builder Ignition Z	{AA 3 D} Fig. 1: AA page 6 {BG 1 A} Fig. 11: BG page 16
F30	LH Power Seat	{AA 2 D} Fig. 1: AA page 6 {IB 0 A} Fig. 57: IB page 62

Fuse	Circuit	Schematic
F31	RH Power Seat	{AA 2 D} Fig. 1: AA page 6 {IB 1 A} Fig. 57: IB page 62
F32	Ignition Expansion	{AA 3 D} Fig. 1: AA page 6 {BJ 2 A} Fig. 14: BJ page 19 {BK 2 A} Fig. 15: BK page 20
F33	Snow plow lamps LH	{AA 3 D} Fig. 1: AA page 6 {GI 1 A} Fig. 46: GI page 51
F34	Central tire inflation	{AA 3 D} Fig. 1: AA page 6 {FE 1 A} Fig. 37: FE page 42
F35	Snow plow lamps RH	{AA 3 D} Fig. 1: AA page 6 {GI 1 A} Fig. 46: GI page 51
F36	Cigar 12V Outlet	{AA 0 D} Fig. 1: AA page 6 {IF 0 A} Fig. 61: IF page 66
F37	Dome/Door Lamps	{AA 0 D} Fig. 1: AA page 6 {IA 1 A} Fig. 56: IA page 61
F38	Not Used	{AA 0 D} Fig. 1: AA page 6
F39	CB	{AA 1 D} Fig. 1: AA page 6 {IF 3 A} Fig. 61: IF page 66
F40	ECS	{AA 1 D} Fig. 1: AA page 6 {EB 4 A} Fig. 32: EB page 37
F41	Air Horn	{AA 1 D} Fig. 1: AA page 6 {GQ 2 A} Fig. 48: GQ page 53
F42	LCM5	{AA 0 D} Fig. 1: AA page 6 {GB 3 B} Fig. 39: GB page 44
F43	Trailer Stop Relay	{AA 0 D} Fig. 1: AA page 6 {GB 2 A} Fig. 39: GB page 44
F44	LCM6	{AA 0 D} Fig. 1: AA page 6 {GB 3 A} Fig. 39: GB page 44
F45	City Horn	{AA 0 D} Fig. 1: AA page 6 {GQ 0 A} Fig. 48: GQ page 53
F46	Radio/Cluster Battery	{AA 1 D} Fig. 1: AA page 6 {BC 0 A} Fig. 7: BC page 12
F47	Climate Control	{AA 1 D} Fig. 1: AA page 6 {HA 0 A} Fig. 49: HA page 54
F48	Central Locks	{AA 1 D} Fig. 1: AA page 6 {IE 1 A} Fig. 60: IE page 65
F49	AUX1	{AA 0 E} Fig. 1: AA page 6 {NA 0 A} Fig. 70: NA page 75

Fuse	Circuit	Schematic
F50	AUX2	{AA 0 E} Fig. 1: AA page 6 {NA 1 A} Fig. 70: NA page 75
F51	AUX3	{AA 0 E} Fig. 1: AA page 6 {NA 2 B} Fig. 70: NA page 75
F52	Battery protection status	{AA 0 E} Fig. 1: AA page 6 {HB 1 A} Fig. 50: HB page 55
F53	12V Outlet Ovh.	{AA 1 E} Fig. 1: AA page 6 {IF 2 A} Fig. 61: IF page 66
F54	Battery expansion	{AA 1 E} Fig. 1: AA page 6 {GC 2 A} Fig. 40: GC page 45 {BK 2 A} Fig. 15: BK page 20
F55	-	
F56	Air dryer	{FA 2 A} Fig. 33: FA page 38 {AB 0 E} Fig. 2: AB page 7
F57	SRS	{JA 1 B} Fig. 63: JA page 68 {AB 0 E} Fig. 2: AB page 7
F58	Lift Axles / Body builder reverse	{FB 0 A} Fig. 34: FB page 39 {AB 0 E} Fig. 2: AB page 7
F59	Qualcomm / Inside/Outside Air	{BE 1 B} Fig. 9: BE page 14 {CH 2 A} Fig. 21: CH page 26 {AB 1 E} Fig. 2: AB page 7
F60	Road Relay / Body Builder Ign-Y/Ing. Exp.	{BG 1 A} Fig. 11: BG page 16 {BH 1 A} Fig. 12: BH page 17 {AB 1 E} Fig. 2: AB page 7
F61	ABS1	{EA 2 A} Fig. 31: EA page 36 {AB 1 E} Fig. 2: AB page 7
F62	ABS2	{EA 2 A} Fig. 31: EA page 36 {AB 1 E} Fig. 2: AB page 7
F63	Susp. Dump	{FD 2 A} Fig. 36: FD page 41 {FB 4 A} Fig. 34: FB page 39 {AB 2 E} Fig. 2: AB page 7
F64	5th Wheel Slide	{FD 3 A} Fig. 36: FD page 41 {FB 3 A} Fig. 34: FB page 39 {AB 2 E} Fig. 2: AB page 7

Fuse	Circuit	Schematic
F65	Light Control Module / Light Control Panel	{GA 1 A} Fig. 38: GA page 43 {AB 2 E} Fig. 2: AB page 7
F66	Body Builder Ign-X	{BG 0 A} Fig. 11: BG page 16 {AB 2 E} Fig. 2: AB page 7
F67	VED16 Coolant Pump	{AB 3 E} Fig. 2: AB page 7
F68	Central lock Ign.	{IE 1 A} Fig. 60: IE page 65 {AB 3 E} Fig. 2: AB page 7
F69	Ign Expansion/ Volvo Link	{BF 1 A} Fig. 10: BF page 15 {AB 3 E} Fig. 2: AB page 7
F70	Vorad/ECS	{AA 2 D} Fig. 1: AA page 6 {JB 2 A} Fig. 64: JB page 69 {EB 3 A} Fig. 32: EB page 37
F71	DR Spare	{AA 2 D} Fig. 1: AA page 6
F72	Gearbox	{AA 3 D} Fig. 1: AA page 6 {DB 0 A} Fig. 24: DB page 29 {DC 0 A} Fig. 25: DC page 30 {DD 1 A} Fig. 26: DD page 31 {DG 1 A} Fig. 29: DG page 34 {DF 1 B} Fig. 28: DF page 33
F73	ICON	{AA 3 D} Fig. 1: AA page 6
F74	Radio with Icon / Amp.	{AA 3 D} Fig. 1: AA page 6
F75	PTO/ Dual PTO	{AA 3 D} Fig. 1: AA page 6 {DP 2 A} Fig. 30: DP page 35
F76	Engine Brake	{AA 3 D} Fig. 1: AA page 6 {CF 2 A} Fig. 20: CF page 25
F77	Allison DR	{DF 3 B} Fig. 28: DF page 33
F78	Allison Battery	{DF 0 B} Fig. 28: DF page 33
F79	EMS A	{BA 0 A} Fig. 5: BA page 10
F80	EMS B/ Deairation Sw.	{BA 1 A} Fig. 5: BA page 10
F81	EMS System/VECU	{BA 0 A} Fig. 5: BA page 10
F82	Body Builder module	{BA 0 A} Fig. 5: BA page 10
F90	Fuel Sink pump	{HE 0 C} Fig. 53: HE page 58
F91	Not used	

Fuse	Circuit	Schematic
F92	Interior Lamps	{HF 2 B} Fig. 54: HF page 59
FB01	FUSE, BATTERY 1, EMS	{BA 0 D} Fig. 5: BA page 10
FB02	FUSE, BATTERY 2, EMS	{CC 2 C} Fig. 18: CC page 23 {CI 1 B} Fig. 22: CI page 27
FB03	FUSE, BATTERY 1 TRANSMISSION	{DB 4 B} Fig. 24: DB page 29 {DG 0 C} Fig. 29: DG page 34 {DF 3 D} Fig. 28: DF page 33
FB04	FUSE, BATTERY 2 TRANSMISSION	{DF 3 D} Fig. 28: DF page 33

Reference List: Relays

Relay	Circuit	Schematic
RLY01	RELAY, DR	{AA 3 C} Fig. 1: AA page 6
RLY02	RELAY, TRAILER PARKING	{GB 1 B} Fig. 39: GB page 44
RLY03	RELAY, TRAILER STOP	{GB 2 B} Fig. 39: GB page 44
RLY04	RELAY, EMS	{BA 0 B} Fig. 5: BA page 10
RLY05	RELAY, LIFT AXLE / REVERSE SIGNAL	{FB 3 B} Fig. 34: FB page 39
RLY07	RELAY, PTO	{DP 1 B} Fig. 30: DP page 35
RLY08	RELAY, ICON PARK BRAKE INPUT	{CC 3 B} Fig. 18: CC page 23
RLY09	RELAY TRAILER MARKER	{MA 0 B} Fig. 69: MA page 74
RLY10	RELAY, CITY HORN	{GQ 0 C} Fig. 48: GQ page 53
RLY11	RELAY, DOME / DOOR LAMPS	{IE 1 C} Fig. 60: IE page 65
RLY12	RELAY, INTERMITTENT WIPER	{GP 0 B} Fig. 47: GP page 52
RLY13	RELAY, AUTOSHIFT	{DB 1 B} Fig. 24: DB page 29
RLY13_1	RELAY, ALLISON START ENABLE	{DF 0 B} Fig. 28: DF page 33
RLY14	RELAY, ALLISON AUTONEUTRAL	{DF 1 B} Fig. 28: DF page 33
RLY15	RELAY, ALLISON POWER	{DF 1 B} Fig. 28: DF page 33
RLY16	RELAY, BODY BUILDER REMOTE THROTTLE INC	{BA 3 C} Fig. 5: BA page 10
RLY17	RELAY, BODY BUILDER REMOTE THROTTLE DEC	{BA 3 B} Fig. 5: BA page 10
RLY18	RELAY, ALLISON SERVICE BRAKE INPUT	{DF 2 B} Fig. 28: DF page 33
RLY20	RELAY, ALLISON BODY BUILDERER1	{DF 2 B} Fig. 28: DF page 33
RLY21	RELAY, ALLISON BODY BUILDERER2	{DF 3 B} Fig. 28: DF page 33
RLY26	SNOWPLOW LH ER8	{GI 1 C} Fig. 46: GI page 51
RLY27	SNOWPLOW RH ER9	{GI 0 C} Fig. 46: GI page 51
RLY28	SNOWPLOW LCM INPUTER7	{GI 2 C} Fig. 46: GI page 51
RLY29	POWER RELAY 1 BATTERY	{AA 1 C} Fig. 1: AA page 6
RLY30	POWER RELAY 2 IGNITION	{AA 1 C} Fig. 1: AA page 6
RLY31	POWER RELAY 3 IGNITION	{AB 1 D} Fig. 2: AB page 7
RLY32	POWER RELAY 4 ACCESSORY	{AB 1 D} Fig. 2: AB page 7
RLY33	Relay, ER9 Motorized Mirror	{ID 3 C} Fig. 59: ID page 64
RLY34	ER8 ECS Power	{EB 3 B} Fig. 32: EB page 37
RLY35	MEIIR ER3	{DB 3 B} Fig. 24: DB page 29 {DB 2 B} Fig. 24: DB page 29
RLY36	Relay, ER7 Power Window "UP"	{ID 1 C} Fig. 59: ID page 64
RLY37	Relay, ER6 Power Window "DOWN"	{ID 0 C} Fig. 59: ID page 64
RLY38	Roof Marker Lamps ER2	{GC 2 B} Fig. 40: GC page 45
RLY39	Relay Sleeper HVAC On Harness	{HG 3 B} Fig. 55: HG page 60
RLY40	RELAY STARTER MOTOR	{AD 0 C} Fig. 4: AD page 9 {AD 1 B} Fig. 4: AD page 9
RLY41	RELAY, PARK BRAKE	{HB 4 C} Fig. 50: HB page 55
RLY42	RELAY ENGINE PREHEAT	{CB 2 B} Fig. 17: CB page 22
RLY43	Relay, Shunt	{AA 0 C} Fig. 1: AA page 6
RLY44	Relay, Battery Protection ER8	{HB 1 D} Fig. 50: HB page 55

Reference List: Components

Component # and Description		Location
A03A	INSTRUMENT CLUSTER A	{BC 0 C} Fig. 7: BC page 12
A03B	INSTRUMENT CLUSTER B	{BC 2 C} Fig. 7: BC page 12
A03C	INSTRUMENT CLUSTER C	{BD 0 C} Fig. 7: BC page 12
A03S	Secondary Gauges	{BK 1 B} Fig. 15: BK page 20
A04	REFRIGERATOR	{HD 0 B} Fig. 52: HD page 57 {HE 1 C} Fig. 53: HE page 58
A04A	REFRIGERATOR	{HE 1 D} Fig. 53: HE page 58
A07A	RADIO	{KA 0 C} Fig. 66: KA page 71
A07B	RADIO	{KB 2 B} Fig. 67: KB page 72
A07C	RADIO	{KC 1 B} Fig. 68: KC page 73
A07D	RADIO	{JC 1 C} Fig. 65: JC page 70
A08	Control unit, GPS receiver, (Global Positioning System)	{BF 1 C} Fig. 10: BF page 15
A12	Control unit, ABS (Anti-lock Brake System)	{EA 2 C} Fig. 31: EA page 36
A13L	CONTROL UNIT LIGHTNING TRANSMISSION	{DC 0 C} Fig. 25: DC page 30
A13M	CONTROL UNIT MERITOR TRANSMISSION	{DD 1 C} Fig. 26: DD page 31
A14A	CONTROL UNIT, EMS (Engine Management System)	{CO 0 C} Fig. 17: CB page 22
A14B	CONTROL UNIT, EMS, CUMMINS ISX	{CC 0 D} Fig. 18: CC page 23
A14E	CONTROL UNIT, ISX 2000 W/O ICON	{CI 1 D} Fig. 22: CI page 27
A15	Control unit, SRS (Supplementary Restrain System)	{JA 1 C} Fig. 63: JA page 68
A07C	RADIO	{KC 1 B} Fig. 68: KC page 73
A16	Control unit, ECS (Electronic Controlled Air Suspension)	{EB 0 C} Fig. 32: EB page 37

Component # and Description		Location
A17	Control unit, VECU (Vehicle ECU)	{BA 1 D} Fig. 5: BA page 10 {BB 0 A} Fig. 6: BB page 11 {CF 3 E} Fig. 20: CF page 25 {CF 3 C} Fig. 20: CF page 25 {CF 3 E} Fig. 20: CF page 25 {CF 2 C} Fig. 20: CF page 25 {CF 1 C} Fig. 20: CF page 25
A19D	CONTROL UNIT, GECU (GEAR SELECTOR ECU) ALLISON TRANSMISSION	{DE 1 B} Fig. 27: DE page 32
A27	LIGHT CONTROL MODULE	{GA 3 C} Fig. 38: GA page 43 {GG 0 A} Fig. 44: GG page 49 {GB 0 C} Fig. 39: GB page 44
A30	CONTROL UNIT, SWC (STEERING WHEEL CONTROL)	{JC 1 C} Fig. 65: JC page 70
A34	Control unit, climate unit	{HA 2 B} Fig. 49: HA page 54
A35	Control unit, remote receiver, door lock	{IE 3 B} Fig. 60: IE page 65
A36	Control unit, BBM (Body Builder Module)	{BI 0 C} Fig. 13: BI page 18
A38	Control unit, FMS, satellite communication	{BE 1 C} Fig. 9: BE page 14
A43	Electronic Fan Control (Including B32, Y35)	{CO 4 B} Fig. 23: CO page 28
A44	Fuel Filter Bracket (Including M15, B51)	{CO 2 B} Fig. 23: CO page 28
A46	Control unit, LECM (Living Environment Control Module)	{HD 3 A} Fig. 52: HD page 57 {HB 3 B} Fig. 50: HB page 55 {HE 2 A} Fig. 53: HE page 58
A48	TV	{KC 0 C} Fig. 68: KC page 73
A50	CPU, Vorad	{JB 2 C} Fig. 64: JB page 69
A51	Display, Side Sensor Vorad	{JB 1 E} Fig. 64: JB page 69
A52	Display, CTI (Central Tire Inflation)	{FE 2 B} Fig. 37: FE page 42
A53	Control unit, CTI (Central Tire Inflation)	{FE 0 C} Fig. 37: FE page 42
A54	Control Unit, Coolant Level	{CC 0 E} Fig. 18: CC page 23 {CI 0 D} Fig. 22: CI page 27

Component # and Description		Location
A55	AUTOSHIFT II TRANSMISSION	{DB 3 D} Fig. 24: DB page 29
A56	Stereo amplifier	{KC 0 C} Fig. 68: KC page 73
A57	CONTROL UNIT, ALLISON TRANSMISSION	{DE 3 C} Fig. 27: DE page 32 {DF 0 D} Fig. 28: DF page 33
A58	ALLISON TRANSMISSION	{DE 0 E} Fig. 27: DE page 32
A66	DISPLAY, AUTOSHIFT	{DB 1 C} Fig. 24: DB page 29
A67	DISPLAY DRIVER VORAD	{JB 0 A} Fig. 64: JB page 69
A68	MERITOR FREEDOMLINE	{DG 0 E} Fig. 29: DG page 34
A69	SHIFT MODULE	{DG 1 B} Fig. 29: DG page 34
A70	Shift module Autoshift II	{DB 0 D} Fig. 24: DB page 29
B02A	THERMOSTAT, SLEEPER CONTROL #1	{HG 2 B} Fig. 55: HG page 60
B04	Sensor, engine speed, crankshaft	{CO 1 D} Fig. 23: CO page 28
B05	Sensor, engine speed, camshaft	{CO 1 D} Fig. 23: CO page 28
B06A	SENSOR AIR PRESSURE TANK A	{BC 3 D} Fig. 7: BC page 12
B06AP	SENSOR AIR PRESSURE BRAKE APPLICATION	{BC 2 D} Fig. 7: BC page 12
B06B	SENSOR AIR PRESSURE TANK B	{BC 3 D} Fig. 7: BC page 12
B07	SENSOR FUEL LEVEL	{BC 2 D} Fig. 7: BC page 12
B08	Sensor, gearbox speed	{FE 1 D} Fig. 37: FE page 42
B09	SENSOR OIL TEMP GEARBOX	{BC 4 B} Fig. 7: BC page 12
B10	Sensor, oil level	{CO 1 D} Fig. 23: CO page 28
B13	Sensor, wheel speed, lhs. 1:st front axle	{EA 1 B} Fig. 31: EA page 36
B14	Sensor, wheel speed, rhs. 1:st front axle	{EA 1 B} Fig. 31: EA page 36
B15	Sensor, wheel speed, lhs. 1:st driven rear axle	{EA 0 D} Fig. 31: EA page 36
B16	Sensor, wheel speed, rhs. 1:st driven rear axle	{EA 0 D} Fig. 31: EA page 36
B17	Sensor, wheel speed, lhs., 2:nd driven rear axle	{EA 2 D} Fig. 31: EA page 36

Component # and Description		Location
B18	Sensor, wheel speed, rhs., 2:nd driven rear axle	{EA 3 D} Fig. 31: EA page 36
B21	Sensor, coolant temperature, engine	{CO 0 B} Fig. 23: CO page 28
B22B	SENSOR AMBIENT AIR TEMP.	{BC 3 A} Fig. 7: BC page 12
B25	Sensor, accelerator pedal	{BB 4 C} Fig. 6: BB page 11
B30A	Sensor, chassis level, drive axle	{EB 2 D} Fig. 32: EB page 37
B32	Sensor, engine cooling, fan speed	{CO 4 B} Fig. 23: CO page 28
B37	Sensor, boost pressure and boost temperature	{CO 0 D} Fig. 23: CO page 28
B38	Sensor, oil pressure and oil temperature	{CO 0 D} Fig. 23: CO page 28
B38RF	SENSOR OIL TEMP REAR FRONT AXLE	{BC 3 B} Fig. 7: BC page 12
B38RR	SENSOR OIL TEMP REAR REAR AXLE	{BC 3 B} Fig. 7: BC page 12
B39	SENSOR AIR RESTRICTION	{BD 1 B} Fig. 8: BD page 13
B51	Sensor, fuel pressure	{CO 2 B} Fig. 23: CO page 28
B54	Sensor, crank case pressure	{CO 1 B} Fig. 23: CO page 28
B55A	Sensor, Air Pressure, Suspension	{EB 0 D} Fig. 32: EB page 37
B56	Sensor, Air Pressure, Suspension Spring, Front Axle	{BC 2 B} Fig. 7: BC page 12
B58A	Sensor, Air Pressure, Suspension Spring, Drive Axle	{EB 1 D} Fig. 32: EB page 37
B58R	Sensor, Air Pressure, Rear Suspension	{BC 2 D} Fig. 7: BC page 12
B59	Sensor, Indoor Temp.	{HA 2 B} Fig. 49: HA page 54
B60A	SPEAKER LEFT DASH	{KA 2 D} Fig. 66: KA page 71 {KB 3 D} Fig. 67: KB page 72 {KC 1 D} Fig. 68: KC page 73
B60B	SPEAKER RIGHT DASH	{KA 2 D} Fig. 66: KA page 71 {KB 2 D} Fig. 67: KB page 72 {KC 2 D} Fig. 68: KC page 73

Component # and Description		Location
B60C	SPEAKER LEFT DOOR	{KA 0 D} Fig. 66: KA page 71 {KB 3 D} Fig. 67: KB page 72 {KC 0 D} Fig. 68: KC page 73
B60D	SPEAKER RIGHT DOOR	{KA 1 D} Fig. 66: KA page 71 {KB 2 D} Fig. 67: KB page 72 {KC 0 D} Fig. 68: KC page 73
B60E	SPEAKER LEFT UPPER	{KB 0 D} Fig. 67: KB page 72 {KC 2 B} Fig. 68: KC page 73
B60F	SPEAKER RIGHT UPPER	{KB 0 D} Fig. 67: KB page 72 {KC 3 B} Fig. 68: KC page 73
B60G	SPEAKER LEFT LOWER	{KC 2 D} Fig. 68: KC page 73
B60H	SPEAKER RIGHT LOWER	{KC 2 D} Fig. 68: KC page 73
B60I	SPEAKER SUBWOOFER	{KC 3 D} Fig. 68: KC page 73
B60J	SPEAKER LEFT UPPER	{KB 1 D} Fig. 67: KB page 72
B60K	SPEAKER RIGHT UPPER	{KB 1 D} Fig. 67: KB page 72
B60L	SPEAKER LEFT REAR	{KB 0 B} Fig. 67: KB page 72
B60M		{KB 0 B} Fig. 67: KB page 72

Component # and Description		Location
B68A	Sensor, Output shaft Speed, gearbox	{BB 1 D} Fig. 6: BB page 11
B68B	Sensor, Output shaft Speed, gearbox	{DC 1 D} Fig. 25: DC page 30
B68C	Sensor Output Shaft Speed, Gearbox	{CC 1 C} Fig. 18: CC page 23 {CI 2 C} Fig. 22: CI page 27
B78	Side Sensor, Vorad	{JB 1 E} Fig. 64: JB page 69
B79	Sensor, PCU (Pneumatic Control Unit)	{FE 2 D} Fig. 37: FE page 42
B80	SENSOR, ETHER START	{CA 1 B} Fig. 16: CA page 21
B103	Sensor, Transmission Turbine Speed	{DE 2 D} Fig. 27: DE page 32
B104	Sensor, Output Speed	{DE 3 D} Fig. 27: DE page 32
B105	Sensor Retarder Temp.	{DE 2 D} Fig. 27: DE page 32
E05A	LAMP 5TH WHEEL (L1)	{GG 1 C} Fig. 44: GG page 49
E05B	LAMP 5TH WHEEL (L3, L4)	{GH 0 C} Fig. 45: GH page 50
E05C	LAMP 5TH WHEEL (L5)	{GH 2 C} Fig. 45: GH page 50
E05D	LAMP 5TH WHEEL	{GG 2 C} Fig. 44: GG page 49 {GG 1 C} Fig. 44: GG page 49 {GH 0 C} Fig. 45: GH page 50 {GH 3 C} Fig. 45: GH page 50 {GH 2 C} Fig. 45: GH page 50 {GH 3 C} Fig. 45: GH page 50 {GH 1 C} Fig. 45: GH page 50
E05E	LAMP 5TH WHEEL	{GG 1 C} Fig. 44: GG page 49 {GH 0 C} Fig. 45: GH page 50 {GH 2 C} Fig. 45: GH page 50
E05F	LAMP 5TH WHEEL	{GG 2 C} Fig. 44: GG page 49 {GH 3 C} Fig. 45: GH page 50 {GH 1 C} Fig. 45: GH page 50
E05G	LAMP 5TH WHEEL	{GG 2 C} Fig. 44: GG page 49 {GH 3 C} Fig. 45: GH page 50 {GH 1 C} Fig. 45: GH page 50

Component # and Description		Location
E05H	LAMP 5TH WHEEL	{GG 2 C} Fig. 44: GG page 49 {GH 2 C} Fig. 45: GH page 50 {GH 3 C} Fig. 45: GH page 50
E06	Lamp, Backup	{GF 1 B} Fig. 43: GF page 48 {GF 3 C} Fig. 43: GF page 48
E07L	Lamp, Fog Light	{GE 1 C} Fig. 42: GE page 47
E07R	Lamp, Fog Light	{GE 1 C} Fig. 42: GE page 47
E08L	Lamp, Driving Light	{GE 2 C} Fig. 42: GE page 47
E08R	Lamp, Driving Light	{GE 2 C} Fig. 42: GE page 47
E10	Lamp, Tail Light	{GF 3 D} Fig. 43: GF page 48
E10L	LAMP TAIL LIGHT LEFT	{GF 0 D} Fig. 43: GF page 48
E10LA	LAMP TAIL LIGHT LEFT	{GF 1 B} Fig. 43: GF page 48
E10LB	LAMP TAIL LIGHT LEFT	{GF 2 C} Fig. 43: GF page 48
E10R	LAMP TAIL LIGHT RIGHT	{GF 1 D} Fig. 43: GF page 48
E10RA	LAMP TAIL LIGHT RIGHT	{GF 1 B} Fig. 43: GF page 48
E10RB	LAMP TAIL LIGHT RIGHT	{GF 3 C} Fig. 43: GF page 48
E11L	Lamp, Side Repeater	{GA 1 D} Fig. 38: GA page 43
E11R	Lamp, Side Repeater	{GA 1 D} Fig. 38: GA page 43
E12A	LAMP, MARKER	{GC 1 C} Fig. 40: GC page 45
E12B	LAMP, MARKER	{GC 1 C} Fig. 40: GC page 45
E12C	LAMP, MARKER	{GC 2 C} Fig. 40: GC page 45
E12D	LAMP, MARKER	{GC 2 C} Fig. 40: GC page 45
E12E	LAMP, MARKER	{GC 2 C} Fig. 40: GC page 45
E13L	Lamp, Park/Turn	{GD 0 C} Fig. 41: GD page 46
E13R	Lamp, Park/Turn	{GD 0 C} Fig. 41: GD page 46
E14L	WARNING LAMP SNOWPLOW	{GI 3 C} Fig. 46: GI page 51

Component # and Description		Location
E14R	WARNING LAMP SNOWFLOW	{GI 4 C} Fig. 46: GI page 51
E16L	Lamp Door, D.S.	{IA 1 D} Fig. 56: IA page 61
E16R	Lamp Door, P.S.	{IA 1 D} Fig. 56: IA page 61
E17C	Lamp Fluorescent	{HD 2 C} Fig. 52: HD page 57 {HE 3 C} Fig. 53: HE page 58
E17D	Lamp Workcenter Fluorescent	{HE 3 B} Fig. 53: HE page 58
E17L	Lamp, Interior Light	{IA 1 D} Fig. 56: IA page 61
E17R	Lamp, Interior Light	{IA 0 D} Fig. 56: IA page 61
E18A	Lamp Lower D.S.	{HD 4 D} Fig. 52: HD page 57
E18B	Lamp Under Cabinet D.S.	{HD 3 C} Fig. 52: HD page 57
E18C	Lamp Upper D.S.	{HD 1 C} Fig. 52: HD page 57 {HE 2 B} Fig. 53: HE page 58
E18D	Lamp Upper P.S.	{HE 2 B} Fig. 53: HE page 58
E18E	Lamp Valance D.S.	{HE 3 C} Fig. 53: HE page 58
E18F	Lamp Valance P.S.	{HE 3 B} Fig. 53: HE page 58
E18G	Lamp Upper P.S.	{HD 2 C} Fig. 52: HD page 57 {HF 2 C} Fig. 54: HF page 59
E18H	Lamp Upper D.S.	{HD 2 C} Fig. 52: HD page 57 {HF 2 C} Fig. 54: HF page 59
E18J	Lamp Lower D.S.	{HD 3 D} Fig. 52: HD page 57
E18K	Lamp Table	{HD 3 D} Fig. 52: HD page 57
E20A	Lamp Ashtray Illumination	{IF 1 C} Fig. 61: IF page 66
E22A	LAMP, ROOF SIGN ILLUMINATION	{GC 0 C} Fig. 40: GC page 45
E22B	LAMP, ROOF SIGN ILLUMINATION	{GC 0 C} Fig. 40: GC page 45
E22C	LAMP, ROOF SIGN ILLUMINATION	{GC 0 C} Fig. 40: GC page 45
E23A	Lamp Luggage D.S.	{HD 3 B} Fig. 52: HD page 57 {HF 3 C} Fig. 54: HF page 59
E23B	Lamp Luggage P.S.	{HD 3 B} Fig. 52: HD page 57 {HF 3 C} Fig. 54: HF page 59
E23C	Lamp Luggage D.S.	{HE 3 D} Fig. 53: HE page 58

Component # and Description		Location
E23D	Lamp Luggage P.S.	{HE 4 D} Fig. 53: HE page 58
E26L	Lamp, Headlamp Module	{GD 1 C} Fig. 41: GD page 46
E26L_1	Lamp, Headlamp Module	{GD 3 C} Fig. 41: GD page 46
E26R	Lamp, Headlamp Module	{GD 2 C} Fig. 41: GD page 46
E26R_1	Lamp, Headlamp Module	{GD 4 C} Fig. 41: GD page 46
E28	PARKING HEATER	{HB 3 D} Fig. 50: HB page 55
E30L	Lamp, Headlamp	{GD 0 C} Fig. 41: GD page 46
E30R	Lamp, Headlamp	{GD 1 C} Fig. 41: GD page 46
E32	HVAC UNIT	{HB 2 C} Fig. 50: HB page 55 {HG 2 C} Fig. 55: HG page 60
E32A	HVAC UNIT	{HA 2 D} Fig. 49: HA page 54
E36A	LAMP, SUNVISOR	{GC 3 C} Fig. 40: GC page 45
E36B	LAMP, SUNVISOR	{GC 3 C} Fig. 40: GC page 45
E36C	LAMP, SUNVISOR	{GC 3 C} Fig. 40: GC page 45
E36D	LAMP, SUNVISOR	{GC 3 C} Fig. 40: GC page 45
E36E	LAMP, SUNVISOR	{GC 4 C} Fig. 40: GC page 45
E37	Lamp LECM Panel	{HE 1 B} Fig. 53: HE page 58
E39	Lamp, License Plate Illumination	{GF 1 B} Fig. 43: GF page 48 {GF 3 C} Fig. 43: GF page 48
E43L	Lamp, Driving/Fog	{GE 0 C} Fig. 42: GE page 47
E43R	Lamp, Driving/Fog	{GE 1 C} Fig. 42: GE page 47
G01	Battery	{BA 0 E} Fig. 5: BA page 10 {AA 2 B} Fig. 1: AA page 6 {DB 4 B} Fig. 24: DB page 29 {HC 0 B} Fig. 51: HC page 56 {CC 2 C} Fig. 18: CC page 23 {CI 1 B} Fig. 22: CI page 27 {DG 0 B} Fig. 29: DG page 34 {AD 3 C} Fig. 4: AD page 9

Component # and Description		Location
G01	Battery	{DF 3 E} Fig. 28: DF page 33
G02	Alternator	{AC 1 C} Fig. 3: AC page 8 {CB 3 B} Fig. 17: CB page 22 {BG 0 B} Fig. 11: BG page 16 {AD 3 B} Fig. 4: AD page 9
G03	Inverter, 12VDC - 120VAC	{HC 0 B} Fig. 51: HC page 56
G04	Power Distribution Unit, 120VAC	{HC 2 B} Fig. 51: HC page 56
H02	Horn	{GQ 0 D} Fig. 48: GQ page 53
H03	Backup Alarm	{GF 1 D} Fig. 43: GF page 48 {GF 1 B} Fig. 43: GF page 48 {GF 4 C} Fig. 43: GF page 48
H07	SMOKE DETECTOR	{IG 2 B} Fig. 62: IG page 67
H07A	SMOKE DETECTOR	{IG 2 B} Fig. 62: IG page 67
H07	SMOKE DETECTOR	{IG 2 B} Fig. 62: IG page 67
M01	WINDSHIELD WIPER MOTOR	{GP 2 D} Fig. 61: IF page 66
M02A	WINDSHIELD WASHER PUMP, VN	{GP 3 B} Fig. 47: GP page 52
M02B	WINDSHIELD WASHER PUMP, VHD	{GP 3 B} Fig. 47: GP page 52
M04	Motor, Starter	{AA 2 A} Fig. 1: AA page 6 {AC 1 B} Fig. 3: AC page 8 {AD 3 B} Fig. 4: AD page 9
M06DS	Motor, Window Winder D.S.	{IC 1 C} Fig. 58: IC page 63
M06PS	Motor, Window Winder P.S.	{IC 2 D} Fig. 58: IC page 63 {ID 0 D} Fig. 59: ID page 64
M110L	Mirror Motors & Heater, LHS	{IC 0 B} Fig. 58: IC page 63 {ID 2 D} Fig. 59: ID page 64
M110R	Mirror Motors & Heater, RHS	{IC 3 B} Fig. 58: IC page 63 {ID 3 D} Fig. 59: ID page 64
M15	Motor, fuel priming pump	{CO 2 B} Fig. 23: CO page 28
M18	MOTOR SINK PUMP	{HE 0 D} Fig. 53: HE page 58

Component # and Description		Location
M19	Motor, EGR control valve	{CO 1 B} Fig. 23: CO page 28
M20L	POWER SEAT, LEFT	{IB 0 D} Fig. 57: IB page 62
M20R	POWER SEAT, RIGHT	{IB 1 D} Fig. 57: IB page 62
M80L	Drivers Side Door Lock Control Assembly	{IE 0 D} Fig. 60: IE page 65 {IA 3 B} Fig. 56: IA page 61 {IA 3 D} Fig. 56: IA page 61 {IA 2 D} Fig. 56: IA page 61
M80R	Passenger Side Door Lock Control Assembly	{IE 0 D} Fig. 60: IE page 65 {IA 3 B} Fig. 56: IA page 61 {IA 4 D} Fig. 56: IA page 61 {IA 3 D} Fig. 56: IA page 61
MFA1	Not Used	{AA 1 D} Fig. 1: AA page 6
MFA2	Fuse F4 & F10 in LECM/ Body Builder	{AA 1 B} Fig. 1: AA page 6 {HB 2 A} Fig. 50: HB page 55 {BG 0 A} Fig. 11: BG page 16
MFA3	FUSE F42-F48	{AA 0 B} Fig. 1: AA page 6
MFA4	DR Relay	{AA 1 B} Fig. 1: AA page 6
MFA5	POWER RELAY 2	{AA 0 B} Fig. 1: AA page 6
MFA6	POWER RELAY 1	{AA 0 B} Fig. 1: AA page 6
MFA7	LCM4	{AA 1 B} Fig. 1: AA page 6 {GB 3 B} Fig. 39: GB page 44
MFA8	Not Used	{AA 1 B} Fig. 1: AA page 6
MFB1	Fuse F1 & F7 in LECM	{HB 1 A} Fig. 50: HB page 55 {AB 3 C} Fig. 2: AB page 7 {HF 2 A} Fig. 54: HF page 59
MFB2	TRAILER AUX	{MA 0 A} Fig. 69: MA page 74 {AB 0 D} Fig. 2: AB page 7
MFB3	POWER RELAY 3	{AB 3 C} Fig. 2: AB page 7
MFB4	POWER RELAY 4	{AB 3 C} Fig. 2: AB page 7
MFB5	Fuse F8-F13	{AB 4 C} Fig. 2: AB page 7
MFB6	Fuses F15-F20	{AB 1 A} Fig. 2: AB page 7
MFB7	BUNK HVAC	{HB 3 A} Fig. 50: HB page 55 {AB 3 C} Fig. 2: AB page 7 {HG 3 A} Fig. 55: HG page 60
MFB8	BUNK FUNCTIONS	{HB 2 A} Fig. 50: HB page 55 {AB 4 C} Fig. 2: AB page 7 {HG 1 A} Fig. 55: HG page 60
R01	Heater, engine preheat	{CO D B} Fig. 23: CO page 28

Component # and Description		Location
R01A	Heater, engine preheat 110V	{CB 2 D} Fig. 17: CB page 22
R01	Heater, engine preheat	{CB 2 C} Fig. 17: CB page 22
R04A	Cigar Lighter	{IF 1 C} Fig. 61: IF page 66
R04B	CIGAR LIGHTER, PANEL	{HD 1 B} Fig. 52: HD page 57 {HE 1 C} Fig. 53: HE page 58
R05A	AIR DRYER	{FA 1 C} Fig. 33: FA page 38
R05B	AIR DRYER	{FA 2 C} Fig. 33: FA page 38
R05C	AIR DRYER	{FA 3 C} Fig. 33: FA page 38
R08	Termination resistor, CAN-bus	{CC 0 B} Fig. 18: CC page 23 {JB 3 D} Fig. 64: JB page 69 {CI 2 B} Fig. 22: CI page 27
R08A	TERMINATION RESISTOR	{BI 2 A} Fig. 13: BI page 18
R08B	TERMINATING RESISTOR	{XA 2 B} Fig. 71: XA page 76
R08C	TERMINATING RESISTOR	{XA 3 B} Fig. 71: XA page 76 {EB 0 B} Fig. 32: EB page 37
R09	Heater, Fuel Filter RH	{CE 0 C} Fig. 19: CE page 24
R09A	Heater, Fuel Filter LH	{CE 1 C} Fig. 19: CE page 24
R09	Heater, Fuel Filter RH	{CE 0 C} Fig. 19: CE page 24
R11	Dome Lamps Relay	{IA 1 C} Fig. 56: IA page 61
R18A	HEATER DRAIN VALVE	{FA 0 C} Fig. 33: FA page 38
R18B	HEATER DRAIN VALVE	{FA 1 C} Fig. 33: FA page 38
S01	Switch, main lighting, selector type	{GA 0 C} Fig. 38: GA page 43
S02	Stalk switch, full- / dipped beams	{BA 2 B} Fig. 5: BA page 10
S04	SWITCH, CLIMATE FAN SELECTOR TYPE	{HB 0 B} Fig. 50: HB page 55
S04A	SWITCH, Sleeper HVAC Fan Speed	{HG 1 B} Fig. 55: HG page 60
S05	Switch Interior Lighting	{HD 0 B} Fig. 52: HD page 57 {HE 2 D} Fig. 53: HE page 58

Component # and Description		Location
S06	WINDSHIELD WIPER SWITCH	{BC 1 C} Fig. 7: BC page 12 {GP 0 C} Fig. 47: GP page 52
S07	Switch, engine brake, selector type	{CF 3 C} Fig. 20: CF page 25 {CF 1 C} Fig. 20: CF page 25 {CF 0 C} Fig. 20: CF page 25
S07B	Switch Engine Brake ON/OFF	{CF 3 C} Fig. 20: CF page 25
S08	Switch, differential gear lock, rear wheels	{FD 1 B} Fig. 36: FD page 41 {FC 1 C} Fig. 35: FC page 40
S09	Switch, differential gear locks, inter axles and rear wheels, selector type	{FD 3 B} Fig. 36: FD page 41 {FC 0 C} Fig. 35: FC page 40
S68	Sensor, coolant level	{CO 2 B} Fig. 23: CO page 28
S103A	Switch, Heated Mirror	{ID 2 B} Fig. 59: ID page 64
S103B	Switch, Motorized Mirror	{ID 3 B} Fig. 59: ID page 64
S104	Switch, Marker Interrupt	{JC 3 C} Fig. 65: JC page 70
S104A	Auxiliary Switch 1	{NA 0 C} Fig. 70: NA page 75
S104B	Auxiliary Switch 2	{NA 1 C} Fig. 70: NA page 75
S104C	Auxiliary Switch 3	{NA 2 C} Fig. 70: NA page 75
S106	Switch, Passenger Window Winder	{ID 1 B} Fig. 59: ID page 64
S11A	SWITCH 1, LIFT AXLE	{FB 0 B} Fig. 34: FB page 39
S11B	SWITCH 2, LIFT AXLE	{FB 1 C} Fig. 34: FB page 39
S11C	SWITCH 3, LIFT AXLE	{FB 2 C} Fig. 34: FB page 39
S11D	Switch, Air Suspension, Manual Control, ON/OFF	{EB 2 D} Fig. 32: EB page 37
S11E	Switch, Suspension Control, UP/DN	{EB 3 D} Fig. 32: EB page 37
S12	SWITCH, SNOWPLOW LAMP	{GI 1 B} Fig. 46: GI page 51
S121	SWITCH, TOUCH LOCK	{BJ 2 C} Fig. 14: BJ page 19
S13	Stalk switch, direction indicator, selector type	{GA 2 B} Fig. 38: GA page 43
S14A	Switch, City Horn/Air Horn	{GQ 1 C} Fig. 48: GQ page 53

Component # and Description		Location
S15	Switch, Ignition	{AB 1 C} Fig. 2: AB page 7
S24	Stalk switch, retarder, selector type	{CF 3 D} Fig. 20: CF page 25
S24A	SWITCH, STALK ALLISON RETARDER	{DE 0 B} Fig. 27: DE page 32
S24C	Switch, ON/OFF Allison Retarder	{DE 2 B} Fig. 27: DE page 32
S28A	Switch, Power Take-Off	{DP 2 C} Fig. 30: DP page 35
S28B	Switch, Power Take-Off	{DP 3 C} Fig. 30: DP page 35
S28C	Switch, Power Take-Off	{DP 4 C} Fig. 30: DP page 35
S28E	SWITCH, VOLVO ACTION SERVICE	{BF 1 D} Fig. 10: BF page 15
S31	Switch, TCS (Traction Control System)	{EA 3 B} Fig. 31: EA page 36
S35	Switch unit, GLU (Gear Lever Unit)	{DC 2 D} Fig. 25: DC page 30
S35M	SWITCH UNIT, GLU (GEAR LEVER UNIT)	{DD 1 D} Fig. 26: DD page 31
S43	Pressure Switch, Parking Brake Indicator	{BA 4 D} Fig. 5: BA page 10
S45	Position switch, differential gear lock indicator, rear wheels, NC. or NO.	{BD 2 B} Fig. 8: BD page 13
S45B	DIFFERENTIAL SWITCH, REAR AXLE	{BD 2 B} Fig. 8: BD page 13
S48	Pressure switch, brake light, NO.	{GB 2 D} Fig. 39: GB page 44
S49	Position switch, reverse lamps, NO.	{GA 2 B} Fig. 38: GA page 43
S58	Position Switch, Clutch Pedal	{BB 3 B} Fig. 6: BB page 11
S59	Position Switch, Brake Pedal	{BB 3 B} Fig. 6: BB page 11
S62	Pressure switch, air pressure, NC.	{FE 0 D} Fig. 37: FE page 42
S68	Proximity switch, coolant level, NC.	{CC 1 E} Fig. 18: CC page 23 {CI 0 D} Fig. 22: CI page 27
S75	SWITCH, BEACON WARNING LIGHT	{GI 3 B} Fig. 46: GI page 51
S76	Switch, spotlights	{GG 0 C} Fig. 44: GG page 49
S80	Door Lock Control Module	{IE 2 B} Fig. 60: IE page 65
S80D	Driver Side Door Control Panel	{IC 2 B} Fig. 58: IC page 63
S80P	Passenger Side Door Control Panel	{IC 2 D} Fig. 58: IC page 63

Component # and Description		Location
S87	SWITCH SINK/ FAUCET	{HE 0 C} Fig. 53: HE page 58
S88	Switch, 5th Wheel Slide	{FD 2 B} Fig. 36: FD page 41 {FB 3 B} Fig. 34: FB page 39
S91	SWITCH, DEAIRATION	{BA 1 B} Fig. 5: BA page 10
S92	Switch, Inverter remote	{HC 0 D} Fig. 51: HC page 56
S93	Switch, Suspension Dump	{FD 1 B} Fig. 36: FD page 41 {FB 3 C} Fig. 34: FB page 39
S97	SWITCH, INSIDE / OUTSIDE AIR CLEANER	{CH 2 C} Fig. 21: CH page 26
S98	Switch, Smoke Detector Disable/Beacon Lamp	{IG 3 D} Fig. 62: IG page 67
W04	Front Antenna, Vorad	{JB 0 E} Fig. 64: JB page 69
X01	Connector, Vehicle Diagnostics	{XA 2 D} Fig. 71: XA page 76
X04	Trailer connection, 7-pole unit, 24 N	{MA 1 D} Fig. 69: MA page 74
X06A	BODY BUILDER CONNECTOR #3	{BI 1 D} Fig. 13: BI page 18
X06B	BODY BUILDER CONNECTOR #4	{BI 3 D} Fig. 11: BG page 16
X06C	BODY BUILDER CONNECTOR #1	{BG 0 D} Fig. 11: BG page 16
X06D	BODY BUILDER CONNECTOR #2	{BG 2 B} Fig. 11: BG page 16
X06F	BODY BUILDER CAMERA PREP	{BG 1 B} Fig. 11: BG page 16
X07A	12V SOCKET	{IF 0 C} Fig. 61: IF page 66
X07B	12V SOCKET, PANEL	{HD 1 C} Fig. 52: HD page 57 {HE 1 B} Fig. 53: HE page 58
X07C	12V SOCKET, D.S. CABINET	{HE 2 C} Fig. 53: HE page 58
X07D	12V SOCKET, TV/VCR	{HD 1 C} Fig. 52: HD page 57 {HE 2 B} Fig. 53: HE page 58
X07E	12V SOCKET, RADIO SHELF	{IF 2 C} Fig. 61: IF page 66
X07F	12V STUDS, CB OVERHEAD	{IF 3 C} Fig. 61: IF page 66
X07G	12V STUDS, CB DASH	{IF 3 C} Fig. 61: IF page 66

Component # and Description		Location
X08	Contact reel, air bag	{GA 3 B} Fig. 38: GA page 43 {JA 1 D} Fig. 63: JA page 68 {JC 0 D} Fig. 65: JC page 70
X0A	SPLICE PACK	{HB 0 E} Fig. 50: HB page 55 {AC 3 C} Fig. 3: AC page 8 {FD 0 D} Fig. 36: FD page 41 {FD 0 D} Fig. 36: FD page 41 {FD 0 E} Fig. 36: FD page 41 {DE 3 D} Fig. 27: DE page 32 {FB 3 D} Fig. 34: FB page 39 {FB 3 E} Fig. 34: FB page 39 {CH 2 D} Fig. 21: CH page 26 {FC 1 D} Fig. 35: FC page 40
X0B	SPLICE PACK	{HD 0 E} Fig. 52: HD page 57 {AC 3 C} Fig. 3: AC page 8 {DP 2 E} Fig. 30: DP page 35 {IB 0 D} Fig. 57: IB page 62 {DE 3 D} Fig. 27: DE page 32 {DE 3 D} Fig. 27: DE page 32 {IG 3 E} Fig. 62: IG page 67 {FB 0 D} Fig. 34: FB page 39 {HE 3 E} Fig. 53: HE page 58
X0D	SPLICE PACK	{AA 0 D} Fig. 1: AA page 6 {HB 1 E} Fig. 50: HB page 55 {AC 3 C} Fig. 3: AC page 8 {GI 0 D} Fig. 46: GI page 51 {IB 1 D} Fig. 57: IB page 62 {JB 4 D} Fig. 64: JB page 69 {FB 3 C} Fig. 34: FB page 39 {EB 3 E} Fig. 32: EB page 37

Component # and Description		Location
X0X	SPLICE PACK	{BA 2 E} Fig. 5: BA page 10 {IE 2 D} Fig. 60: IE page 65 {AC 0 B} Fig. 3: AC page 8 {XA 1 E} Fig. 71: XA page 76 {GI 3 E} Fig. 46: GI page 51 {DC 1 D} Fig. 25: DC page 30 {DC 0 D} Fig. 25: DC page 30 {JC 1 D} Fig. 65: JC page 70 {DD 0 E} Fig. 26: DD page 31 {BI 0 D} Fig. 13: BI page 18 {BK 1 D} Fig. 15: BK page 20
X13	Connector, CTI configuration	{FE 0 C} Fig. 37: FE page 42
X14	ROAD RELAY CONNECTOR	{BH 0 C} Fig. 12: BH page 17
X17A	Auxiliary Connector 1	{NA 0 D} Fig. 70: NA page 75
X17B	Auxiliary Connector 2	{NA 1 D} Fig. 70: NA page 75
X17C	Auxiliary Connector 3	{NA 2 D} Fig. 70: NA page 75
X17CA	OPTION CONNECTOR A,CAB SIDE	{BG 3 C} Fig. 11: BG page 16
X17CB	OPTION CONNECTOR B,CAB SIDE	{BG 3 C} Fig. 11: BG page 16
X17FA	OPTION CONNECTOR A, CHASSIS SIDE	{BG 3 C} Fig. 11: BG page 16
X17FB	OPTION CONNECTOR B,CHASSIS SIDE	{BG 3 C} Fig. 11: BG page 16
X18A	Fusible Link	{AA 2 B} Fig. 1: AA page 6 {AB 4 A} Fig. 2: AB page 7
X18C	Fusible Link	{AC 1 C} Fig. 3: AC page 8
X18D	Fusible Link	{CB 2 C} Fig. 17: CB page 22
X18E	Fusible Link	{CB 2 C} Fig. 17: CB page 22
X19	RADIO CONNECTOR	{BH 4 B} Fig. 12: BH page 17
X20	MAIN CAB RADIO CONNECTOR	{BH 3 B} Fig. 12: BH page 17
X21	OPTION CONNECTOR SNOWPLOW LIGHTS	{GI 1 D} Fig. 46: GI page 51
X23	Connector, Interface V.A.L.	{BF 2 B} Fig. 10: BF page 15
X25	Connector, OEM Interface	{CI 0 C} Fig. 22: CI page 27

Component # and Description		Location
X284/196DR	SPLICE PACK	{AB 0 A} Fig. 2: AB page 7
X400	SPLICE PACK	{XA 0 B} Fig. 71: XA page 76
X401	SPLICE PACK	{XA 1 B} Fig. 71: XA page 76
X45	Receptacle Engine Heater 110V	{CA 2 B} Fig. 16: CA page 21
XE1	Stud, Engine Block	{AC 1 D} Fig. 3: AC page 8
XP1	POWER STUD	{AA 1 A} Fig. 1: AA page 6
XP2	POWER STUD	{AB 3 B} Fig. 2: AB page 7
Y11	Solenoid valve unit, ABS, lhs. front	{EA 1 B} Fig. 31: EA page 36
Y12	Solenoid valve unit, ABS, rhs. front	{EA 0 B} Fig. 31: EA page 36
Y13	Solenoid valve unit, ABS, lhs. rear	{EA 1 D} Fig. 31: EA page 36
Y14	Solenoid valve unit, ABS, rhs. rear	{EA 1 D} Fig. 31: EA page 36
Y15	Solenoid valve unit, ABS, lhs. 3:rd axle	{EA 3 D} Fig. 31: EA page 36
Y16	Solenoid valve unit, ABS, rhs. 3:rd axle	{EA 3 D} Fig. 31: EA page 36
Y17	Solenoid Retarder	{DE 2 D} Fig. 27: DE page 32
Y18A	SOLENOID VALVE SINGLE PTO	{DP 0 D} Fig. 30: DP page 35
Y18B	SOLENOID VALVE ENGINE MOUNTED DUAL PTO	{DP 4 D} Fig. 30: DP page 35
Y25A	Solenoid, Level Control Main Axles	{EB 1 B} Fig. 32: EB page 37
Y29A	Solenoid, Level Control Tag Axle	{EB 2 B} Fig. 32: EB page 37
Y33	Solenoid valves, UI (Unit Injector)	{CO 1 D} Fig. 23: CO page 28
Y34A	Control valve, EGR (Exhaust Gas Recirculation) (Including M19, B65)	{CO 1 B} Fig. 23: CO page 28
Y34B	Control valve, EGR (Exhaust Gas Recirculation) (Including M19, B65)	{CO 1 B} Fig. 23: CO page 28
Y35	Solenoid valve engine cooling fan	{CO 4 B} Fig. 23: CO page 28
Y37	AVU (Air Valve Unit)	{CO 3 B} Fig. 23: CO page 28
Y39	Solenoid valve, VCB (Volvo Compression Brake)	{CO 3 B} Fig. 23: CO page 28
Y42	Clutch, magnetic, air conditioning compressor	{HA 1 C} Fig. 49: HA page 54
Y50	Solenoid valve, PCU (Pneumatic Control Unit)	{FE 3 D} Fig. 37: FE page 42

Component # and Description		Location
Y51	Solenoid valve, Air dryer	{FA 3 C} Fig. 33: FA page 38
Y53	SOLENOID, ETHER START	{CA 0 C} Fig. 16: CA page 21
Y53A	SOLENOID PACK, PRIMARY	{FD 2 D} Fig. 36: FD page 41 {GQ 2 C} Fig. 48: GQ page 53 {FC 1 D} Fig. 35: FC page 40
Y53A_1	SOLENOID PACK, PRIMARY	{FD 1 D} Fig. 36: FD page 41
Y53B	SOLENOID PACK, SECONDARY	{DP 0 C} Fig. 30: DP page 35 {FB 1 D} Fig. 34: FB page 39 {FB 1 D} Fig. 34: FB page 39 {BJ 2 D} Fig. 14: BJ page 19
Y53B_1	SOLENOID PACK, SECONDARY	{FB 3 D} Fig. 34: FB page 39
Y57	Solenoid Valve, ACT	{EA 1 D} Fig. 31: EA page 36
Y62	Solenoid Accumulator	{DE 3 D} Fig. 27: DE page 32
earth15_27	*opt*	{BH 0 E} Fig. 12: BH page 17
earth16_27	*opt*	{BJ 1 D} Fig. 14: BJ page 19
earth17_27	*opt*	{GC 4 E} Fig. 40: GC page 45
free1_52	*opt*	{IE 2 C} Fig. 60: IE page 65
MC141A:D	*opt*	{BJ 1 B} Fig. 14: BJ page 19
MC141A:G	*opt*	{NA 0 B} Fig. 70: NA page 75
MC141A:H	*opt*	{IG 3 A} Fig. 62: IG page 67
MC141A:J	*opt*	{BF 0 B} Fig. 10: BF page 15
MC141A:K	*opt*	{NA 1 A} Fig. 70: NA page 75
MC141A:L	*opt*	{NA 3 B} Fig. 70: NA page 75
MC141A-B:F	*opt*	{EB 4 B} Fig. 32: EB page 37
MCFC:69	*opt*	{BJ 2 C} Fig. 14: BJ page 19
MCFC:94	*opt*	{BJ 2 C} Fig. 14: BJ page 19

Component # and Description		Location
TREN1:27	*opt*	{CC 1 D} Fig. 18: CC page 23
TREN1:36	*opt*	{CC 1 D} Fig. 18: CC page 23
X0X:M	*opt*	{BK 1 D} Fig. 15: BK page 20
XC1	Stud, Bulkhead Inside Cab	{AD 4 E} Fig. 4: AD page 9
XC1_1	Stud, Bulkhead Inside	{BE 0 E} Fig. 9: BE page 14
XC1_2	Stud, Bulkhead Interior	{JA 2 D} Fig. 63: JA page 68
XE1_1	Stud, Engine Block	{CC 2 E} Fig. 18: CC page 23 {CI 4 E} Fig. 22: CI page 27
XF1	Stud, Framerrail	{AC 1 E} Fig. 3: AC page 8
XF1_1	Stud, Framerrail	{MA 1 E} Fig. 69: MA page 74
XG2	Stud 2, Bulkhead	{AC 3 E} Fig. 3: AC page 8
XG2:1	Stud 2, Bulkhead	{EA 4 E} Fig. 31: EA page 36
XG3	Stud 3, Bulkhead	{AC 3 E} Fig. 3: AC page 8
XG3:1	Stud 3 Bulkhead	{HA 1 E} Fig. 49: HA page 54
XG3:2	Stud 3 Bulkhead	{BG 0 D} Fig. 11: BG page 16
XG4	Stud 4, Bulkhead	{AC 3 E} Fig. 3: AC page 8
XG4:1	Ground Point 4 Bulkhead	{EB 0 E} Fig. 32: EB page 37
XG5	Stud 1, Bulkhead	{AC 3 E} Fig. 3: AC page 8
XG5:1	Stud 1, Bulkhead	{GD 0 E} Fig. 41: GD page 46
XG5:2	Stud 2, Bulkhead	{FE 2 E} Fig. 37: FE page 42
XG5:3	Stud 1, Bulkhead	{CE 0 D} Fig. 19: CE page 24
XG6	Stud, Bulkhead	{AD 2 E} Fig. 4: AD page 9
XG7	Stud, Bulkhead	{AC 2 E} Fig. 3: AC page 8
XG7:1	Stud, Bulkhead	{HA 1 E} Fig. 49: HA page 54 {CA 1 D} Fig. 16: CA page 21
XG7:2	Stud, Bulkhead	{DP 0 E} Fig. 30: DP page 35
XG9	Stud, Behind Alt.	{CB 2 D} Fig. 17: CB page 22

Reference List: Inline Connectors

Inline connectors are named by combining a set of harness abbreviations. The first abbreviation represents the feeding harness. In some cases, more than one connector is between two harnesses. In this case a number is added to the end of the abbreviation.

Example:

MCSL2:3 Main Cab and Sleeper Harness Inline, Connector 2, Pin 3

MCSL4:C Main Cab and Sleeper Harness Inline, Connector 4, Pin C

Harness Abbreviations (Examples)			
NAME	HARNESS	NAME	HARNESS
AD	AIR DRIER	PL	SNOWPLOW OVERLAY
ALS	ALLISON SELECTOR - GEAR	PM	POWER MODULE
AR	AIR RESTRICTION JUMPER	PS	PREMIUM SOUND OVERLAY
AS	AUTOSHIFT	PTO	POWER TAKE-OFF
AT	ALLISON TRANSMISSION	QC	QUALCOMM
B	EXPANSION BLOCK	RA	REAR AXLE
BB	BODY BUILDER DASH OVERLAY	RAJ	REAR AXLE JUMPER
BOC	BACK OF CAB LAMP JUMPER	RF	ROOF SIGN
BP	BATTERY POWER - ENGINE	RFJ	ROOF SIGN JUMPER
CB	C.B. STUDS JUMPER	RH	REAR WALL HEADER
CE	CHASSIS EXTENSION	RJ	RADIO JUMPER
DL	DOOR - LEFT	RS	RADIO SHELF PREP.
DLR	DIFFERENTIAL LOCK	RW	REAR WALL
DR	DOOR - RIGHT	SK	SINK/FAUCET PUMP
DV	DRAIN VALVE HEATER	SL	SLEEPER
EB	ENGINE BRAKE JUMPER	SN	SHIFT KNOB
EN	ENGINE	SP	SPEAKER JUMPER
FA	FRONT ANTENNA	SPJ	SOLENOID PACK JUMPER
FC	FRONT CHASSIS	SPO	SNOWPLOW OPTION
FCJ	FUEL COOLER JUMPER	SS	SIDE SENSOR (VORAD)
FD	FOG AND DRIVING LAMPS	SSO	SPEED SIGNAL OPTION (NO HARNESS)
FRC	FUSE AND RELAY CENTER	SV	SUNVISOR
HL	HEADLIGHT	SW	STEERING WHEEL SWITCHES
IJ	ICON JUMPER	TBJ	TABLE LAMP JUMPER
LA	LIFT AXLE OVERLAY	TBP	TRANSMISSION BATTERY POWER
LK	DOOR LOCK OVERLAY	TL	TAILLIGHT
MC	MAIN CAB	TR	TRANSMISSION
MI	MARKER INTERRUPT	TSJ	TEMP SWITCH JUMPER
MJ	MIRROR JUMPER	TT	TRANSMISSION TEMP
OB	OVERHEAD BUNK	VA	REAR WALL VALANCE
OCP	OVERCRANK PROTECTION		
OF	OVERHEAD FRONT		
OPT	OPTION CONNECTOR IN DASH		

Harness Abbreviations (Examples)			
NAME	HARNESS	NAME	HARNESS
PHC	PREHEATER, CUMMINS		
PHV	PREHEATER, VOLVO		
PJ	PREHEAT JUMPER		

List of Connectors

Inline Connector	Location		
A45:1-5, 7	{CO 2 A} Fig. 23: CO page 28	CETL:A	{GF 3 A} Fig. 43: GF page 48 {GF 1 B} Fig. 43: GF page 48
B1-1:1	{NA 1 D} Fig. 70: NA page 75	CETL:B	{GF 2 A} Fig. 43: GF page 48 {GF 0 B} Fig. 43: GF page 48
B1-1:2	{NA 0 B} Fig. 70: NA page 75	CETL:C	{GF 2 A} Fig. 43: GF page 48 {GF 0 B} Fig. 43: GF page 48
B1-2:1	{NA 2 D} Fig. 70: NA page 75	CETL:D	{GF 2 A} Fig. 43: GF page 48 {GF 0 B} Fig. 43: GF page 48
B1-2:2	{NA 1 B} Fig. 70: NA page 75	CETL:E	{GF 3 A} Fig. 43: GF page 48 {GF 1 B} Fig. 43: GF page 48
B1-3:1	{NA 3 D} Fig. 70: NA page 75		{GF 3 E} Fig. 43: GF page 48
B1-3:2	{NA 2 B} Fig. 70: NA page 75		{GF 1 C} Fig. 43: GF page 48 {GF 1 C} Fig. 43: GF page 48
B1-4:1	{BJ 1 D} Fig. 14: BJ page 19	DVAD:A	{FA 1 D} Fig. 33: FA page 38
B1-4:2	{BJ 2 B} Fig. 14: BJ page 19	DVAD:B	{FA 1 B} Fig. 33: FA page 38
	{BK 2 B} Fig. 15: BK page 20	DVDV:A	{FA 1 C} Fig. 33: FA page 38
B1-5:2	{BF 1 B} Fig. 10: BF page 15	DVDV:B	{FA 1 B} Fig. 33: FA page 38
B1-6:1	{BF 2 E} Fig. 10: BF page 15	EM:1-12	{CO 0 A} Fig. 23: CO page 28
B1-6:2	{BF 1 B} Fig. 10: BF page 15	ENBP:A	{AC 0 D} Fig. 3: AC page 8
B2:B2-1_2	{BH 1 B} Fig. 12: BH page 17	ENBP:B	{BA 0 D} Fig. 8: BD page 13
B2:B2-2_1	{BH 0 D} Fig. 12: BH page 17	ENEN1:A	{AD 4 D} Fig. 4: AD page 9
B2:B2-2_2	{BH 1 B} Fig. 12: BH page 17	ENEN1:B	{AD 4 D} Fig. 4: AD page 9
B2:B2-3_1	{AC 3 D} Fig. 3: AC page 8	ENOC:P:A	{AD 4 C} Fig. 4: AD page 9 {AD 3 C} Fig. 4: AD page 9
B2:B2-3_2	{AB 4 E} Fig. 2: AB page 7	ENOC:P:B	{AD 4 D} Fig. 4: AD page 9 {AD 3 D} Fig. 4: AD page 9
B2:B2-5_1	{GC 4 D} Fig. 40: GC page 45	FCAD:A	{FA 3 D} Fig. 33: FA page 38 {FA 2 D} Fig. 33: FA page 38 {FA 1 D} Fig. 33: FA page 38 {FA 0 D} Fig. 33: FA page 38
B2:B2-5_2	{GC 2 B} Fig. 40: GC page 45	FCAD:B	{FA 3 B} Fig. 33: FA page 38 {FA 2 B} Fig. 33: FA page 38 {FA 1 B} Fig. 33: FA page 38 {FA 0 B} Fig. 33: FA page 38
	{BK 2 B} Fig. 15: BK page 20	FCAR:A	{BD 1 C} Fig. 8: BD page 13
	{BK 2 B} Fig. 15: BK page 20	FCAR:B	{BD 1 B} Fig. 8: BD page 13
B3:R15_30	{DF 1 C} Fig. 28: DF page 33	FCCE:A	{GF 1 C} Fig. 43: GF page 48 {GF 1 A} Fig. 43: GF page 48
B3:R15_85	{DF 1 B} Fig. 28: DF page 33	FCCE:B	{GF 0 C} Fig. 43: GF page 48 {GF 0 A} Fig. 43: GF page 48
B3:R15_86	{DF 1 C} Fig. 28: DF page 33	FCCE:C	{GF 0 C} Fig. 43: GF page 48 {GF 0 A} Fig. 43: GF page 48
B3:R15_87	{DF 1 B} Fig. 28: DF page 33	FCCE:D	{GF 1 C} Fig. 43: GF page 48 {GF 1 A} Fig. 43: GF page 48
B3:R16_30	{BA 3 B} Fig. 5: BA page 10	FCCE:E	{BD 2 C} Fig. 8: BD page 13
B3:R16_85	{BA 3 C} Fig. 5: BA page 10	FCCE:F	{BC 3 B} Fig. 7: BC page 12
B3:R16_86	{BA 3 B} Fig. 5: BA page 10	FCCE:G	{BC 3 B} Fig. 7: BC page 12
B3:R16_87	{BA 3 C} Fig. 5: BA page 10	FCCE:H	{BD 2 D} Fig. 8: BD page 13
B3:R17_30	{BA 3 B} Fig. 5: BA page 10	FCCE:J	{GF 1 D} Fig. 43: GF page 48 {GF 1 C} Fig. 43: GF page 48
B3:R17_85	{BA 3 B} Fig. 5: BA page 10		
B3:R17_86	{BA 3 B} Fig. 5: BA page 10		
B3:R17_87	{BA 3 B} Fig. 5: BA page 10		
B3:R18_30	{DF 2 C} Fig. 28: DF page 33		
B3:R18_85	{DF 2 B} Fig. 28: DF page 33		
B3:R18_86	{DF 2 C} Fig. 28: DF page 33		
B3:R18_87	{DF 2 B} Fig. 28: DF page 33		
CERAJ1:A	{BD 2 B} Fig. 8: BD page 13		
CERAJ1:B	{BD 2 C} Fig. 8: BD page 13		
CERAJ1:C	{BC 3 B} Fig. 7: BC page 12		
CERAJ2:A	{BD 2 B} Fig. 8: BD page 13		
CERAJ2:B	{BD 3 C} Fig. 8: BD page 13		
CERAJ2:C	{BC 3 B} Fig. 7: BC page 12		
CETE:A	{GF 2 A} Fig. 43: GF page 48		
CETE:B	{GF 0 A} Fig. 43: GF page 48		
CETE:C	{GF 0 A} Fig. 43: GF page 48		
CETE:D	{GF 0 A} Fig. 43: GF page 48		
CETE:E	{GF 1 C} Fig. 43: GF page 48		

FCDV:A	{FA 0 D} Fig. 33: FA page 38	FCHL:G	{GD 0 B} Fig. 41: GD page 46
FCDV:B	{FA 0 B} Fig. 33: FA page 38		{GD 3 B} Fig. 41: GD page 46
FCEN1:A	{XA 3 D} Fig. 71: XA page 76		{GD 2 B} Fig. 41: GD page 46
FCEN1:B	{XA 3 D} Fig. 71: XA page 76		{GD 0 B} Fig. 41: GD page 46
FCEN1:C	{BC 2 B} Fig. 7: BC page 12	FCHL:H	{GD 3 C} Fig. 41: GD page 46
FCEN1:D	{AD 3 C} Fig. 7: BC page 12		{GD 1 C} Fig. 41: GD page 46
FCEN1:E	{XA 0 D} Fig. 71: XA page 76		{GD 0 C} Fig. 41: GD page 46
FCEN1:F	{XA 1 D} Fig. 71: XA page 76		{GD 0 C} Fig. 41: GD page 46
FCEN1:J	{CB 0 C} Fig. 17: CB page 22	FCHL:J	{GD 3 C} Fig. 41: GD page 46
FCEN1:K	{HA 1 C} Fig. 49: HA page 54		{GD 2 C} Fig. 41: GD page 46
FCEN1:L	{CB 2 B} Fig. 17: CB page 22		{GD 1 C} Fig. 41: GD page 46
FCEN1:M	{BB 2 C} Fig. 6: BB page 11		{GD 1 C} Fig. 41: GD page 46
FCEN2:A	{AC 0 C} Fig. 3: AC page 8	FCHL:K	{BC 3 B} Fig. 7: BC page 12
FCEN2:B	{AD 1 B} Fig. 4: AD page 9	FCHL:L	{BC 3 A} Fig. 7: BC page 12
	{AD 2 B} Fig. 4: AD page 9	FCHL:M	{GD 2 B} Fig. 41: GD page 46
	{AD 2 B} Fig. 4: AD page 9	FCPTO:A	{DP 4 D} Fig. 30: DP page 35
FCEN2:C	{AD 3 B} Fig. 4: AD page 9	FCPTO1:A	{DP 0 C} Fig. 30: DP page 35
FCEN2:D	{BG 0 C} Fig. 11: BG page 16	FCPTO1:B	{DP 0 D} Fig. 30: DP page 35
	{AD 2 B} Fig. 4: AD page 9	FCSPJ:A	{FB 2 D} Fig. 34: FB page 39
FCEN2:F	{BA 0 C} Fig. 5: BA page 10	FCSPJ:B	{FB 3 D} Fig. 34: FB page 39
	{AD 2 B} Fig. 4: AD page 9	FCSPJ:C	{FB 2 D} Fig. 34: FB page 39
FCEN2:G	{CB 1 C} Fig. 17: CB page 22	FCSPJ:D	{FB 2 D} Fig. 34: FB page 39
FCEN2:H	{CC 1 C} Fig. 18: CC page 23	FCSPJ:F	{FB 3 D} Fig. 34: FB page 39
	{CI 3 C} Fig. 22: CI page 27	FCSPJ:G	{FB 3 D} Fig. 34: FB page 39
FCEN2:J	{CB 1 C} Fig. 17: CB page 22	FCSPJ:H	{FB 2 D} Fig. 34: FB page 39
FCFA:A	{JB 0 D} Fig. 64: JB page 69	FCSPJ1:C	{FD 0 C} Fig. 36: FD page 41
FCFA:B	{JB 0 D} Fig. 64: JB page 69	FCSPJ1:D	{FD 0 C} Fig. 36: FD page 41
FCFA:C	{JB 0 D} Fig. 64: JB page 69	FCSPJ1:H	{FD 0 D} Fig. 36: FD page 41
FCFA:D	{JB 0 D} Fig. 64: JB page 69	FCSPJ2:E	{FD 0 C} Fig. 36: FD page 41
FCFD1:A	{GE 1 B} Fig. 42: GE page 47	FCSPJ4:A	{FB 3 D} Fig. 34: FB page 39
	{GE 0 B} Fig. 42: GE page 47	FCSS:A	{JB 1 D} Fig. 64: JB page 69
FCFD1:B	{GE 2 B} Fig. 42: GE page 47	FCSS:B	{JB 2 D} Fig. 64: JB page 69
	{GE 1 B} Fig. 42: GE page 47	FCSS:C	{JB 1 D} Fig. 64: JB page 69
FCFD1:C	{GE 2 C} Fig. 42: GE page 47	FCTR:1	{XA 2 D} Fig. 71: XA page 76
	{GE 0 C} Fig. 42: GE page 47	FCTR:2	{XA 4 D} Fig. 71: XA page 76
	{GE 0 D} Fig. 42: GE page 47	FRC:BI-4_2	{AA 3 D} Fig. 1: AA page 6
FCHL:A	{GD 1 B} Fig. 41: GD page 46	FRC:F1_B	{IC 2 A} Fig. 58: IC page 63
	{GD 1 B} Fig. 41: GD page 46		{ID 3 A} Fig. 59: ID page 64
	{GD 4 B} Fig. 41: GD page 46	FRC:F10_A	{AB 3 C} Fig. 2: AB page 7
FCHL:B	{GD 2 B} Fig. 41: GD page 46	FRC:F10_B	{GB 2 B} Fig. 39: GB page 44
	{GD 1 B} Fig. 41: GD page 46	FRC:F11_B	{BF 1 B} Fig. 10: BF page 15
	{GD 4 B} Fig. 41: GD page 46		{BK 2 B} Fig. 15: BK page 20
	{GD 2 B} Fig. 41: GD page 46	FRC:F12_B	{BH 1 B} Fig. 12: BH page 17
	{GD 1 B} Fig. 41: GD page 46	FRC:F13_B	{XA 2 B} Fig. 71: XA page 76
FCHL:C	{GD 0 B} Fig. 41: GD page 46	FRC:F14_B	{BE 0 B} Fig. 9: BE page 14
	{GD 3 B} Fig. 41: GD page 46	FRC:F15_B	{AB 1 B} Fig. 2: AB page 7
	{GD 1 B} Fig. 41: GD page 46	FRC:F16_B	{AB 2 B} Fig. 2: AB page 7
	{GD 0 B} Fig. 41: GD page 46	FRC:F17_B	{GB 3 A} Fig. 39: GB page 44
FCHL:D	{GD 0 B} Fig. 41: GD page 46	FRC:F18_A	{AB 2 B} Fig. 2: AB page 7
	{GD 3 B} Fig. 41: GD page 46	FRC:F18_B	{GB 1 B} Fig. 39: GB page 44
	{GD 1 B} Fig. 41: GD page 46	FRC:F19_B	{DC 0 B} Fig. 25: DC page 30
	{GD 0 B} Fig. 41: GD page 46	FRC:F2_B	{KA 0 B} Fig. 66: KA page 71
FCHL:E	{GD 0 B} Fig. 41: GD page 46		{KB 2 B} Fig. 67: KB page 72
	{GD 3 B} Fig. 41: GD page 46		{KC 0 A} Fig. 68: KC page 73
	{GD 2 B} Fig. 41: GD page 46	FRC:F20_B	{HB 1 B} Fig. 50: HB page 55
	{GD 0 B} Fig. 41: GD page 46		{GI 3 B} Fig. 46: GI page 51
FCHL:F	{GD 1 B} Fig. 41: GD page 46	FRC:F21_A	{CC 1 B} Fig. 18: CC page 23
	{GD 4 B} Fig. 41: GD page 46		{CI 3 B} Fig. 22: CI page 27
	{GD 2 B} Fig. 41: GD page 46	FRC:F21_B	{CC 1 B} Fig. 18: CC page 23
	{GD 1 B} Fig. 41: GD page 46		{CI 3 C} Fig. 22: CI page 27
		FRC:F22_B	{CE 0 B} Fig. 19: CE page 24
		FRC:F23_B	{HA 0 B} Fig. 49: HA page 54
		FRC:F24_B	{BC 0 B} Fig. 7: BC page 12

FRC:F25_A	{AA 1 D} Fig. 1: AA page 6	FRC:F66_B	{BG 0 B} Fig. 11: BG page 16
FRC:F25_B	{IB 1 B} Fig. 57: IB page 62	FRC:F68_B	{IE 1 B} Fig. 60: IE page 65
FRC:F26_B	{GP 0 B} Fig. 47: GP page 52	FRC:F69_B	{BF 1 B} Fig. 10: BF page 15
FRC:F27_B	{FD 3 A} Fig. 36: FD page 41	FRC:F70_B	{JB 2 B} Fig. 64: JB page 69
	{FC 0 B} Fig. 35: FC page 40		{EB 3 B} Fig. 32: EB page 37
FRC:F28_B	{FD 1 A} Fig. 36: FD page 41	FRC:F72_A	{AA 2 C} Fig. 1: AA page 6
	{FC 1 B} Fig. 35: FC page 40	FRC:F72_B	{DB 0 A} Fig. 24: DB page 29
FRC:F29_B	{BG 1 B} Fig. 11: BG page 16		{DC 0 B} Fig. 25: DC page 30
FRC:F3_B	{IC 1 A} Fig. 58: IC page 63		{DD 1 B} Fig. 26: DD page 31
	{ID 2 A} Fig. 59: ID page 64		{DG 1 A} Fig. 29: DG page 34
FRC:F30_B	{IB 0 B} Fig. 57: IB page 62		{DF 1 B} Fig. 28: DF page 33
FRC:F31_B	{IB 1 B} Fig. 57: IB page 62	FRC:F75_B	{DP 2 B} Fig. 30: DP page 35
FRC:F32_A	{AA 2 D} Fig. 1: AA page 6	FRC:F76_B	{CF 2 A} Fig. 20: CF page 25
FRC:F32_B	{AA 3 D} Fig. 1: AA page 6	FRC:F77_A	{DF 3 B} Fig. 28: DF page 33
FRC:F33_B	{GI 1 B} Fig. 46: GI page 51	FRC:F77_B	{DF 3 B} Fig. 28: DF page 33
FRC:F34_B	{FE 1 A} Fig. 37: FE page 42	FRC:F78_A	{DF 0 B} Fig. 28: DF page 33
FRC:F35_B	{GI 1 B} Fig. 46: GI page 51	FRC:F78_B	{DF 0 B} Fig. 28: DF page 33
FRC:F36_B	{IF 0 B} Fig. 61: IF page 66	FRC:F79_A	{BA 0 A} Fig. 5: BA page 10
FRC:F37_B	{IA 1 B} Fig. 56: IA page 61	FRC:F79_B	{BA 0 A} Fig. 5: BA page 10
FRC:F38_A	{AA 0 D} Fig. 1: AA page 6	FRC:F8_B	{GB 2 A} Fig. 39: GB page 44
FRC:F39_B	{IF 3 B} Fig. 61: IF page 66	FRC:F80_A	{BA 0 A} Fig. 5: BA page 10
FRC:F4_A	{AB 3 D} Fig. 2: AB page 7	FRC:F80_B	{BA 1 B} Fig. 5: BA page 10
FRC:F4_B	{IC 3 A} Fig. 58: IC page 63	FRC:F81_B	{BA 0 A} Fig. 5: BA page 10
	{ID 1 A} Fig. 59: ID page 64	FRC:F82_B	{BA 0 A} Fig. 5: BA page 10
FRC:F40_B	{EB 4 A} Fig. 32: EB page 37	FRC:F9_B	{MA 0 B} Fig. 69: MA page 74
FRC:F41_B	{GQ 2 B} Fig. 48: GQ page 53	FRC:R1_30	{AA 2 C} Fig. 1: AA page 6
FRC:F42_B	{GB 3 B} Fig. 39: GB page 44	FRC:R1_85	{AA 2 C} Fig. 1: AA page 6
FRC:F43_B	{GB 2 A} Fig. 39: GB page 44	FRC:R1_86	{AA 2 C} Fig. 1: AA page 6
FRC:F44_A	{AA 0 C} Fig. 1: AA page 6	FRC:R1_87	{AA 2 C} Fig. 1: AA page 6
FRC:F44_B	{GB 3 A} Fig. 39: GB page 44	FRC:R10_30	{GQ 0 B} Fig. 48: GQ page 53
FRC:F45_B	{GQ 0 B} Fig. 48: GQ page 53	FRC:R10_85	{GQ 0 C} Fig. 48: GQ page 53
FRC:F46_B	{BC 0 B} Fig. 7: BC page 12	FRC:R10_86	{GQ 0 C} Fig. 48: GQ page 53
	{KA 1 B} Fig. 66: KA page 71	FRC:R10_87	{GQ 0 C} Fig. 48: GQ page 53
	{KB 2 B} Fig. 66: KA page 71	FRC:R11_30	{IE 1 C} Fig. 60: IE page 65
	{KC 1 A} Fig. 68: KC page 73	FRC:R11_85	{IA 3 B} Fig. 56: IA page 61
FRC:F47_B	{HA 0 B} Fig. 49: HA page 54		{IA 3 C} Fig. 56: IA page 61
FRC:F48_B	{IE 1 B} Fig. 60: IE page 65		{IA 2 D} Fig. 56: IA page 61
FRC:F49_B	{NA 0 B} Fig. 70: NA page 75	FRC:R11_86	{IA 2 C} Fig. 56: IA page 61
FRC:F5_B	{JC 0 B} Fig. 65: JC page 70	FRC:R11_87	{IA 1 C} Fig. 56: IA page 61
FRC:F50_B	{NA 1 B} Fig. 70: NA page 75	FRC:R12_85	{GP 0 C} Fig. 47: GP page 52
FRC:F51_A	{AA 1 D} Fig. 1: AA page 6	FRC:R12_86	{GP 0 C} Fig. 47: GP page 52
FRC:F51_B	{NA 2 B} Fig. 70: NA page 75	FRC:R12_87	{GP 0 B} Fig. 47: GP page 52
FRC:F52_B	{HB 1 B} Fig. 50: HB page 55	FRC:R12_87A	{GP 0 B} Fig. 47: GP page 52
FRC:F53_B	{IF 2 B} Fig. 61: IF page 66	FRC:R13_30	{GB 1 B} Fig. 47: GP page 52
FRC:F54_B	{GC 2 A} Fig. 40: GC page 45	FRC:R13_85	{DB 1 B} Fig. 24: DB page 29
	{BK 2 B} Fig. 15: BK page 20		{DF 0 B} Fig. 28: DF page 33
FRC:F56_B	{FA 2 A} Fig. 33: FA page 38	FRC:R13_86	{DB 1 B} Fig. 24: DB page 29
FRC:F57_B	{JA 1 B} Fig. 63: JA page 68		{DF 0 C} Fig. 28: DF page 33
FRC:F58_B	{FB 0 B} Fig. 34: FB page 39	FRC:R13_87	{DB 1 B} Fig. 24: DB page 29
FRC:F59_A	{AB 1 D} Fig. 2: AB page 7		{DF 0 C} Fig. 28: DF page 33
FRC:F59_B	{BE 1 B} Fig. 9: BE page 14	FRC:R13_87A	{DB 1 B} Fig. 24: DB page 29
	{CH 2 B} Fig. 21: CH page 26		{DF 0 B} Fig. 28: DF page 33
FRC:F6_B	{AB 4 D} Fig. 2: AB page 7	FRC:R14_30	{DF 1 B} Fig. 28: DF page 33
FRC:F60_B	{BG 1 B} Fig. 11: BG page 16	FRC:R14_85	{DF 1 C} Fig. 28: DF page 33
	{BH 1 B} Fig. 12: BH page 17	FRC:R14_86	{DF 1 B} Fig. 28: DF page 33
FRC:F61_B	{EA 2 B} Fig. 31: EA page 36	FRC:R14_87	{DF 1 C} Fig. 28: DF page 33
FRC:F62_B	{EA 2 B} Fig. 31: EA page 36	FRC:R2_30	{GB 1 B} Fig. 39: GB page 44
FRC:F63_B	{FD 2 A} Fig. 36: FD page 41	FRC:R2_85	{GB 1 B} Fig. 39: GB page 44
	{FB 4 A} Fig. 34: FB page 39	FRC:R2_86	{GB 0 B} Fig. 39: GB page 44
FRC:F64_B	{FD 3 A} Fig. 36: FD page 41	FRC:R2_87	{GB 1 B} Fig. 39: GB page 44
	{FB 3 A} Fig. 34: FB page 39	FRC:R3_30	{GB 2 B} Fig. 39: GB page 44
FRC:F65_B	{GA 1 B} Fig. 38: GA page 43	FRC:R3_85	{GB 2 B} Fig. 39: GB page 44
FRC:F66_A	{AB 2 D} Fig. 2: AB page 7		

FRC:R3_86	{GB 1 B} Fig. 39: GB page 44	MCAS1:B	{DB 1 C} Fig. 24: DB page 29
FRC:R3_87	{GB 2 B} Fig. 39: GB page 44	MCAS1:C	{DB 0 C} Fig. 24: DB page 29
FRC:R4_30	{BA 0 C} Fig. 5: BA page 10	MCAS1:D	{DB 0 C} Fig. 24: DB page 29
FRC:R4_85	{BA 0 B} Fig. 5: BA page 10	MCAS1:E	{DB 1 C} Fig. 24: DB page 29
FRC:R4_86	{BA 0 C} Fig. 5: BA page 10	MCAS1:F	{DB 1 C} Fig. 24: DB page 29
FRC:R4_87	{BA 0 B} Fig. 5: BA page 10	MCAS1:G	{DB 1 C} Fig. 24: DB page 29
FRC:R5_30	{FB 3 A} Fig. 34: FB page 39	MCAS1:H	{DB 1 C} Fig. 24: DB page 29
FRC:R5_85	{FB 2 B} Fig. 34: FB page 39	MCAS1:K	{DB 0 C} Fig. 24: DB page 29
FRC:R5_86	{FB 2 A} Fig. 34: FB page 39	MCAS1:L	{DB 2 C} Fig. 24: DB page 29
FRC:R5_87	{FB 3 B} Fig. 34: FB page 39	MCAS1:M	{DB 2 C} Fig. 24: DB page 29
FRC:R5_87A	{FB 3 B} Fig. 34: FB page 39	MCAS2:A	{DB 2 C} Fig. 24: DB page 29
FRC:R7_30	{DP 1 B} Fig. 30: DP page 35	MCAS2:B	{DB 2 C} Fig. 24: DB page 29
FRC:R7_85	{DP 1 B} Fig. 30: DP page 35	MCAS2:C	{DB 2 C} Fig. 24: DB page 29
FRC:R7_86	{DP 1 B} Fig. 30: DP page 35	MCAS2:D	{DB 2 C} Fig. 24: DB page 29
FRC:R7_87	{DP 1 B} Fig. 30: DP page 35	MCAS2:E	{DB 2 C} Fig. 24: DB page 29
FRC:R9_30	{MA 0 B} Fig. 69: MA page 74	MCAS2:F	{DB 2 C} Fig. 24: DB page 29
FRC:R9_85	{MA 0 B} Fig. 69: MA page 74	MCAS2:G	{DB 2 C} Fig. 24: DB page 29
FRC:R9_86	{MA 0 B} Fig. 69: MA page 74	MCAS2:H	{DB 2 C} Fig. 24: DB page 29
FRC:R9_87	{MA 0 B} Fig. 69: MA page 74	MCAS2:J	{DB 2 C} Fig. 24: DB page 29
LKDL:A	{IE 0 B} Fig. 60: IE page 65	MCAS3:A	{DG 2 C} Fig. 29: DG page 34
LKDL:B	{IE 0 B} Fig. 60: IE page 65	MCAS3:B	{DG 2 C} Fig. 29: DG page 34
LKDL:C	{IE 1 C} Fig. 60: IE page 65	MCAS3:D	{DG 1 C} Fig. 29: DG page 34
LKDL:D	{IE 0 C} Fig. 60: IE page 65	MCAS3:E	{DG 1 C} Fig. 29: DG page 34
LKDL:E	{IE 0 C} Fig. 60: IE page 65	MCAS3:F	{DG 1 C} Fig. 29: DG page 34
LKDR:A	{IE 1 C} Fig. 60: IE page 65	MCAS3:G	{DG 1 C} Fig. 29: DG page 34
LKDR:B	{IE 1 C} Fig. 60: IE page 65	MCAS3:H	{DG 1 C} Fig. 29: DG page 34
LKDR:C	{IE 1 C} Fig. 60: IE page 65	MCAS4:B	{DG 1 C} Fig. 29: DG page 34
MC141A:A	{GB 1 A} Fig. 39: GB page 44	MCAS4:D	{DG 1 B} Fig. 29: DG page 34
MC141A:B	{DP 2 B} Fig. 30: DP page 35	MCAS4:E	{DG 2 C} Fig. 29: DG page 34
MC141A:C	{JC 3 A} Fig. 65: JC page 70	MCAS4:F	{DG 2 C} Fig. 29: DG page 34
MC141A:D	{ID 2 A} Fig. 59: ID page 64	MCAS4:K	{DG 1 B} Fig. 29: DG page 34
MC141A:E	{DB 0 A} Fig. 24: DB page 29	MCAS4:L	{DG 2 C} Fig. 29: DG page 34
	{DE 1 A} Fig. 27: DE page 32	MCAS4:M	{DG 2 C} Fig. 29: DG page 34
MC141A:F	{FE 2 A} Fig. 37: FE page 42	MCAT1:A	{DE 0 D} Fig. 27: DE page 32
MC141A:G	{FB 0 A} Fig. 34: FB page 39	MCAT1:B	{DE 0 D} Fig. 27: DE page 32
MC141A:J	{HB 0 A} Fig. 50: HB page 55	MCAT1:C	{DE 0 D} Fig. 27: DE page 32
	{DE 2 A} Fig. 27: DE page 32	MCAT1:D	{DE 1 D} Fig. 27: DE page 32
MC141A:K	{GI 1 A} Fig. 46: GI page 51	MCAT1:E	{DE 0 D} Fig. 27: DE page 32
MC141A:L	{ID 1 A} Fig. 59: ID page 64	MCAT1:F	{DE 0 D} Fig. 27: DE page 32
MC141A-B:A	{GB 1 A} Fig. 39: GB page 44	MCAT1:G	{DE 3 C} Fig. 27: DE page 32
MC141A-B:B	{FD 1 A} Fig. 36: FD page 41	MCAT1:H	{DE 3 C} Fig. 27: DE page 32
	{FC 1 A} Fig. 35: FC page 40	MCAT1:J	{DE 0 D} Fig. 27: DE page 32
MC141A-B:C	{FD 2 A} Fig. 36: FD page 41	MCAT1:K	{DE 0 D} Fig. 27: DE page 32
	{FB 3 A} Fig. 34: FB page 39	MCAT1:L	{DE 1 D} Fig. 27: DE page 32
MC141A-B:D	{FD 2 A} Fig. 36: FD page 41	MCAT1:M	{DE 1 D} Fig. 27: DE page 32
	{FB 3 A} Fig. 34: FB page 39	MCAT1:N	{DE 1 D} Fig. 27: DE page 32
MC141A-B:E	{EA 3 A} Fig. 31: EA page 36	MCAT1:P	{DE 1 D} Fig. 27: DE page 32
MC141A-B:H	{CH 2 A} Fig. 21: CH page 26	MCAT1:R	{DE 1 D} Fig. 27: DE page 32
MCALS:A	{DE 1 B} Fig. 27: DE page 32	MCAT1:S	{DE 1 D} Fig. 27: DE page 32
MCALS:B	{DE 1 B} Fig. 27: DE page 32	MCAT2:A	{DF 1 C} Fig. 28: DF page 33
MCALS:C	{DE 1 B} Fig. 27: DE page 32	MCAT2:B	{DE 2 D} Fig. 27: DE page 32
MCALS:D	{DE 1 B} Fig. 27: DE page 32	MCAT2:C	{DE 2 D} Fig. 27: DE page 32
MCALS:E	{DE 1 B} Fig. 27: DE page 32	MCAT2:D	{DE 1 D} Fig. 27: DE page 32
MCALS:F	{DE 1 B} Fig. 27: DE page 32	MCAT2:E	{DE 1 D} Fig. 27: DE page 32
MCALS:G	{DE 1 B} Fig. 27: DE page 32	MCAT2:F	{DE 2 D} Fig. 27: DE page 32
MCALS:H	{DE 1 B} Fig. 27: DE page 32	MCAT2:G	{DE 3 D} Fig. 27: DE page 32
MCALS:J	{DE 1 B} Fig. 27: DE page 32	MCAT2:H	{DF 4 B} Fig. 28: DF page 33
MCALS:K	{DE 1 B} Fig. 27: DE page 32	MCAT2:J	{DF 3 B} Fig. 28: DF page 33
MCALS:L	{DE 1 B} Fig. 27: DE page 32	MCAT2:K	{DE 2 D} Fig. 27: DE page 32
MCALS:M	{DE 1 B} Fig. 27: DE page 32	MCAT2:L	{DE 3 D} Fig. 27: DE page 32
MCALS:N	{DE 1 B} Fig. 27: DE page 32	MCAT2:M	{DE 3 D} Fig. 27: DE page 32
MCALS:P	{DE 1 B} Fig. 27: DE page 32	MCAT2:N	{DE 3 D} Fig. 27: DE page 32
MCAS1:A	{DB 0 C} Fig. 24: DB page 29	MCAT2:P	{DE 2 D} Fig. 27: DE page 32

MCAT2:R	MEB13D Fig. 27 DE page 32	page	
MCAT2:S	{DE 0 D} Fig. 27 DE page 32	page	
MCBB:A	{BI 1 B} Fig. 13: BF page 11	page	
MCBB:B	MEB13D Fig. 13: BF page 11	page	
MCBOC:A	{GG 2 B} Fig. 44 CG page 49	page	
	{GG 1 C} Fig. 44 CG page 49	page	
	MEB13E Fig. 44 CG page 49	page	
MCBOC:B	MEB13F Fig. 44 BKE page 49	page	
	MEB13G Fig. 44 BKE page 49	page	
	MEBR2A Fig. 44 CG page 49	page	
MCCB:A	{IF 3 C} Fig. 61: CF	page 66	B) Fig. page
MCCB:B	{IF 3 D} Fig. 61: CF	page 66	B) Fig. page
MCDL2:A	{IC 2 B} Fig. 58: CF	page 63	B) Fig. page
	MEBR2B Fig. 59: CF page 64	page	
MCDL2:B	{IC 1 B} Fig. 58: CF page 63	page	
MCDL2:C	{IC 1 C} Fig. 58: CF	page 63	D) Fig. page
MCDL2:D	{IC 1 B} Fig. 58: CF	page 63	D) Fig. page
MCDL2:E	MFC2BA Fig. 58: BA	page 63	C) page AB
	MFC2CA Fig. 59: CD page 64	page	
MCDL2:F	MFC2BA Fig. 58: BA	page 63	
MCDL2:G	MFC2BA Fig. 58: BA	page 63	
	MFC2CA Fig. 59: CD page 64	page	
MCDL2:H	MFC2CA Fig. 59: CD page 64	page	
	MFC2CA Fig. 58: CE page 63	page	
MCDL3:A	{IC 1 B} Fig. 58: CE	page 63	පිහිටු.
	{ID 2 B} Fig. 59: CE	page 64	පිහිටු.
MCDL3:B	MFC2CA Fig. 58: CE	page 63	පිහිටු.
MCDL3:D	{IA 1 C} Fig. 56: CE	page 61	පිහිටු.
MCDL3:E	{IA 1 C} Fig. 56: CE	page 61	පිහිටු.
MCDL3:F	MEC315A Fig. 3: CD	page 8	B) Fig. page
	MFC2DA Fig. 59: CD	page 64	B) Fig. page
MCDL3:G	MFC2BA Fig. 56: CD	page 61	B) Fig. page
	MFC2DA Fig. 56: CD	page 61	B) Fig. page
	MFC2DA Fig. 56: BD page 65	Fig BDe page	
MCDL4:A	MFC02A Fig. 66: MA	page 71	C) Fig. page
	MEC020A Fig. 67: BKE	page 72	BDe page
	MEC020A Fig. 68: BKC	page 73	BDe page
MCDL4:B	MFC022A Fig. 66: BKC	page 71	BDe page
	MEC023A Fig. 67: GB	page 72	B) Fig. page
	MEC024A Fig. 68: GA	page 73	B) Fig. page
MCDL5:B	MFC25A Fig. 56: GA	page 61	පිහිටු.
	MFC25A Fig. 56: GA	page 61	පිහිටු.
MCDL5:F	MFC27A Fig. 56: GA	page 61	පිහිටු.
MCDR2:A	MFC28A Fig. 56: BB	page 61	B) Fig. page
	MFC29A Fig. 56: BK	page 65	Fig BBe
MCDR2:B	MEC23A Fig. 3: SB	page 8	B) Fig. page
	MFC30A Fig. 59: HA	page 64	B) Fig. page
MCDR2:C	MFC31A Fig. 56: FA	page 65	B) Fig. page
MCDR2:D	MFC32A Fig. 58: KA	page 63	B) Fig. page
MCDR2:E	MFC33A Fig. 58: XA	page 65	B) Fig. page
MCDR2:F	MFC34A Fig. 60: XA	page 65	D) Fig. page
	MFC35A Fig. 56: CD	page 61	B) Fig. page
MCDR3:A	MFC36A Fig. 68: KA	page 71	B) Fig. page
	MEC237A Fig. 67: BKB	page 72	පිහිටු.
	MEC038A Fig. 68: FBe	page 73	C) Fig. page
MCRL3:B	{ [(IC)-0 D] Fig. 60: KA	page 71	page
	{KB 2 D} Fig. 67: FB	page 72	page
	{KC 0 D} Fig. 68: FBe	page 73	page
MCDL5:F	{IA FBe 1 C} Fig.	page	E) Fig. 56: IA page 61
MCD53:G	MFC39A Fig. 56: FA	page 65	page
MEB13:A	BAB 4 D} Fig. AB	page	
MEB13:B	CFe		B) Fig. page

MCFC:4	{MA 1 C} Fig. 69: MA page 74	MCFC:80	{GP 1 D} Fig. 47: GP page 52
MCFC:40	{EA 3 C} Fig. 31: EA page 36	MCFC:81	{GP 2 D} Fig. 47: GP page 52
MCFC:41	{FD 1 C} Fig. 36: FD page 41	MCFC:82	{GP 2 B} Fig. 47: GP page 52
	{FD 0 C} Fig. 36: FD page 41	MCFC:83	{XA 3 C} Fig. 71: XA page 76
	{FC 1 C} Fig. 35: FC page 40	MCFC:84	{XA 3 C} Fig. 71: XA page 76
	{FC 1 C} Fig. 35: FC page 40	MCFC:87	{FB 3 D} Fig. 34: FB page 39
MCFC:42	{FD 0 C} Fig. 36: FD page 41		{FB 1 D} Fig. 34: FB page 39
	{FD 2 C} Fig. 36: FD page 41		{FB 1 C} Fig. 34: FB page 39
	{FD 2 C} Fig. 36: FD page 41	MCFC:9	{GQ 0 D} Fig. 48: GQ page 53
	{FB 3 C} Fig. 34: FB page 39	MCFC:95	{GD 0 A} Fig. 41: GD page 46
MCFC:44	{JB 0 D} Fig. 64: JB page 69	MCFC:96	{MA 1 C} Fig. 69: MA page 74
	{FB 2 D} Fig. 34: FB page 39	MCFC:97	{GA 2 D} Fig. 38: GA page 43
	{FB 1 D} Fig. 34: FB page 39	MCFC:98	{MA 0 C} Fig. 69: MA page 74
	{FB 1 C} Fig. 34: FB page 39	MCFC:99	{AC 0 B} Fig. 3: AC page 8
	{EB 1 B} Fig. 32: EB page 37	MCLA:A	{FB 3 B} Fig. 34: FB page 39
MCFC:45	{JB 1 D} Fig. 64: JB page 69	MCLA:B	{FB 0 C} Fig. 34: FB page 39
	{FB 2 C} Fig. 34: FB page 39	MCLA:C	{FB 1 C} Fig. 34: FB page 39
	{EB 1 B} Fig. 32: EB page 37	MCLA:D	{FB 2 C} Fig. 34: FB page 39
MCFC:46	{CB 0 C} Fig. 17: CB page 22	MCLA:E	{FB 1 C} Fig. 34: FB page 39
MCFC:47	{FB 2 D} Fig. 34: FB page 39	MCLA:F	{FB 0 B} Fig. 34: FB page 39
	{FB 1 D} Fig. 34: FB page 39	MCLA:G	{FB 0 C} Fig. 34: FB page 39
	{FB 1 C} Fig. 34: FB page 39	MCLA:H	{FB 0 B} Fig. 34: FB page 39
MCFC:48	{MA 1 C} Fig. 69: MA page 74	MCLK:A	{IE 1 B} Fig. 60: IE page 65
MCFC:49	{MA 0 C} Fig. 69: MA page 74	MCLK:B	{IE 1 B} Fig. 60: IE page 65
MCFC:5	{CE 0 B} Fig. 19: CE page 24	MCLK:C	{IE 1 B} Fig. 60: IE page 65
MCFC:50	{DP 4 D} Fig. 30: DP page 35	MCLK:D	{IE 1 B} Fig. 60: IE page 65
	{JB 0 D} Fig. 64: JB page 69	MCLK:E	{IE 1 B} Fig. 60: IE page 65
	{EB 1 B} Fig. 32: EB page 37	MCMC1:A	{CC 1 C} Fig. 18: CC page 22
MCFC:51	{JB 1 D} Fig. 64: JB page 69	MCMC1:D	{CB 1 B} Fig. 17: CB page 22
	{FE 3 B} Fig. 37: FE page 42	MCMC2:C	{BA 4 C} Fig. 5: BA page 10
	{EB 1 B} Fig. 32: EB page 37		{BA 3 C} Fig. 5: BA page 10
MCFC:52	{JB 2 D} Fig. 64: JB page 69		{BA 4 C} Fig. 5: BA page 10
	{FE 3 C} Fig. 37: FE page 42	MCMJ1:A	{IC 4 C} Fig. 58: IC page 63
	{EB 2 D} Fig. 32: EB page 37		{ID 4 D} Fig. 59: ID page 64
MCFC:53	{JB 0 D} Fig. 64: JB page 69	MCMJ2:A	{IC 2 D} Fig. 58: IC page 63
	{FE 2 C} Fig. 37: FE page 42		{ID 3 D} Fig. 59: ID page 64
	{EB 2 D} Fig. 32: EB page 37	MCMJ2:B	{IC 3 B} Fig. 58: IC page 63
MCFC:54	{AC 3 D} Fig. 3: AC page 8		{ID 3 D} Fig. 59: ID page 64
MCFC:55	{AC 3 D} Fig. 3: AC page 8	MCMJ2:C	{IC 3 B} Fig. 58: IC page 63
MCFC:56	{JB 0 D} Fig. 64: JB page 69	MCMJ2:D	{IC 3 B} Fig. 58: IC page 63
	{EB 2 D} Fig. 32: EB page 37		{ID 4 C} Fig. 59: ID page 64
MCFC:57	{FE 1 C} Fig. 37: FE page 42	MCMJ3:A	{IC 1 D} Fig. 58: IC page 63
MCFC:58	{DP 0 C} Fig. 30: DP page 35		{ID 2 D} Fig. 59: ID page 64
MCFC:59	{CH 2 D} Fig. 21: CH page 26	MCMJ3:B	{IC 1 B} Fig. 58: IC page 63
MCFC:6	{FA 2 A} Fig. 33: FA page 38	MCMJ3:C	{IC 1 B} Fig. 58: IC page 63
MCFC:61	{BD 1 C} Fig. 8: BD page 13	MCMJ3:D	{IC 1 B} Fig. 58: IC page 63
MCFC:63	{BC 2 C} Fig. 7: BC page 12	MCMJ4:A	{IC 0 C} Fig. 58: IC page 63
MCFC:64	{BC 2 C} Fig. 7: BC page 12		{ID 2 D} Fig. 59: ID page 64
MCFC:65	{BG 3 C} Fig. 11: BG page 16	MCOF1:A	{IA 1 C} Fig. 56: IA page 61
MCFC:66	{AD 2 B} Fig. 4: AD page 9	MCOF1:B	{IA 0 C} Fig. 56: IA page 61
MCFC:67	{CB 2 B} Fig. 17: CB page 22	MCOF1:C	{GC 2 C} Fig. 40: GC page 45
MCFC:68	{CB 1 B} Fig. 17: CB page 22		{GC 2 B} Fig. 40: GC page 45
MCFC:7	{EA 2 B} Fig. 31: EA page 36	MCOF1:D	{AC 3 B} Fig. 3: AC page 8
MCFC:71	{BC 3 C} Fig. 7: BC page 12	MCOF1:E	{IA 0 C} Fig. 56: IA page 61
MCFC:72	{CC 1 C} Fig. 18: CC page 23	MCPL:A	{GI 2 C} Fig. 46: GI page 51
	{CI 3 C} Fig. 22: CI page 27	MCPL:B	{GI 0 D} Fig. 46: GI page 51
MCFC:75	{GI 1 D} Fig. 46: GI page 51	MCPL:C	{GI 2 C} Fig. 46: GI page 51
MCFC:76	{GI 1 D} Fig. 46: GI page 51	MCPL:D	{GI 1 B} Fig. 46: GI page 51
MCFC:77	{GI 1 D} Fig. 46: GI page 51	MCPL:E	{GI 1 B} Fig. 46: GI page 51
MCFC:78	{GP 1 C} Fig. 47: GP page 52	MCPL:F	{GI 1 B} Fig. 46: GI page 51
MCFC:79	{GP 3 B} Fig. 47: GP page 52	MCPL:G	{GI 0 D} Fig. 46: GI page 51
	{GI 1 D} Fig. 46: GI page 51	MCPL:H	{GI 3 B} Fig. 46: GI page 51
MCFC:8	{EA 2 B} Fig. 31: EA page 36	MCPL2:A	{GI 1 C} Fig. 46: GI page 51

MCPL2:B	{GI 1 C} Fig. 46: GI page 51	MCSL5:C	{HB 2 C} Fig. 50: HB page 55
MCPL2:C	{GI 1 C} Fig. 46: GI page 51	MCSL6:A	{GH 0 B} Fig. 45: GH page 50
MCPL2:D	{GI 1 C} Fig. 46: GI page 51		{GH 2 B} Fig. 45: GH page 50
MCPTO1:A	{DP 1 C} Fig. 30: DP page 35		{GH 0 B} Fig. 45: GH page 50
	{DP 1 C} Fig. 30: DP page 35	MCSL6:B	{GH 0 D} Fig. 45: GH page 50
MCPTO1:B	{DP 3 A} Fig. 30: DP page 35		{GH 2 D} Fig. 45: GH page 50
MCPTO1:C	{DP 3 D} Fig. 30: DP page 35		{GH 0 D} Fig. 45: GH page 50
MCPTO1:D	{DP 4 C} Fig. 30: DP page 35	MCSL7:A	{IG 3 C} Fig. 62: IG page 67
MCPTO2:A	{DP 2 D} Fig. 30: DP page 35	MCSW:A	{JC 0 B} Fig. 65: JC page 70
MCPW:D	{ID 1 B} Fig. 59: ID page 64	MCSW:B	{JC 2 B} Fig. 65: JC page 70
MCPW:F	{IA 3 B} Fig. 56: IA page 61	MCSW:C	{JC 2 C} Fig. 65: JC page 70
MCQC:A	{BE 1 B} Fig. 9: BE page 14	MCSW:D	{JC 1 B} Fig. 65: JC page 70
MCQC:B	{BE 0 B} Fig. 9: BE page 14	MCSW:E	{GA 3 B} Fig. 38: GA page 43
MCRS:A	{IF 2 C} Fig. 61: IF page 66		{JC 4 D} Fig. 65: JC page 70
MCRS:B	{IF 3 C} Fig. 61: IF page 66		{JC 0 C} Fig. 65: JC page 70
MCRSO:A	{GC 1 B} Fig. 40: GC page 45	MCSW:F	{GA 3 C} Fig. 38: GA page 43
MCRSO:B	{GC 1 B} Fig. 40: GC page 45		{JC 3 D} Fig. 65: JC page 70
MCRSO:C	{GC 2 B} Fig. 40: GC page 45		{JC 0 C} Fig. 65: JC page 70
MCRSO:D	{GC 1 B} Fig. 40: GC page 45	MCSW:G	{GA 3 C} Fig. 38: GA page 43
MCRSO:E	{GC 1 B} Fig. 40: GC page 45		{JC 1 C} Fig. 65: JC page 70
MCRW:A	{KB 1 D} Fig. 67: KB page 72	MCSW:H	{JC 3 B} Fig. 65: JC page 70
MCRW:B	{KB 1 D} Fig. 67: KB page 72	MCTLK1:C	{BA 4 C} Fig. 5: BA page 10
MCRW:C	{KB 1 D} Fig. 67: KB page 72	MCTLK2:C	{BA 4 C} Fig. 5: BA page 10
MCRW:D	{KB 1 D} Fig. 67: KB page 72	MCTR1:A	{DB 3 C} Fig. 24: DB page 29
MCSL1:B	{HB 2 D} Fig. 50: HB page 55		{DC 0 B} Fig. 25: DC page 30
	{HG 1 D} Fig. 55: HG page 60	MCTR1:B	{DB 3 C} Fig. 24: DB page 29
MCSL1:C	{HB 2 B} Fig. 50: HB page 55		{DC 0 B} Fig. 25: DC page 30
	{HG 1 B} Fig. 55: HG page 60		{DD 1 B} Fig. 26: DD page 31
MCSL1:D	{HB 3 B} Fig. 50: HB page 55	MCTR1:C	{GA 2 C} Fig. 38: GA page 43
	{HG 3 B} Fig. 55: HG page 60	MCTR1:D	{BC 4 C} Fig. 7: BC page 12
MCSL1:E	{HB 2 B} Fig. 50: HB page 55	MCTR1:E	{BB 0 C} Fig. 6: BB page 11
MCSL1:F	{HD 1 D} Fig. 52: HD page 57	MCTR1:F	{BB 0 C} Fig. 6: BB page 11
	{HE 2 D} Fig. 53: HE page 58	MCTR1:G	{DB 3 C} Fig. 24: DB page 29
	{HF 2 D} Fig. 54: HF page 59		{DC 1 D} Fig. 25: DC page 30
MCSL1:H	{HB 0 C} Fig. 50: HB page 55	MCTR1:H	{DB 3 C} Fig. 24: DB page 29
MCSL1:J	{HB 0 C} Fig. 50: HB page 55		{DC 1 D} Fig. 25: DC page 30
MCSL1:L	{HD 0 D} Fig. 52: HD page 57	MCTR1:J	{BC 4 C} Fig. 7: BC page 12
	{HE 1 D} Fig. 53: HE page 58	MCTR1:K	{GA 2 C} Fig. 38: GA page 43
	{HG 3 C} Fig. 55: HG page 60	MCTR1:L	{DC 0 D} Fig. 25: DC page 30
MCSL1:M	{BA 4 B} Fig. 5: BA page 10		{DD 1 D} Fig. 26: DD page 31
MCSL2:A	{KB 0 B} Fig. 67: KB page 72	MCTR1:M	{DC 1 D} Fig. 25: DC page 30
	{KB 0 D} Fig. 67: KB page 72	MCTR2:A	{DB 3 C} Fig. 24: DB page 29
	{KC 2 C} Fig. 68: KC page 73	MCTR2:B	{DB 3 C} Fig. 24: DB page 29
MCSL2:B	{KB 1 B} Fig. 67: KB page 72	MCTR2:C	{DB 3 C} Fig. 24: DB page 29
	{KB 0 D} Fig. 67: KB page 72	MCTR2:D	{DB 3 C} Fig. 24: DB page 29
	{KC 2 C} Fig. 68: KC page 73	MCTR2:E	{DB 3 C} Fig. 24: DB page 29
MCSL2:C	{KB 0 B} Fig. 67: KB page 72	MCTR2:F	{DB 2 B} Fig. 24: DB page 29
	{KB 0 D} Fig. 67: KB page 72	MCTR2:G	{DB 2 B} Fig. 24: DB page 29
	{KC 3 C} Fig. 68: KC page 73	MCTR3:A	{DG 1 D} Fig. 29: DG page 34
MCSL2:D	{KB 0 B} Fig. 67: KB page 72	MCTR3:B	{DG 1 D} Fig. 29: DG page 34
	{KB 0 D} Fig. 67: KB page 72	MCTR3:C	{DG 1 D} Fig. 29: DG page 34
	{KC 3 C} Fig. 68: KC page 73	MCTR3:H	{DG 1 C} Fig. 29: DG page 34
MCSL3:A	{HB 0 C} Fig. 50: HB page 55	MCTR4:A	{DG 2 D} Fig. 29: DG page 34
MCSL3:C	{AB 0 C} Fig. 2: AB page 7	MCTR4:B	{DG 2 D} Fig. 29: DG page 34
MCSL3:D	{HD 0 B} Fig. 52: HD page 57	MCTR4:D	{DG 1 D} Fig. 29: DG page 34
	{HE 2 D} Fig. 53: HE page 58	MCTR4:E	{DG 1 D} Fig. 29: DG page 34
MCSL3:E	{HD 0 B} Fig. 52: HD page 57	MCTR4:F	{DG 2 D} Fig. 29: DG page 34
	{HE 2 D} Fig. 53: HE page 58	MCTR4:G	{DG 2 D} Fig. 29: DG page 34
MCSL3:F	{HB 1 B} Fig. 50: HB page 55	MCUS1:A	{DB 2 B} Fig. 24: DB page 29
MCSL3:G	{HB 1 C} Fig. 50: HB page 55	MCUS1:B	{DB 3 B} Fig. 24: DB page 29
MCSL3:H	{HB 1 C} Fig. 50: HB page 55		{DB 2 B} Fig. 24: DB page 29
MCSL5:B	{HB 1 B} Fig. 50: HB page 55		{DB 1 C} Fig. 24: DB page 29
	{HF 2 B} Fig. 54: HF page 59		

MCUS1:C	{DB 3 B} Fig. 24: DB page 29	PM2:1	{AB 3 B} Fig. 2: AB page 7
	{DB 2 B} Fig. 24: DB page 29	PM3:1	{AB 1 D} Fig. 2: AB page 7
	{DB 1 C} Fig. 24: DB page 29	PM3:2	{AA 0 B} Fig. 1: AA page 6
MCUS2:A	{DB 2 A} Fig. 24: DB page 29	PM4:1	{AA 1 C} Fig. 1: AA page 6
MCUS2:D	{DB 3 A} Fig. 24: DB page 29	PM4:2	{AB 1 A} Fig. 2: AB page 7
MCVE:A	{JB 2 B} Fig. 64: JB page 69	PM5:1	{AB 4 C} Fig. 2: AB page 7
	{EB 3 C} Fig. 32: EB page 37	PM5:2	{AA 1 D} Fig. 1: AA page 6
MCVE:A	{JB 2 B} Fig. 64: JB page 69	PM6:1	{AA 2 B} Fig. 1: AA page 6
	{EB 3 C} Fig. 32: EB page 37	PM6:2	{AB 3 C} Fig. 2: AB page 7
MCVE:B	{JB 3 B} Fig. 64: JB page 69	PM7:1	{HB 2 B} Fig. 50: HB page 55
	{EB 4 D} Fig. 32: EB page 37		{BG 0 B} Fig. 11: BG page 16
MCVE:C	{JB 2 C} Fig. 64: JB page 69	PM7:2	{AA 1 D} Fig. 1: AA page 6
MCVE:D	{JB 2 D} Fig. 64: JB page 69	PM7:3	{MA 0 B} Fig. 69: MA page 74
	{EB 2 C} Fig. 32: EB page 37	PM7:4	{HB 1 B} Fig. 50: HB page 55
MCVE:E	{JB 1 B} Fig. 64: JB page 69		{HF 2 B} Fig. 54: HF page 59
	{EB 2 C} Fig. 32: EB page 37	PM8:1	{AA 1 B} Fig. 1: AA page 6
MCVE:F	{JB 1 D} Fig. 64: JB page 69	PM8:2	{GB 3 B} Fig. 39: GB page 44
	{EB 1 C} Fig. 32: EB page 37	PM8:3	{HB 2 B} Fig. 50: HB page 55
MCVE:G	{JB 0 C} Fig. 64: JB page 69		{HG 1 A} Fig. 55: HG page 60
	{EB 2 C} Fig. 32: EB page 37	PM8:4	{HB 3 B} Fig. 50: HB page 55
MCVE:H	{JB 0 C} Fig. 64: JB page 69		{HG 3 B} Fig. 55: HG page 60
	{EB 2 C} Fig. 32: EB page 37	PM9:1	{AB 1 C} Fig. 2: AB page 7
MCVE:J	{JB 0 C} Fig. 64: JB page 69	PM9:2	{AB 2 D} Fig. 2: AB page 7
	{EB 1 C} Fig. 32: EB page 37	PM9:4	{AA 2 C} Fig. 1: AA page 6
MCVE:K	{JB 0 C} Fig. 64: JB page 69	PM9:6	{AB 1 C} Fig. 2: AB page 7
	{EB 1 C} Fig. 32: EB page 37	PM9:7	{AA 1 C} Fig. 1: AA page 6
MCVE:L	{EB 4 B} Fig. 32: EB page 37	PM9:8	{AB 0 C} Fig. 2: AB page 7
OBTBJ:A	{HD 3 C} Fig. 52: HD page 57	PSOF:A	{KC 2 C} Fig. 68: KC page 73
OBTBJ:C	{HD 3 E} Fig. 52: HD page 57	PSOF:B	{KC 2 C} Fig. 68: KC page 73
OFRFJ:A	{GC 1 C} Fig. 40: GC page 45	PSOF:C	{KC 3 C} Fig. 68: KC page 73
OFRFJ:B	{GC 1 D} Fig. 40: GC page 45	PSOF:D	{KC 3 C} Fig. 68: KC page 73
OFRS:A	{IF 2 D} Fig. 61: IF page 66	PSOF:E	{KC 1 C} Fig. 68: KC page 73
OFSL:A	{KC 2 D} Fig. 68: KC page 73	PSOF:F	{KC 1 C} Fig. 68: KC page 73
OFSL:B	{KC 2 D} Fig. 68: KC page 73	PSOF:G	{KC 1 C} Fig. 68: KC page 73
OFSL:C	{KC 2 D} Fig. 68: KC page 73	PSOF:H	{KC 1 C} Fig. 68: KC page 73
OFSL:D	{KC 2 D} Fig. 68: KC page 73	PSOF:J	{KC 0 B} Fig. 68: KC page 73
OFSL:E	{KC 3 D} Fig. 68: KC page 73	PSOF2:A	{KC 1 C} Fig. 68: KC page 73
OFSL:F	{KC 3 D} Fig. 68: KC page 73	PSOF2:B	{KC 1 C} Fig. 68: KC page 73
OFSL:G	{KC 3 D} Fig. 68: KC page 73	PSOF2:C	{KC 2 C} Fig. 68: KC page 73
OFSL:H	{KC 3 D} Fig. 68: KC page 73	PSOF2:D	{KC 2 C} Fig. 68: KC page 73
OFSV:1	{GC 2 C} Fig. 40: GC page 45	PSOF2:E	{KC 0 C} Fig. 68: KC page 73
OFSV:2	{GC 2 D} Fig. 40: GC page 45	PSOF2:F	{KC 1 C} Fig. 68: KC page 73
OPT1:A	{BF 3 C} Fig. 10: BF page 15	PSOF2:G	{KC 1 C} Fig. 68: KC page 73
OPT1:B	{BF 3 B} Fig. 10: BF page 15	PSOF2:H	{KC 1 C} Fig. 68: KC page 73
OPT1587:A	{XA 1 B} Fig. 71: XA page 76	PWDR:B	{ID 0 D} Fig. 59: ID page 64
OPT1587:B	{XA 0 B} Fig. 71: XA page 76	PWDR:D	{ID 0 D} Fig. 59: ID page 64
OPT2:A	{BH 1 D} Fig. 12: BH page 17	PWDR:E	{ID 0 D} Fig. 59: ID page 64
OPT2:B	{BH 1 D} Fig. 12: BH page 17	PWDR:F	{IA 3 B} Fig. 56: IA page 61
OPT3:A	{BI 3 A} Fig. 13: BI page 18	RADLR:A	{BD 2 B} Fig. 8: BD page 13
OPT3:B	{BI 3 A} Fig. 13: BI page 18	RADLR:B	{BD 2 B} Fig. 8: BD page 13
OPT4:A	{BE 1 D} Fig. 9: BE page 14	RADJLR:A	{BD 2 B} Fig. 8: BD page 13
OPT4:B	{BE 1 D} Fig. 9: BE page 14	RADJLR:B	{BD 2 B} Fig. 8: BD page 13
OPT5:1	{XA 3 A} Fig. 71: XA page 76	RFJRF:A	{GC 0 C} Fig. 40: GC page 45
OPT5:2	{XA 3 A} Fig. 71: XA page 76	RFJRF:B	{GC 0 D} Fig. 40: GC page 45
OPT6:A	{JB 3 D} Fig. 64: JB page 69	RJMC:A	{KA 0 C} Fig. 66: KA page 71
OPT6:B	{JB 2 D} Fig. 64: JB page 69		{KB 3 D} Fig. 67: KB page 72
OPT7:A	{EB 2 B} Fig. 32: EB page 37		{KC 0 D} Fig. 68: KC page 73
OPT7:B	{EB 2 B} Fig. 32: EB page 37	RJMC:B	{KA 1 C} Fig. 66: KA page 71
OPT8:A	{BK 2 D} Fig. 15: BK page 20		{KB 2 D} Fig. 67: KB page 72
OPT8:B	{BK 2 D} Fig. 15: BK page 20	RJMC:C	{KC 1 D} Fig. 68: KC page 73
PLSPO:A	{GI 3 D} Fig. 46: GI page 51		{KA 1 B} Fig. 66: KA page 71
PLSPO:B	{GI 3 B} Fig. 46: GI page 51		{KB 2 B} Fig. 67: KB page 72
PM1:1	{AA 1 B} Fig. 1: AA page 6		{KC 2 A} Fig. 68: KC page 73

RJMC:D	{KA 0 B} Fig. 66: KA page 71 {KB 2 B} Fig. 67: KB page 72 {KC 0 B} Fig. 68: KC page 73	SLOB:A	{HD 3 C} Fig. 52: HD page 57
RJMC:E	{KA 1 C} Fig. 66: KA page 71 {KB 3 D} Fig. 67: KB page 72 {KC 1 D} Fig. 68: KC page 73	SLOB:B	{HD 3 C} Fig. 52: HD page 57
RJMC:F	{KA 1 C} Fig. 66: KA page 71 {KB 2 D} Fig. 67: KB page 72 {KC 2 D} Fig. 68: KC page 73	SLOB:C	{HD 1 B} Fig. 52: HD page 57
RJMC:G	{KA 1 C} Fig. 66: KA page 71 {KB 4 D} Fig. 67: KB page 72 {KC 1 D} Fig. 68: KC page 73	SLOB:D	{HD 2 B} Fig. 52: HD page 57
RJMC:H	{KA 1 C} Fig. 66: KA page 71 {KB 2 D} Fig. 67: KB page 72 {KC 1 D} Fig. 68: KC page 73	SLOB:E	{HD 1 B} Fig. 52: HD page 57
RJMC:I	{KA 2 C} Fig. 66: KA page 71 {KB 4 C} Fig. 67: KB page 72 {KC 4 C} Fig. 68: KC page 73	SLOB:F	{HD 2 D} Fig. 52: HD page 57
RJMC:J	{KA 1 B} Fig. 66: KA page 71 {KB 3 B} Fig. 67: KB page 72 {KC 2 A} Fig. 68: KC page 73	SLOB:G	{KB 0 B} Fig. 67: KB page 72
RJMC:K	{KA 1 B} Fig. 66: KA page 71 {KB 2 B} Fig. 67: KB page 72 {KC 1 A} Fig. 68: KC page 73	SLOB:H	{KB 1 B} Fig. 67: KB page 72
RJMC:L	{KA 2 C} Fig. 66: KA page 71 {KB 3 D} Fig. 67: KB page 72 {KC 1 D} Fig. 68: KC page 73	SLOB:J	{KB 0 B} Fig. 67: KB page 72
RJMC:M	{KA 1 C} Fig. 66: KA page 71 {KB 2 D} Fig. 67: KB page 72 {KC 2 D} Fig. 68: KC page 73	SLOB:K	{KB 0 B} Fig. 67: KB page 72
RJMC2:A	{KB 1 C} Fig. 67: KB page 72 {KC 2 C} Fig. 68: KC page 73	SLOB:L	{IG 2 B} Fig. 62: IG page 67
RJMC2:B	{KB 1 C} Fig. 67: KB page 72 {KC 3 C} Fig. 68: KC page 73	SLOB:M	{IG 3 B} Fig. 62: IG page 67
RJMC2:C	{KB 1 C} Fig. 67: KB page 72 {KC 2 C} Fig. 68: KC page 73	SLRH:A	{KC 3 C} Fig. 68: KC page 73
RJMC2:D	{KB 1 D} Fig. 67: KB page 72 {KC 3 C} Fig. 68: KC page 73	SLRH:B	{KC 3 C} Fig. 68: KC page 73
RSCB:A	{IF 3 C} Fig. 61: IF page 66	SLRH:C	{KC 2 C} Fig. 68: KC page 73
RSCB:B	{IF 3 D} Fig. 61: IF page 66	SLRH:D	{KC 2 C} Fig. 68: KC page 73
RSOOF:A	{GC 1 B} Fig. 40: GC page 45	SLRW:A	{HE 4 D} Fig. 53: HE page 58
RSOOF:B	{GC 1 B} Fig. 40: GC page 45	SLRW:B	{GH 2 B} Fig. 45: GH page 50
RSOOF:C	{GC 2 B} Fig. 40: GC page 45	SLRW:C	{GH 2 D} Fig. 45: GH page 50
RSOOF:D	{GC 1 B} Fig. 40: GC page 45	SLSK:A	{HE 0 B} Fig. 53: HE page 58
RSOOF:E	{GC 1 B} Fig. 40: GC page 45	SLSK:B	{HE 1 E} Fig. 53: HE page 58
RWBPOC:A	{GH 2 B} Fig. 45: GH page 50 {GH 3 B} Fig. 45: GH page 50 {GH 3 B} Fig. 45: GH page 50	SLVA:A	{HE 3 B} Fig. 53: HE page 58
RWBPOC:B	{GH 3 D} Fig. 45: GH page 50 {GH 2 D} Fig. 45: GH page 50 {GH 3 D} Fig. 45: GH page 50	SLVA:B	{HE 3 B} Fig. 53: HE page 58
SLBOC:A	{GH 1 B} Fig. 45: GH page 50 {GH 1 B} Fig. 45: GH page 50 {GH 0 B} Fig. 45: GH page 50	SLVA:C	{HE 3 C} Fig. 53: HE page 58
SLBOC:B	{GH 0 C} Fig. 45: GH page 50 {GH 1 C} Fig. 45: GH page 50 {GH 1 D} Fig. 45: GH page 50	TETL:A	{GF 2 A} Fig. 43: GF page 48
		TETL:B	{GF 2 A} Fig. 43: GF page 48
		TETL:C	{GF 0 A} Fig. 43: GF page 48
		TETL:D	{GF 0 A} Fig. 43: GF page 48
		TETL:E	{GF 1 C} Fig. 43: GF page 48
		TLTL:A	{GF 3 B} Fig. 43: GF page 48
		TLTL:B	{GF 3 B} Fig. 43: GF page 48
		TLTL:C	{GF 2 C} Fig. 43: GF page 48
		TLTL:D	{GF 2 B} Fig. 43: GF page 48
		TLTL:E	{GF 2 B} Fig. 43: GF page 48
		TRSN:A	{DC 2 D} Fig. 25: DC page 30
		TRSN:B	{DC 2 D} Fig. 25: DC page 30
		TRSN:C	{DC 2 D} Fig. 25: DC page 30
		TRTBP:A	{DB 4 C} Fig. 24: DB page 29
		TRTBP:B	{DG 0 C} Fig. 29: DG page 34
		TRTBP:C	{DF 3 D} Fig. 28: DF page 33
			{DB 4 E} Fig. 24: DB page 29
			{DG 0 C} Fig. 29: DG page 34
			{DF 4 D} Fig. 28: DF page 33
			{DF 3 D} Fig. 28: DF page 33

Reference List: Physical Splice Connectors

S131B	{HF 2 C} Fig. 54: HF page 59	SP0C-7	{AA 3 E} Fig. 1: AA page 6 {IE 1 E} Fig. 60: IE page 65 {AC 2 B} Fig. 3: AC page 8 {IC 3 E} Fig. 58: IC page 63 {IA 2 E} Fig. 56: IA page 61 {IA 1 E} Fig. 56: IA page 61
SP0	{AC 1 C} Fig. 3: AC page 8	SP0C-7_1	{AC 2 C} Fig. 3: AC page 8 {MA 0 E} Fig. 69: MA page 74 {GB 3 E} Fig. 39: GB page 44
SP0_1	{AC 3 D} Fig. 3: AC page 8 {NA 2 E} Fig. 70: NA page 75 {ID 3 E} Fig. 59: ID page 64	SP0C-9	{IE 0 E} Fig. 60: IE page 65 {AC 2 D} Fig. 3: AC page 8 {IA 2 E} Fig. 56: IA page 61 {IA 2 E} Fig. 56: IA page 61
SP0A	{GH 0 D} Fig. 45: GH page 50	SP0C-DL	{AC 2 D} Fig. 3: AC page 8 {IA 3 C} Fig. 56: IA page 61 {IA 3 E} Fig. 56: IA page 61
SP0A_1	{GH 2 D} Fig. 45: GH page 50	SP0C-DR	{AC 2 B} Fig. 3: AC page 8 {IA 4 E} Fig. 56: IA page 61
SP0-B	{GF 1 D} Fig. 43: GF page 48	SP0C-MD	{ID 3 D} Fig. 59: ID page 64
SP0B	{HD 0 E} Fig. 52: HD page 57 {HB 0 E} Fig. 50: HB page 55 {HB 2 E} Fig. 50: HB page 55 {AC 3 D} Fig. 3: AC page 8 {HE 2 E} Fig. 53: HE page 58 {HF 2 E} Fig. 54: HF page 59 {HG 3 E} Fig. 55: HG page 60	SP0C-PW	{ID 0 C} Fig. 59: ID page 64
SP0B1	{HB 2 D} Fig. 50: HB page 55	SP0D_1	{GI 3 C} Fig. 46: GI page 51
SP0B2	{HD 0 D} Fig. 52: HD page 57 {HE 1 C} Fig. 53: HE page 58	SP0D_2	{EB 3 C} Fig. 32: EB page 37
SP0B3	{HE 2 C} Fig. 53: HE page 58	SP0D-A_1	{BD 2 C} Fig. 8: BD page 13
SP0B3_1	{HD 2 D} Fig. 52: HD page 57	SP0D-A_2	{BD 3 B} Fig. 8: BD page 13
SP0B3_2	{HD 2 D} Fig. 52: HD page 57	SP0D-B	{BD 2 C} Fig. 8: BD page 13
SP0B3_3	{HF 2 D} Fig. 54: HF page 59	SP0F	{BC 2 D} Fig. 8: BD page 13
SP0B-PT	{DP 3 C} Fig. 30: DP page 35	SP0F-B	{CE 0 D} Fig. 19: CE page 24
SP0C	{BA 1 E} Fig. 5: BA page 10 {GA 1 E} Fig. 38: GA page 43 {AC 3 C} Fig. 3: AC page 8 {IC 0 E} Fig. 58: IC page 63 {GP 4 E} Fig. 47: GP page 52 {FD 3 E} Fig. 36: FD page 41 {IF 3 E} Fig. 61: IF page 66 {GG 1 E} Fig. 44: GG page 49 {GH 0 E} Fig. 45: GH page 50 {FC 0 E} Fig. 35: FC page 40 {ID 2 E} Fig. 59: ID page 64 {CF 0 D} Fig. 20: CF page 25	SP0GS	{GI 0 D} Fig. 46: GI page 51
SP0C_1	{IF 2 D} Fig. 61: IF page 66	SPOH	{GD 3 C} Fig. 41: GD page 46
SP0C_3	{HD 3 D} Fig. 52: HD page 57	SPOH_1	{GD 0 C} Fig. 41: GD page 46
SP0C_4	{FE 2 D} Fig. 37: FE page 42	SPOH_2	{GD 1 C} Fig. 41: GD page 46
SP0C_6	{BC 2 D} Fig. 7: BC page 12	SPOH-C	{GI 1 E} Fig. 46: GI page 51
SP0C_9	{IC 2 E} Fig. 58: IC page 63	SPOHS	{GD 3 C} Fig. 41: GD page 46
SP0C1	{HE 3 C} Fig. 53: HE page 58	SP0L	{HE 1 D} Fig. 53: HE page 58
SP0C-24	{GA 1 E} Fig. 38: GA page 43 {AC 3 B} Fig. 3: AC page 8 {IC 4 E} Fig. 58: IC page 63 {BG 0 E} Fig. 11: BG page 16 {IF 0 E} Fig. 61: IF page 66 {KA 3 D} Fig. 66: KA page 71 {KB 4 E} Fig. 67: KB page 72 {KC 4 D} Fig. 68: KC page 73 {ID 0 E} Fig. 59: ID page 64	SP0L-B	{GG 2 D} Fig. 45: GH page 50 {GH 1 C} Fig. 45: GH page 50 {GH 3 C} Fig. 45: GH page 50
		SP0M	{GE 2 C} Fig. 42: GE page 47
		SP0M_1	{AC 3 B} Fig. 3: AC page 8 {GG 2 D} Fig. 45: GH page 50 {IF 2 E} Fig. 61: IF page 66 {KC 3 D} Fig. 68: KC page 73 {IA 0 E} Fig. 56: IA page 61
		SP0M_2	{GC 3 D} Fig. 40: GC page 45
		SP0M_3	{GE 0 C} Fig. 42: GE page 47
		SP0M_4	{GC 0 D} Fig. 40: GC page 45

SP0M-D	{GF 1 B} Fig. 43: GF page 48	SP137-A	{GG 2 C} Fig. 44: GG page 49 {GH 3 B} Fig. 45: GH page 50 {GH 1 B} Fig. 45: GH page 50
SP0M-D_1	{GF 3 C} Fig. 43: GF page 48	SP141A	{GB 0 B} Fig. 39: GB page 44
SP0MD_2	{GF 3 B} Fig. 43: GF page 48	SP141A-5	{HB 0 B} Fig. 50: HB page 55
SP0M-E	{GF 0 B} Fig. 43: GF page 48	SP141A-MD	{ID 2 B} Fig. 59: ID page 64
SP0P1	{HA 1 C} Fig. 49: HA page 54	SP141A-PT	{DP 3 B} Fig. 30: DP page 35
SP0R	{FA 3 C} Fig. 33: FA page 38	SP141B	{IF 1 C} Fig. 61: IF page 66
SP0R_1	{FA 0 D} Fig. 33: FA page 38	SP150	{HA 0 B} Fig. 49: HA page 54
SP0R_2	{FA 1 C} Fig. 33: FA page 38	SP163	{HB 2 C} Fig. 50: HB page 55
SPOR_FC	{FB 2 E} Fig. 33: FA page 38 {FB 1 D} Fig. 33: FA page 38	SP163_1	{HG 2 C} Fig. 55: HG page 60
SP0R1	{DP 2 D} Fig. 30: DP page 35	SP17B_1	{CC 2 C} Fig. 18: CC page 23
SP0R-G	{GF 0 C} Fig. 43: GF page 48 {FD 2 E} Fig. 36: FD page 41 {FA 0 D} Fig. 33: FA page 38 {FB 1 E} Fig. 34: FB page 39 {FC 1 E} Fig. 35: FC page 40	SP17B_2	{CI 1 E} Fig. 22: CI page 27
SP0T	{BF 1 D} Fig. 10: BF page 15	SP17F	{DG 0 D} Fig. 29: DG page 34
SP0TS	{HA 3 C} Fig. 49: HA page 54	SP18E	{DB 3 A} Fig. 24: DB page 29
SP0X_1	{CC 2 E} Fig. 18: CC page 23	SP18V	{BA 0 B} Fig. 5: BA page 10
SP0X_2	{BI 1 B} Fig. 13: BI page 18	SP196AA	{AA 1 D} Fig. 1: AA page 6
SP0X_3	{CI 4 D} Fig. 22: CI page 27	SP196AB	{AB 1 D} Fig. 2: AB page 7
SP0X—C	{EB 2 B} Fig. 32: EB page 37	SP196DR_1	{DB 2 A} Fig. 24: DB page 29
SP0XD	{IE 3 B} Fig. 60: IE page 65	SP196L	{GA 1 B} Fig. 38: GA page 43
SP0XE	{AC 0 D} Fig. 3: AC page 8 {CB 0 E} Fig. 17: CB page 22	SP196X	{FE 1 B} Fig. 37: FE page 42
SP0X-ES	{EB 3 C} Fig. 32: EB page 37	SP196X-B	{FE 1 C} Fig. 37: FE page 42
SP0XL	{GA 0 D} Fig. 38: GA page 43 {AC 0 B} Fig. 3: AC page 8 {JC 4 E} Fig. 65: JC page 70 {GG 0 E} Fig. 44: GG page 49 {GB 1 E} Fig. 39: GB page 44	SP1A	{AB 3 A} Fig. 2: AB page 7
SP0Y	{DG 0 D} Fig. 29: DG page 34	SP1B	{AA 1 A} Fig. 1: AA page 6
SP112C	{MA 1 C} Fig. 69: MA page 74	SP1E	{AA 1 D} Fig. 1: AA page 6
SP113C	{MA 1 C} Fig. 69: MA page 74	SP284	{AD 1 B} Fig. 4: AD page 9
SP115	{GF 0 B} Fig. 43: GF page 48	SP284-A	{BB 0 B} Fig. 6: BB page 11
SP115_1	{GF 2 B} Fig. 43: GF page 48	SP284D	{DB 0 A} Fig. 24: DB page 29
SP116	{GF 1 B} Fig. 43: GF page 48	SP32SP-L	{GI 1 C} Fig. 46: GI page 51
SP116_1	{GF 3 B} Fig. 43: GF page 48	SP336	{IB 1 C} Fig. 57: IB page 62
SP116A	{DE 2 D} Fig. 27: DE page 32	SP33SP	{GI 0 C} Fig. 46: GI page 51
SP131	{HE 3 B} Fig. 53: HE page 58	SP35	{GE 1 B} Fig. 42: GE page 47
SP131_1	{IA 0 D} Fig. 56: IA page 61	SP35_2	{GE 0 C} Fig. 42: GE page 47
SP131_2	{HD 3 D} Fig. 52: HD page 57	SP350R_PW	{ID 1 C} Fig. 59: ID page 64
SP132	{HD 2 C} Fig. 52: HD page 57	SP37	{GE 2 B} Fig. 42: GE page 47
SP135	{HD 3 B} Fig. 52: HD page 57	SP37_2	{GE 1 C} Fig. 42: GE page 47
		SP370	{IF 0 C} Fig. 61: IF page 66
		SP370A	{HE 0 C} Fig. 53: HE page 58
		SP384	{GP 0 C} Fig. 47: GP page 52
		SP385	{GP 0 D} Fig. 47: GP page 52
		SP387	{GP 1 C} Fig. 47: GP page 52
		SP400	{XA 0 D} Fig. 71: XA page 76

SP400_1	{XA 0 C} Fig. 71: XA page 76	SP407-J	{XA 3 B} Fig. 71: XA page 76
SP400_2	{BF 3 B} Fig. 10: BF page 15	SP407-K	{XA 3 C} Fig. 71: XA page 76
SP400_3	{BE 1 D} Fig. 9: BE page 14	SP407-L	{XA 3 D} Fig. 71: XA page 76
SP400_BB	{BI 3 B} Fig. 13: BI page 18	SP407-M	{XA 3 B} Fig. 71: XA page 76
SP400_SG	{BK 2 C} Fig. 15: BK page 20	SP407V	{JB 3 C} Fig. 64: JB page 69
SP400-B	{BH 1 D} Fig. 12: BH page 17	SP408	{JC 1 C} Fig. 65: JC page 70
SP400-ES	{EB 2 C} Fig. 32: EB page 37	SP409	{JC 1 B} Fig. 65: JC page 70
SP400-L	{XA 0 D} Fig. 71: XA page 76	SP410	{GA 3 D} Fig. 38: GA page 43
SP400V	{JB 3 C} Fig. 64: JB page 69	SP410_1	{GF 3 B} Fig. 43: GF page 48
SP401	{XA 1 D} Fig. 71: XA page 76	SP410-AB	{BG 1 C} Fig. 11: BG page 16
SP401_1	{XA 1 C} Fig. 71: XA page 76	SP426	{BD 2 C} Fig. 8: BD page 13
SP401_2	{BF 3 C} Fig. 10: BF page 15	SP472	{FB 1 B} Fig. 34: FB page 39
SP401_3	{BE 1 D} Fig. 9: BE page 14	SP490	{KC 0 B} Fig. 68: KC page 73
SP401_BB	{BI 3 B} Fig. 13: BI page 18	SP490_1	{KC 0 C} Fig. 68: KC page 73
SP401_SG	{BK 2 C} Fig. 15: BK page 20	SP491	{IF 3 B} Fig. 61: IF page 66
SP401-B	{BH 1 D} Fig. 12: BH page 17	SP498LR-	{KC 2 B} Fig. 68: KC page 73
SP401-ES	{EB 2 C} Fig. 32: EB page 37	SP498LR+	{KC 2 B} Fig. 68: KC page 73
SP401-L	{XA 1 D} Fig. 71: XA page 76	SP498RR-	{KC 3 B} Fig. 68: KC page 73
SP401V	{JB 3 C} Fig. 64: JB page 69	SP498RR+	{KC 3 B} Fig. 68: KC page 73
SP406	{XA 3 D} Fig. 71: XA page 76	SP499LF-	{KA 2 D} Fig. 66: KA page 71 {KB 3 D} Fig. 67: KB page 72 {KC 1 D} Fig. 68: KC page 73
SP406_1	{XA 3 C} Fig. 71: XA page 76	SP499LF-_1	{KB 4 C} Fig. 67: KB page 72
SP406_2	{CC 0 C} Fig. 18: CC page 23	SP499LF+	{KA 2 D} Fig. 66: KA page 71 {KB 3 D} Fig. 67: KB page 72 {KC 1 D} Fig. 68: KC page 73
SP406_A	{CI 2 C} Fig. 22: CI page 27	SP499LF+_1	{KB 3 C} Fig. 67: KB page 72
SP406_BB	{BI 2 B} Fig. 13: BI page 18	SP499RF-	{KA 2 D} Fig. 66: KA page 71 {KB 3 D} Fig. 67: KB page 72 {KC 1 D} Fig. 68: KC page 73
SP406-A	{XA 3 A} Fig. 71: XA page 76	SP499RF-_1	{KB 2 C} Fig. 67: KB page 72
SP406-ES	{EB 0 B} Fig. 32: EB page 37	SP499RF+	{KA 1 D} Fig. 66: KA page 71 {KB 2 D} Fig. 67: KB page 72 {KC 2 D} Fig. 68: KC page 73
SP406-F_1	{XA 2 D} Fig. 71: XA page 76	SP499RF+_1	{KB 2 C} Fig. 67: KB page 72
SP406-J	{XA 3 B} Fig. 71: XA page 76	SP501	{IA 1 B} Fig. 56: IA page 61
SP406-K	{XA 3 C} Fig. 71: XA page 76	SP504L	{IA 3 B} Fig. 56: IA page 61 {IA 3 D} Fig. 56: IA page 61
SP406-L	{XA 3 D} Fig. 71: XA page 76	SP504R	{IA 3 D} Fig. 56: IA page 61
SP406-M	{XA 3 B} Fig. 71: XA page 76	SP505	{IA 1 C} Fig. 56: IA page 61
SP406V	{JB 3 C} Fig. 64: JB page 69	SP52_1	{GC 2 C} Fig. 40: GC page 45
SP407	{XA 3 D} Fig. 71: XA page 76	SP52_2	{GC 3 C} Fig. 40: GC page 45
SP407_1	{XA 3 C} Fig. 71: XA page 76	SP52_3	{GC 0 C} Fig. 40: GC page 45
SP407_2	{CC 0 C} Fig. 18: CC page 23	SP552	{BB 4 B} Fig. 6: BB page 11
SP407_A	{CI 2 C} Fig. 22: CI page 27		
SP407_BB	{BI 2 B} Fig. 13: BI page 18		
SP407-A	{XA 3 A} Fig. 71: XA page 76		
SP407-ES	{EB 0 B} Fig. 32: EB page 37		
SP407-F_1	{XA 4 D} Fig. 71: XA page 76		

SP554	{BB 4 B} Fig. 6: BB page 11	SP90	{GF 0 B} Fig. 43: GF page 48
SP558	{BB 3 B} Fig. 6: BB page 11	SP90_1	{GF 2 C} Fig. 43: GF page 48
SP559L	{CC 0 D} Fig. 18: CC page 23 {CI 0 D} Fig. 22: CI page 27	SP90_FC	{GF 2 D} Fig. 43: GF page 48
SP56	{GD 0 B} Fig. 41: GD page 46	SP90_HL	{GD 2 B} Fig. 41: GD page 46
SP56_HL	{GD 3 B} Fig. 41: GD page 46	SP90A-A	{BH 2 C} Fig. 12: BH page 17
SP562A	{BA 2 B} Fig. 5: BA page 10	SP90-C	{GF 0 B} Fig. 43: GF page 48
SP563A	{BA 2 C} Fig. 5: BA page 10	SP952	{FA 3 C} Fig. 33: FA page 38
SP564A	{BA 1 C} Fig. 5: BA page 10	SP952_1	{FA 0 B} Fig. 33: FA page 38
SP56F	{GA 2 D} Fig. 38: GA page 43	SP952_2	{FA 1 C} Fig. 33: FA page 38
SP56F_1	{GD 0 B} Fig. 41: GD page 46	SP953	{CE 0 C} Fig. 19: CE page 24
SP56F_2	{GD 2 C} Fig. 41: GD page 46	SP962	{BA 4 C} Fig. 5: BA page 10
SP573	{DP 1 C} Fig. 30: DP page 35	SP962-D	{BA 3 C} Fig. 5: BA page 10
SP59	{GI 3 C} Fig. 46: GI page 51	SPA124	{DE 1 C} Fig. 27: DE page 32
SP592B	{CB 1 C} Fig. 17: CB page 22	SPA135A	{DE 1 D} Fig. 27: DE page 32
SP597	{BA 2 C} Fig. 5: BA page 10	SPA140A	{DE 2 D} Fig. 27: DE page 32
SP6204	{EB 1 D} Fig. 32: EB page 37	SPA143	{DF 0 A} Fig. 28: DF page 33
SP6207	{EB 1 C} Fig. 32: EB page 37	SPA146	{DF 3 B} Fig. 28: DF page 33
SP639	{DP 1 C} Fig. 30: DP page 35	SPA149A	{DE 2 D} Fig. 27: DE page 32
SP639_FC	{DP 0 C} Fig. 30: DP page 35	SPA161	{DF 2 C} Fig. 28: DF page 33
SP639A	{DP 2 B} Fig. 30: DP page 35	SPABS	{EA 4 C} Fig. 31: EA page 36
SP639-B	{DP 3 B} Fig. 30: DP page 35	SPANODE	{AD 2 C} Fig. 4: AD page 9
SP700	{IC 2 D} Fig. 58: IC page 63	SPANODE"X"	{AD 1 C} Fig. 4: AD page 9
SP700_MD	{IC 2 D} Fig. 59: ID page 64	SPAUX-0	{NA 3 D} Fig. 70: NA page 75 {NA 2 D} Fig. 70: NA page 75 {NA 1 D} Fig. 70: NA page 75
SP710	{IE 1 B} Fig. 60: IE page 65	SPCATHODE	{AD 2 B} Fig. 4: AD page 9
SP75	{GB 1 B} Fig. 39: GB page 44	SPCATHODE"Y"	{AD 1 B} Fig. 4: AD page 9
SP774	{EA 2 B} Fig. 31: EA page 36	Splice242_4	{HG 1 D} Fig. 55: HG page 60
SP817_1	{DB 2 D} Fig. 24: DB page 29	Splice260_27	{GF 1 B} Fig. 43: GF page 48
SP817_2	{DB 2 C} Fig. 24: DB page 29	SPNEU	{DF 0 C} Fig. 28: DF page 33
SP817_3	{DB 2 C} Fig. 24: DB page 29	SPOM-A	{AC 3 D} Fig. 3: AC page 8
SP817_4	{DB 3 C} Fig. 24: DB page 29	SPOXL	{BA 4 D} Fig. 5: BA page 10
SP817_5	{DB 3 C} Fig. 24: DB page 29	SPV0C	{JB 1 C} Fig. 64: JB page 69
SP817_6	{DB 3 D} Fig. 24: DB page 29	SPV196C	{JB 1 C} Fig. 64: JB page 69
SP818	{DG 1 B} Fig. 29: DG page 44		

Glossary

ABS	Antilock brake system	L5	Long high cab, VN780
ATC	Automatic temperature control	LECM	Living Environment Control Module (Sleeper Control Panel)
AUXSW-6	Wiring for six auxiliary switches for body building	LF	Left front
AWD	All wheel drive	LHD	Left hand drive
BBM	Body builder module	LH	Left hand side
BBOX	Battery box	LR	Left rear
CLU	Central locking unit	MECHTRAN	Mechanical transmission
CU-BAS	Basic version with stepper motor without air condition	MUF-HOR	Horizontal muffler
CU-ECC	Electronic controlled climate control air condition	PH-CAB	Cab parking heater
CU-HEAT	Heater unit	PTO	Power take off
CU-MCC	Manual controlled climate control air condition	RCU	Remote control unit
EBR-EPG	EPG (Exhaust Pressure Governor)	RF	Right front
EBR-EXH	Exhaust Brake	RHD	Right hand drive
EBR-VEB	Volvo Engine Brake	RH	Right hand side
ELCE-CK	Electrical complete kit for body builder	RR	Right rear
ENG-VE12	Volvo engine 12 liter	SRS	Supplementary restraint system
HL-BASIC	Basic headlamps	STWPOS-L	Steering wheel position left hand side
LCM	Light control module	STWPOS-R	Steering wheel position right hand side
L1H1	Day cab	SWM	Steering wheel module
L3H1	Medium cab, VN430	TL	Tail lamps
L4H2	Long high cab, VN630	VECU	Vehicle electronic control unit
L4H4	Long high cab, VN670	VL or VAL	Volvo Link Satellite Communication System

Wire Color Codes

BL	Blue
BN	Brown
GN	Green
GR	Grey
OR	Orange
P	Pink
R	Red
SB	Black
VO	Violet
W	White
Y	Yellow

Note: If a wire has two colors, it is written like the following example: Y/R = Yellow/Red.

VOLVO

Volvo Trucks North America, Inc.

P.O. Box 26115, Greensboro, NC 27402-6115

Volvo Trucks Canada, Ltd.

5600A Cancross Court, Mississauga, Ontario L5R 3E9

<http://www.volvotrucks.volvo.com>