

Road Choice™

MP3 CD Player/Receiver

English

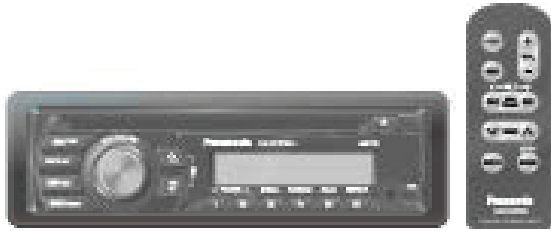



Model: **83176265**
Operating Instructions





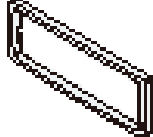
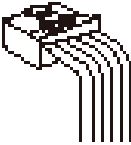

MP3

- ⌋ Please read these instructions carefully before using this product and keep this manual for future reference.

Accessories

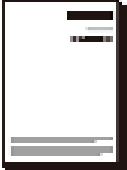
			
Mounting Collar	Trim Plate	Power Connector	Remote Control Unit (a battery included)
Q'ty: 1	Q'ty: 1	Q'ty: 1	Q'ty: 1
(FX0214C384ZB)	(YFC054C079YA)	(YAJ024C146CA)	(YFX994C199CA)

				
Lock Cancel Plate	Mounting Bolt (5 mm ø)	Rubber Bushing	Operating Instructions	Installation Instructions
Installation kit			Instruction kit	
Q'ty: 1 set			Q'ty: 3	Q'ty: 1
(ZZBISCP137U)			(English: YFM264C321CA) (Français: YFM264C322CA) (Español: YFM264C323CA)	(YFM294C211CA)

Notes:

- ⌋ The number in parentheses underneath each accessory part name is the part number for maintenance and service.
- ⌋ Accessories and their part numbers are subject to modification without prior notice due to improvements.
- ⌋ Mounting Collar and Trim Plate are mounted on the main unit at shipment.

Safety Information

Read the operating instructions for the unit and all other components of your car audio system carefully before using the system. They contain instructions about how to use the system in a safe and effective manner. Panasonic assumes no responsibility for any problems resulting from failure to observe the instructions given in this manual.

This manual uses pictographs to show you how to use the product safely and to alert you to potential dangers resulting from improper connections and operations. The meanings of the pictographs are explained below. It is important that you fully understand the meanings of the pictographs in order to use this manual and the system properly.



Warning

This pictograph intends to alert you to the presence of important operating instructions and installation instructions. Failure to heed the instructions may result in severe injury or death.



Caution

This pictograph intends to alert you to the presence of important operating instructions and installation instructions. Failure to heed the instructions may result in injury or material damage.



Warning

Observe the following warnings when using this unit.

- The driver should neither watch the display nor operate the system while driving.
- Watching the display or operating the system will distract the driver from looking ahead of the vehicle and can cause accidents. Always stop the vehicle in a safe location and use the parking brake before watching the display or operating the system.
- Use the proper power supply.
- This product is designed for operation with a negative grounded 12 V DC battery system. Never operate this product with other battery systems, especially a 24 V DC battery system.
- Keep batteries and insulation film out of reach of infants. Batteries and insulation film can be ingested, so keep them out of the reach of infants. If an infant ingests a battery or insulation film, please seek immediate medical attention.
- Protect the Deck Mechanism.
- Do not insert any foreign objects into the slot of this unit.
- Do not disassemble or modify the unit.
- Do not disassemble, modify the unit or attempt to repair the product yourself. If the product needs to be repaired, consult your dealer or an authorized Panasonic Service Center.
- Do not use the unit when it is out of order.
- If the unit is out of order (no power, no sound) or in an abnormal state (has foreign objects in it, is exposed to water, smoking, or smells), turn it off immediately and consult your dealer or an authorized Panasonic Service Center.
- The remote control unit should not lie about in the car. If the remote control unit lies about, it could fall on the floor while driving, get wedged under the brake pedal, and lead to a traffic accident.
- Refer fuse replacement to qualified service personnel.
- When the fuse blows out, eliminate the cause and have it replaced with the fuse prescribed for this unit by a qualified service engineer. Incorrect replacement of the fuse may lead to smoke, fire, and damage to the product.

Observe the following warnings when installing.

- Disconnect the lead from the negative (-) battery terminal before installation.
- Wiring and installation with the negative (-) battery terminal connected may cause electrical shock and injury due to a short circuit. Some cars equipped with the electrical safety system have specific procedures of battery terminal disconnection. **FAILURE TO FOLLOW THE PROCEDURE MAY LEAD TO THE UNINTENDED ACTIVATION OF THE ELECTRICAL SAFETY SYSTEM RESULTING IN DAMAGE TO THE VEHICLE AND PERSONAL INJURY OR DEATH.**
- Never use safety-related components for installation, grounding, and other such functions.
- Do not use safety-related vehicle components (fuel tank, brake, suspension, steering wheel, pedals, airbag, etc.) for wiring or fixing the product or its accessories.
- Installing the product on the air bag cover or in a location where it interferes with airbag operation is prohibited.
- Check for piping, gasoline tank, electric wiring, and other items before installing the product.
- If you need to open a hole in the vehicle chassis to attach or wire the product, first check where the wire harness, gasoline tank, and electric wiring are located. Then open the hole from outside if possible.
- Never install the product in a location where it interferes with your field of vision.
- Never have the power cord branched to supply other equipment with power.
- After installation and wiring, you should check the normal operation of other electrical equipment.
- The continuation of their using in abnormal conditions may cause fire, electrical shock or a traffic accident.
- In the case of installation to an airbag-equipping car, confirm warnings and cautions of the vehicle manufacturer before installation.
- Make sure the leads do not interfere with driving or getting in and out of the vehicle.
- Insulate all exposed wires to prevent short circuiting.
- Keep accessories out of reach of infants.
- Accessories can be ingested, so keep them out of the reach of infants. If an infant ingests accessories, please seek immediate medical attention.



Caution

Observe the following cautions when using this unit.

- Keep the sound volume at an appropriate level.
- Keep the volume level low enough to be aware of road and traffic conditions while driving.
- This unit is designed for use exclusively in automobiles.
- Do not operate the unit for a prolonged period with the engine turned off.
- Operating the audio system for a long period of time with the engine turned off will drain the battery
- Do not expose the unit to direct sunlight or excessive heat. Otherwise these will raise the interior temperature of the unit, and it may lead to smoke, fire, or other damage to the unit.
- Do not use the product where it is exposed to water, moisture, or dust.
- Exposure of the unit to water, moisture, or dust may lead to smoke, fire, or other damage to the unit. Make especially sure that the unit does not get wet in car washes or on rainy days.
- Set the volume level to low enough before the AUX connection is completed.
- Failure to observe this, the loud noise may come out and damage your speakers and your hearing. Direct connection of the speaker/headphone output of an external device without any attenuator may distort sound or damage the connected external device.

Observe the following cautions when installing.

- Refer wiring and installation to qualified service personnel.
- Installation of this unit requires special skills and experience. For maximum safety, have it installed by your dealer. Panasonic is not liable for any problems resulting from your own installation of the unit.
- Follow the instructions to install and wire the product.
- Not following the instructions to properly install and wire the product could cause an accident or fire.
- Take care not to damage the leads.
- When wiring, take care not to damage the leads. Prevent them from getting caught in the vehicle chassis, screws, and moving parts such as seat rails. Do not scratch, pull, bend or twist the leads. Do not run them near heat sources or place heavy objects on them. If leads must be run over sharp metal edges, protect the leads by winding them with vinyl tape or similar protection.

- Use the designated parts and tools for installation.
- Use the supplied or designated parts and appropriate tools to install the product. The use of parts other than those supplied or designated may result in internal damage to the unit. Faulty installation may lead to an accident, a malfunction or fire.
- Do not block the air vent or the cooling plate of the unit. Blocking these parts will cause the interior of the unit to overheat and will result in fire or other damage.
- Do not install the product where it is exposed to strong vibrations or is unstable.
- Avoid slanted or strongly curved surfaces for installation. If the installation is not stable, the unit may fall down while driving and this can lead to an accident or injury.
- Installation Angle**
- The product should be installed in a horizontal position with the front end up at a convenient angle, but not more than 30°.
- The user should bear in mind that in some areas there may be restrictions on how and where this unit must be installed. Consult your dealer for further details.
- Wear gloves for safety. Make sure that wiring is completed before installation.
- To prevent damage to the unit, do not connect the power connector until the whole wiring is completed.
- Do not connect more than one speaker to one set of speaker leads. (except for connecting to a tweeter)

Observe the following cautions when handling the battery for the remote control unit.

- Use only specified battery (CR2025).
- Match the polarity of the battery with the (+) and (-) marks in the battery case.
- Replace a dead battery as soon as possible.
- Remove the battery from the remote control unit when not using it for an extended period of time.
- Insulate the battery (by placing them in a plastic bag or covering them with vinyl tape) before disposal or storage.
- Dispose of the battery according to the local regulations.
- Do not disassemble, recharge, heat or short the battery. Do not throw a battery into a fire or water.
- In case of battery leakage**
- Thoroughly wipe the battery liquid off the battery case and insert new battery.
- If any part of your body or clothing comes into contact with battery liquid, wash it with plenty of water.
- If battery liquid comes into contact with your eyes, wash them with plenty of water and get immediate medical attention.



Caution

THIS PRODUCT IS A CLASS I LASER PRODUCT.
USE OF CONTROLS OR ADJUSTMENTS OR PERFORMANCE OF PROCEDURES OTHER THAN THOSE SPECIFIED HEREIN MAY RESULT IN HAZARDOUS RADIATION EXPOSURE.
DO NOT OPEN COVERS AND DO NOT REPAIR BY YOURSELF. REFER SERVICING TO QUALIFIED PERSONNEL.

The following applies only in the U.S.A.

Part 15 of the FCC Rules

FCC Warning:

Any unauthorized changes or modifications to this equipment would void the user's authority to operate this device.

Before Reading These Instructions

Panasonic welcomes you to our constantly growing family of electronic products owners.

We endeavor to give you the advantages of precise electronic and mechanical engineering, manufactured with carefully selected components, and assembled by people who are proud of the reputation their work has built for our company. We know this product will bring you many hours of enjoyment, and after you discover the quality, value and reliability we have built into it, you too will be proud to be a member of our family.

Pana Pacific Limited Warranty Agreement

Pana Pacific warrants vehicle audio products it distributes in the United States, to be free from defects in material and workmanship, in accordance with the following.

For twelve months after delivery, we will repair or at our option replace at no charge any audio product which, under normal conditions of use and service proves to be defective in materials or workmanship. However, this warranty does not cover expenses incurred in the removal or reinstallation of any audio product, whether or not proven defective. This warranty is limited to the original consumer purchaser and is not transferable. Repaired and replaced products shall assume the identity of the original for the purpose of this warranty and this warranty shall not be extended with respect to such products.

To obtain performance of this warranty, contact Pana Pacific warranty return center by phone at 1-800-848-6560. A dated purchase receipt or other proof that the product is within the warranty period will be required in order to honor the claim.

Specifically excluded from this warranty are failures caused by, misuse, neglect, abuse, improper operation or installation, dropping or damaging a faceplate, unauthorized service or parts, or failure to follow normal maintenance activities. Also excluded from this warranty are the correction of improper installation and the elimination of external electromagnetic interference including but not limited to satellite radio FM modulation performance.

This warranty sets forth the exclusive remedies with respect to the products covered by it. We shall not be held liable for any incidental, consequential, special, or punitive damages arising from the sale, use, or distribution of any audio products. No attempt to alter, modify, or amend this warranty shall be effective unless authorized in writing by an officer of Pana Pacific Inc.

This warranty gives you specific legal rights, and you may also have other rights which vary from state to state in the United States of America. In the event any provision, or any part or portions of this warranty shall be found invalid, void or otherwise unenforceable, such holding shall not affect the remaining part or portion of that provision or any other provision hereof.

Notes on Discs

How to hold the disc

- i Do not touch the underside of the disc.
- i Do not scratch the disc.
- i Do not bend disc.
- i When not in use, keep disc in the case.

Prohibited style



Unusable discs

Do not use discs that fit any of the descriptions given below. Using these discs may damage the discs or cause the unit to malfunction.

- i Special discs in a shape which is not round

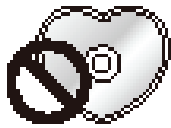

- i Partly or wholly transparent disc



Wholly transparent disc*

Partly transparent disc

*Wholly semi-transparent disc may not be played back.

- i Discs with adhered labels, etc. on them

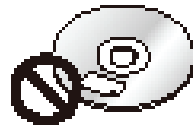

Disc with adhered stickers or tape

Labels created by a printer or tape

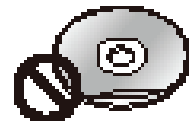

Protective films or sheets

Disc accessories (stabilizers, etc.)

- i Damaged or deformed discs

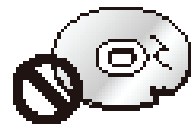
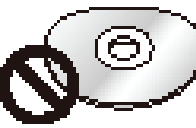

Shoddily made discs

Discs with cracks, scratches or parts missing

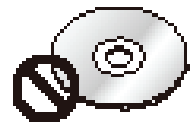

Discs with burrs

Please remove the burrs before use.

Disc insert

The surfaces of new discs tend to be slippery. Therefore, when using such a disc for the first time, it may not load satisfactorily even when it has been inserted into the unit. At a time like this, insert the disc into the unit as far as it will go until it is loaded properly.

- i When inserting a disc into or ejecting and removing it from the unit, insert it straight in or eject and remove it straight out in parallel with the unit. Otherwise, the disc may be scratched or marked in the process.
- i When inserting a disc, do not put one disc on another. Failure to observe this may cause the discs to be jammed.

Do not leave discs in the following places:

- i Direct sunlight
- i Near heaters
- i Dirty, dusty and damp areas
- i On seats and dashboards

Disc cleaning

Use a dry, soft cloth to wipe from the center outward.

Do not attach any seals or labels to your discs.

Do not write on the disc label in a heavy pen or ballpoint pen.



<Correct>



<Wrong>

Notes on CD-Rs/RWs

- i You may have trouble playing back some CD-R/RW discs recorded on CD recorders (CD-R/RW drives), either due to their recording characteristics or dirt, fingerprints, scratches, etc. on the disc surface.
- i CD-R/RW discs are less resistant to high temperatures and high humidity than ordinary music CDs. Leaving them inside a vehicle for extended periods may damage and make playback impossible.
- i The unit may not successfully playback a CD-R/RW that was made by the combination of writing software, a CD recorder (CD-R/RW drives) and a disc if they are incompatible with one another.
- i This player does not play CD-R/RW discs if the session is not closed.
- i Be sure to observe the handling instructions of CD-R/RW discs.
- i This player does not play CD-R/RW discs which contain other than CD-DA or MP3 data.

Remote Control Unit

Notes

- i This instruction manual explains operations for use with the buttons on the main unit. (Different operations excluded)
- i When using the remote control unit, aim the remote control unit at the remote sensor and operate it.

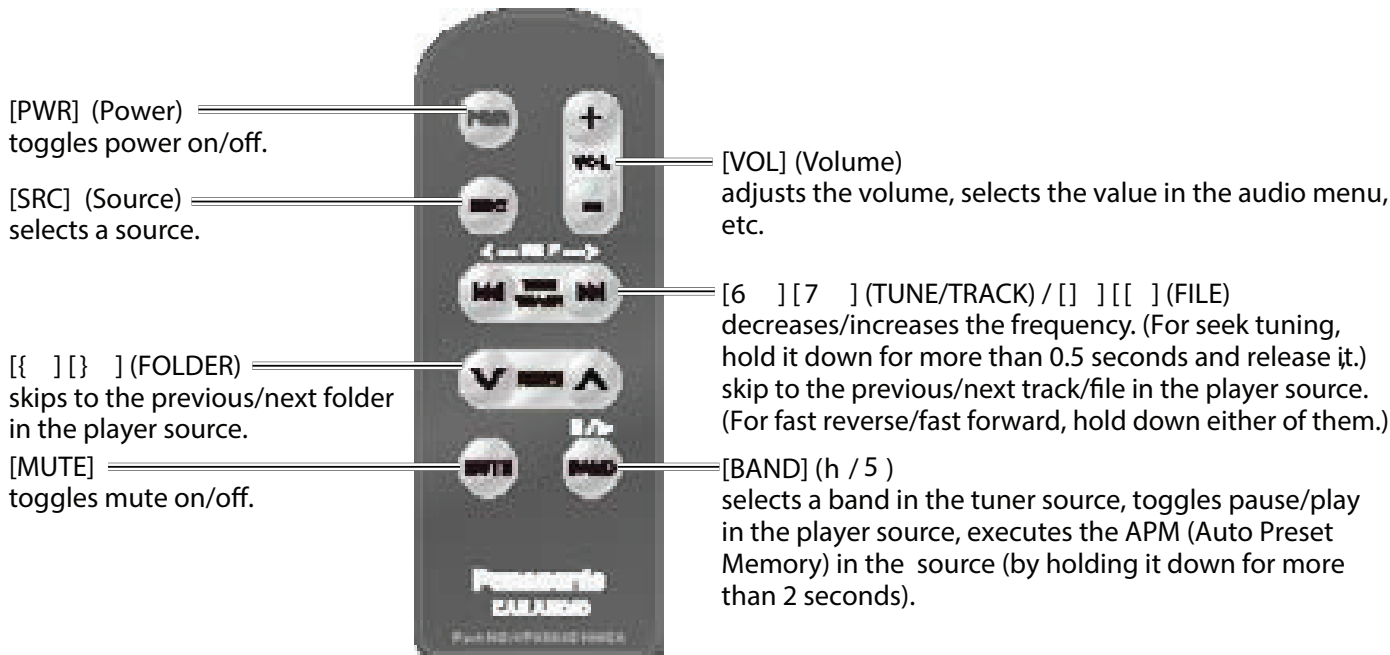

Battery replacement

- 1 Remove the battery holder from the remote control unit placed on a flat surface.
 - q Stick your thumbnail into the groove, and push the holder in the direction of the arrow.
 - w Pull it out in the direction of the arrow using your thumbnail and another finger.

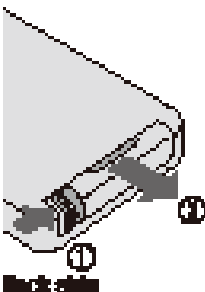

- 2 Insert a battery in the case with (+) side facing up.
- 3 Put the case back.

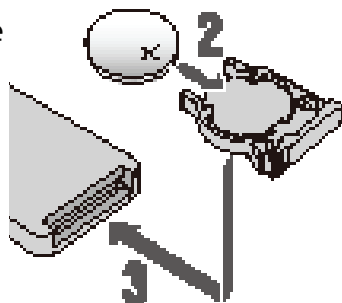

Notice

This product contains a CR Coin Cell Lithium Battery which contains Perchlorate Material - special handling may apply.

See www.dier.ca/poethazardawareness/perchlorate



Warning

Keep batteries and insulation film out of reach of infants.

Batteries and insulation film can be ingested, so keep them out of the reach of infants. If an infant ingests a battery or insulation film, please seek immediate medical attention.



Caution

- i Remove and dispose of the discharged battery immediately.
- i Do not disassemble, heat or short a battery. Do not throw a battery into a fire or water.
- i Follow local regulations when disposing of a battery.
- i Improper use of batteries may cause overheating, an explosion or ignition, resulting in injury or a fire.

Note Battery Information:

Battery Type: Lithium battery (CR2025) (Included in the remote control unit)

Battery Life: Approximately 6 months under normal use (at room temperature)

Preparation

First Time Power On

- 1 Set your car's ignition switch to the ACC or ON position.
- 2 Press [SRC] (PWR : Power).



Battery Installation

Pull the insulation film out from the backside of the remote control unit gently.

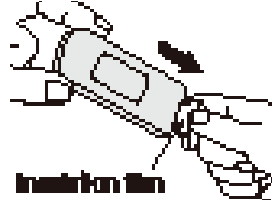

Note Battery Information:

Battery Type: Lithium battery (CR2025) (Included in the remote control unit)

Battery Life: Approximately 6 months under normal use (at room temperature)

Clock Setting

The 12-hour (AM/PM) system is used for the clock display.

- 1 Press [CLK] (Clock).

CLK ADJUST (clock display)

- 2 Hold down [CLK] for more than 2 seconds.

FM 1 12:00 AM Hour blinks.

- 3 Adjust the hour.

FM 1 1:00 AM Hour entered

[7]: sets the hour ahead.

[6]: sets the hour back.

- 4 Press [CLK].

FM 1 1:00 AM Minute blinks.

- 5 Adjust the minute.

FM 1 1:15 AM Minute entered

[7]: sets the minute ahead.

[6]: sets the minute back.

- 6 Press [CLK].

FM 1 1:15 AM Completed

Notes

- "CLK ADJUST" is displayed before adjusting the clock.
- Hold down [6] or [7] to change numbers rapidly.
- When "NO DISC" is displayed, the clock cannot be adjusted.
- When you want to readjust the clock, repeat steps 2 to 6

Clock Display at Power Off

Press [DISP] to change the display.

cd Display off

cd
8:15 AM Clock display (Default)

General

Caution

Set the volume level to low enough before the AUX connection is completed.
Failure to observe this may generate loud noise and accordingly damage your speakers and your hearing.

[SRC] (Source)
selects a source.
[PWR] (Power)
toggles power on/off.

[MUTE]
toggles mute on/off.
[SQ] (Sound Quality)
selects a sound type
(SQ).



AUX Connector(3.5 mm ø stereo)
From line output of external sound/audio device
(ex. Silicon audio player, HDD player, etc.)

Remote Control Sensor

[VOL] (Volume)

Power On/Off

Set your car's ignition switch to the ACC or ON position.
Power on: Press [SRC] (PWR) .

WELCOME

Power off: Hold down [SRC] (PWR) for more than 1 second.

Source Selection

Press [SRC] to change the source.

RADIO

Radio

d

CD

Disc player

d

AUX

AUX

When a device connected to the front AUX terminal of this unit

d

(Return to "RADIO")

Volume Adjustment

(Setting Range: 0 to 40, Default: 18)

Turn [VOL] clockwise to increase the volume, and counterclockwise to decrease the volume.

VOL 18

Volume level (0 to 40) (default: 18)

Mute

Press [MUTE] to mute the sound completely.

MUTE

Press again to cancel.

SQ (Sound Quality)

SQ is a function that can call up various sound types at the touch of button in accordance with your listening music type.

Hold down [SQ] for more than 2 seconds to select the sound type as follows:

SQ-FLAT

(FLAT)

Flat frequency response:

does not emphasize any part. (default)

d

SQ-ROCK

(ROCK)

Speedy and heavy sound:

exaggerates bass and treble.

d

SQ-POP

(POP)

Wide-ranged and deep sound:

slightly emphasizes bass and treble.

d

SQ-VOCAL

(VOCAL)

Clear sound:

emphasizes middle tone and slightly emphasizes treble.

d

(Return to "FLAT")

Note Settings of SQ, bass and treble are influenced one another. If such an influence causes distortion to the audio signal, readjust bass/treble or volume.

Radio (AM/FM)



Caution

To ensure safety, never attempt to preset stations while you are driving.

[SRC] (Source) selects a source.

[BAND] selects a band in the radio source. (APM) (Auto Preset Memory) executes APM in the radio source (by holding it down for more than 2 seconds).

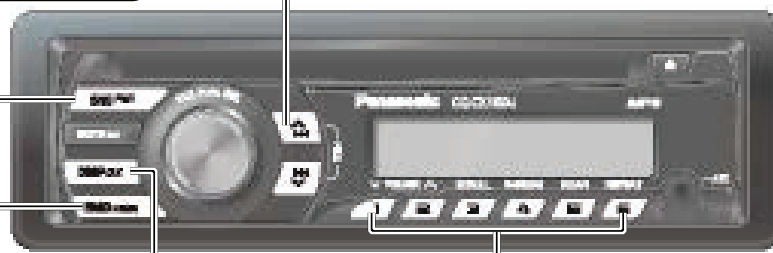

[DISP] (Display) switches the information on the display.

Preset buttons [1] through [6] select a preset station in the radio source, preset the current station (by holding it down for more than 2 seconds).

[6] [7]

decreases/increases the frequency. (For seek tuning, hold it down for more than 0.5 seconds and release it.)

Operation Flow

- 1 Press [SRC] to select the radio source.
- 2 Press [BAND] to select a band.



- 3 Select a station.

Frequency Adjustment

[6]: Lower

[7]: Higher

Note For station search, hold down either of the buttons for more than 0.5 seconds and release it.

Preset Station Selection

Press the corresponding preset button from [1] through [6] to tune in a preset station.

Radio Source Display

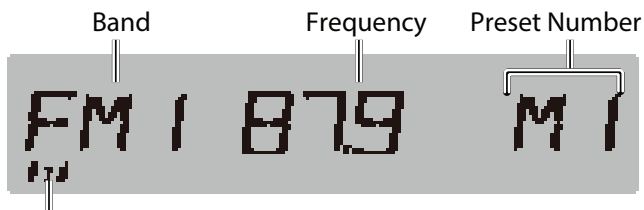

lights while receiving an FM stereo signal.

Display Change

Press [DISP] to change the display.

FM 1 87.9 Radio mode display (Default)
cd

FM 1 8:15 AM Clock display

Station Preset

Up to 6 stations can be preset in each of AM, FM1, FM2, and FM3.

Preset stations can be simply called up by pressing [1] through [6].

Auto Preset Memory (APM)

With this operation, stations with good receiving conditions can be automatically stored in the preset memory.

- 1 Select a band.
- 2 Hold down [BAND] (APM) for more than 2 seconds.

The preset stations under best receiving conditions are received for 5 seconds each after presetting the stations (SCAN). To stop scanning, press one of the buttons from [1] through [6].

Note New stations overwrite existing saved stations.

Manual Station Preset

- 1 Tune into a station.
- 2 Hold down one of the preset buttons from [1] through [6] for more than 2 seconds.

FM 1 (blinks once)

Note New stations overwrite existing saved stations.

Disc Player

Notes:

- ; The power will be turned on automatically when a disc is loaded.
- ; A disc which has both CD-DA data and MP3 data on it may not be reproduced normally.

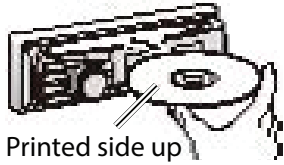

Printed side up

Disc slot

takes a disc in with the printed side facing up.

[{ }] (FOLDER)
skip to the previous/next folder.

[u] (Eject)
ejects the disc.

[SRC] (Source)
selects a source.

[DISP] (Display)
switches the information on the display.

[BAND] (h / 5) (Play/Pause)
toggles between pause and play with the player source.

[6] [7]

skip to the previous/next track/file in the player mode.
For fast reverse/fast forward, hold down either of them.

[4] (RANDOM)/[5] (SCAN) / [6] (REPEAT)
toggles on/off each play mode.

[3] (SCROLL)
scrolls the information on the display.

Notes:

- ; Do not insert a disc when the indicator lights.
- ; Refer to the sections of "Notes on Discs" and "Notes on MP3".
- ; This unit does not support 8 cm {3} discs.
- ; Do not insert foreign objects into the disc slot.

Operation Flow

- 1 Press [SRC] to select the Disc Player source.
- 2 Select a desired portion.

Track/File Selection

Press [6] / [7].

Note To perform fast forward/reverse, hold down either of them.

Disc Player (CD-DA disc):

Previous/next track

Disc Player (MP3 disc):

Previous/next file

Folder Selection (MP3)

[}] (FOLDER) : Next folder

[{] (FOLDER) : Preceding folder

Pause

Press [BAND] (h / 5).

Press again to cancel.

Player Source Display

CD-DA Mode Display

Lights when a disc is loaded.

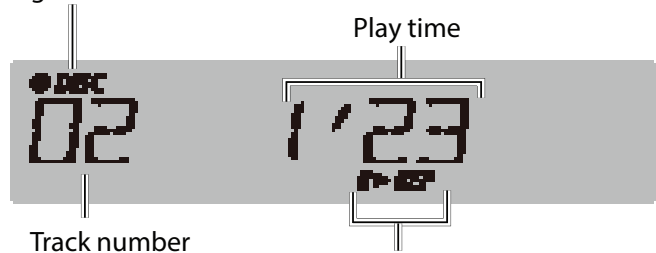

Track number

Play time

Play Mode indicators

Lights when each mode is activated.

Random play

Repeat play

MP3 Mode Display

Lights when a disc is loaded.

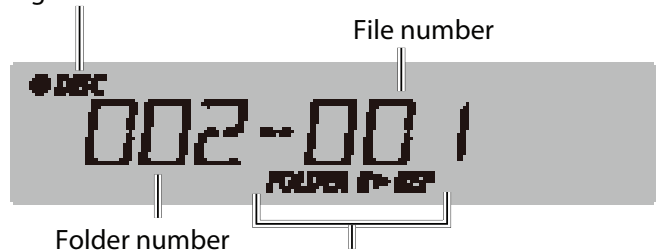

Folder number

File number

Play Mode indicators

Lights when each mode is activated.

Random play

Repeat play

Folder Repeat, Folder Scan

Display Change

Press [DISP].

Disc Player (CD-DA disc):

02 1'23 Track/Play time
d

THE BEST OF Disc title
d

LOVE ME FOR Track title
d

CD 8:15 AM Clock time
d

(Return to "Track/Play time")

Disc Player (MP3 disc):

002-001 Folder/File
d

2'35 Play time
d

THE BEST OF Folder name/ Album*
d

LOVE ME FOR File name/Title, artist*
d

MP3 8:15 AM Clock time
d

(Return to "Folder/File")

*ID3 Tag Setting

Hold down[3] (SCROLL) for more than 2 seconds.

TAG ON
cd

TAG OFF (Default)

When a folder name is displayed:

TAG ON: The album title is displayed.

TAG OFF: The folder name is displayed.

When a file name is displayed:

TAG ON: The title/artist name is displayed.

TAG OFF: The file name is displayed.

Notes

- i To have another circle scroll while a text is displayed, press [3] (SCROLL) . If the number of displayed characters is 11 or less, the characters do not scroll.
- i "NO TEXT" is displayed when no information exists on the disc.
- i ID3 tag information is displayed for the album name and title/artist name.

Random, Scan, Repeat Play

Random Play

All the available songs (tracks/files) are played in a random sequence.

Press [4] (RANDOM).  lights.

Press again to cancel.

Folder Random Play (MP3)

All the available files in the current folder are played in a random sequence.

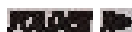
Hold down[4] (RANDOM) for more than 2 seconds.  lights.

Hold down again to cancel.

Scan Play

The first 10 seconds of each song (each track/file) is played in sequence.

Press [5] (SCAN) .

Press again to cancel.

Folder Scan Play (MP3)

From the next folder, the first 10 seconds of the first file in each folder is played in sequence.

Hold down[5] (SCAN) for more than 2 seconds.  lights.

Hold down again to cancel.

Repeat Play

The current song (track/file) is repeated.

Press [6] (REPEAT) .  lights.

Press again to cancel.

Folder Repeat Play (MP3)

The current folder is repeated.

Hold down[6] (REPEAT) for more than 2 seconds.  lights.

Hold down again to cancel.

Audio Settings

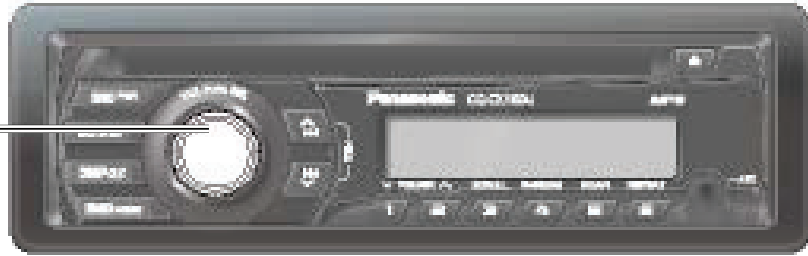

[VOL] selects a value in the audio menu.
 (PUSH SEL : Select)
 selects items in the audio menu.

1 Press [VOL] (PUSH SEL) to open the audio menu.

Note If no operation takes place for more than 5 seconds in audio setting (2 seconds in the volume adjustment), the display returns to the regular mode.

2 Press [VOL] (PUSH SEL) to select a mode to be adjusted.	3 Turn [VOL] clockwise (q) or counterclockwise (w) to adjust.
VOL 18 Volume (Setting Range: 0 to 40, Default: 18)	VOL 20 q / w : Adjustment
BASS Bass (Setting Range: -12 dB to +12 dB by 2 dB, Default: 0 dB)	BAS+ 5dB q / w : Adjustment
TREBLE Treble (Setting Range: -12 dB to +12 dB by 2 dB, Default: 0 dB)	TRE+ 5dB q / w : Adjustment
BALANCE Balance (Setting Range: 15 levels each, Default: CNT (center))	BAL L 15 q / w : Adjustment
FADER Fader (Setting Range: 15 levels each, Default: CNT (center))	FAD F 15 q / w : Adjustment

Notes

- i The volume can also be adjusted directly using [VOL] on the main unit. (a "General")
- i Do not activate SQ and Bass/Treble at the same time to avoid causing sound distortion.
- i If the fader is set to front, the pre-amp. output (rear) is decreased.

Troubleshooting

If You Suspect Something Wrong

Check and take steps as described below. If the described suggestions do not solve the problem, it is recommended to take the unit to your nearest authorized Panasonic Service Center. The product should be serviced only by qualified personnel. Please refer the checking and the repair to professionals. Panasonic shall not be liable for any accidents arising out of neglect of checking the unit or your own repair after your checking.

Never take measures especially those other than indicated by italic letters in "Possible Solution" described below because those are too dangerous for users to handle themselves.



Warning

- i Do not use the unit in an irregular condition, for example, without sound, or with smoke or a foul smell, which can cause ignition or electric shock. Immediately stop using the unit and consult your dealer.
- i Never try to repair the unit by yourself because it is dangerous to do so.

Trouble	Possible Solution
Common	
No power	<ul style="list-style-type: none"> i Start the engine. (Alternatively, turn the ignition switch to the ACC position.) i Verify the wiring. (Battery lead, power lead, ground lead, etc.) i Fuse blown (Consult your dealer or an authorized Panasonic Service Center.) i Ask a professional for fuse replacement. i Be sure to use the same rated fuse.
No sound	<ul style="list-style-type: none"> i Disable the mute function. i Verify the wiring. i Wait until the dew disappears before turning on the unit.
Noise	<ul style="list-style-type: none"> i Make sure that grounding is established properly.
No sound from left, right, front, or rear speaker	<ul style="list-style-type: none"> i Adjust the balance and fader. i Verify the wiring.
Left and right sounds are reversed	<ul style="list-style-type: none"> i Connect the speaker lead correctly.
Disc Player	
No sound, or disc is automatically ejected	<ul style="list-style-type: none"> i Load the disc correctly. i Clean the disc.
Sound skip, poor sound quality	<ul style="list-style-type: none"> i Clean the disc.
Sound skip due to vibration	<ul style="list-style-type: none"> i The maximum permissible tilt angle is 30°. i Secure the unit.
Disc not ejectable	<ul style="list-style-type: none"> i Press [u]. If the disc is still not ejected, consult your dealer or an authorized Panasonic Service Center.
Radio	
Frequent noise	<ul style="list-style-type: none"> i Tune in to another station of high-intensity waves. i Make sure that the antenna mounted point is grounded properly.
Preset data deleted	<ul style="list-style-type: none"> i The preset memory is cleared to return to the original factory setting when the power connector or battery is disconnected.

Error Display Messages

Display/Trouble	Possible Solution
Radio	
<p>No operation by some cause.</p>	<ul style="list-style-type: none"> i Switch the power or ACC ON/OFF. If this does not solve the problem or the unit is still out of order, consult your dealer or an authorized Panasonic Service Center to ask for repairs.
Disc Player	
<p>(The disc is ejected automatically.) The disc is dirty or upside down.</p>	<ul style="list-style-type: none"> i Check the disc.
<p>(The disc is ejected automatically.) The disc has scratches.</p>	<ul style="list-style-type: none"> i Check the disc.
<p>No operation by some cause</p>	<ul style="list-style-type: none"> i If normal operation is not restored, consult your dealer or an authorized Panasonic Service Center to ask for repairs.
<p>Cannot read the file</p>	<ul style="list-style-type: none"> i Check the disc.

Specifications

General

Power supply:	12 V DC (11 V – 16 V) test voltage 14.4 V, Negative ground
Current consumption:	Less than 2.2 A (CD mode, 0.5 W x 4 channels)
Maximum power output:	50 W x 4 channels (at 1 kHz), Vol- ume control maximum
Tone adjustment range	
Bass:	± 12 dB (at 100 Hz)
Treble:	± 12 dB (at 10 kHz)
Speaker impedance:	4 – 8 Ω
Pre-amp output voltage:	2.0 V (CD mode, 1 kHz, 0 dB)
Pre-amp output impedance:	200 Ω
Dimensions (W x H x D):	178 mm x 50 mm x 158 mm {7" x 1 15/16" x 6 1/4" }
Weight:	1.3 kg {2 lbs. 14 oz}
Front AUX input	
Input impedance:	10 kΩ
Maximum input level:	2.0 V
Connector:	3.5 mm ø Stereo mini pin
Input sensitivity:	200 mVrms

FM radio

Frequency range:	87.9 MHz – 107.9 MHz
Usable sensitivity:	11.0 dBf (75 Ω)
50 dB quieting sensitivity:	15.2 dBf (75 Ω)
Frequency response:	30 Hz – 15 kHz (±3 dB)
Alternate channel selectivity:	75 dB
Stereo separation:	35 dB (at 1 kHz)
Image rejection ratio:	55 dB
IF rejection ratio:	100 dB
Signal/noise ratio:	62 dB

AM radio

Frequency range:	530 kHz – 1 710 kHz
Usable sensitivity:	27 dB/μV (22 μV, S/N 20 dB)

CD player

Sampling frequency:	8 times oversampling
DA converter:	1 bit DAC System
Pick-up type:	Astigma 3-beam
Light source:	Semiconductor laser
Wavelength:	790 nm
Frequency response:	20 Hz – 20 kHz (±1 dB)
Signal to noise ratio:	96 dB
Total harmonic distortion:	0.01 % (1 kHz)
Wow and flutter:	Below measurable limits
Channel separation:	75 dB

Above specifications comply with EIA standards.

Notes

- i Specifications and design are subject to modification without notice due to improvements.
- i Some figures and illustrations in this manual may be different from your product.

Power Output:
16 W RMS x 4 Channels at 4 Ω and ≤ 1%
THD+N
Signal to Noise Ratio:
85 dBA (reference: 1 W into 4Ω)



© Panasonic Corporation 2014

**Panasonic Automotive
Systems Company of America,
Division of Panasonic
Corporation of North America
776 Highway 74 South, Peachtree
City, GA 30269**