

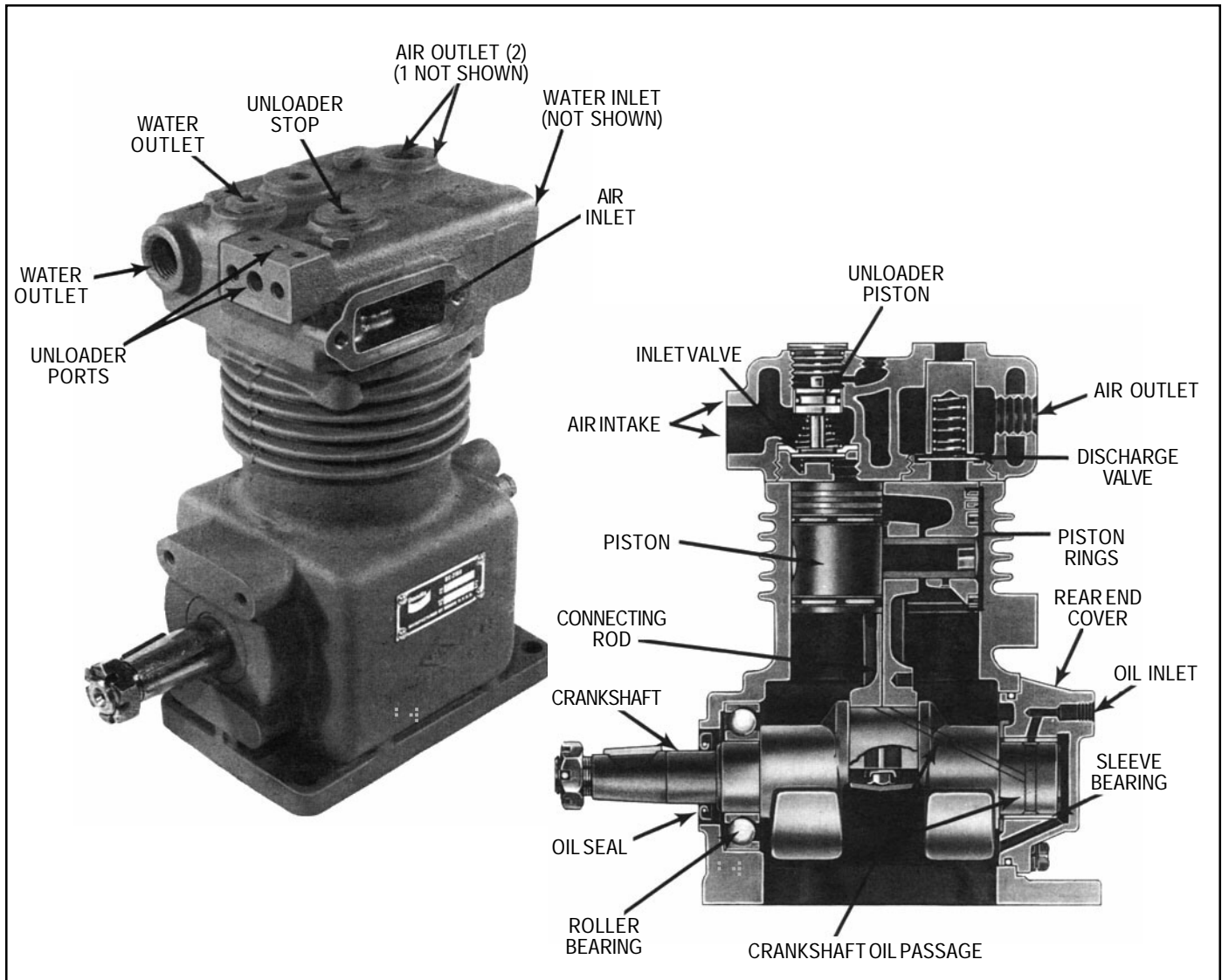

# Service Data

SD-01-331

## Bendix® BX-2150™ Air Compressor



BX-2150™ AIR COMPRESSOR BELT DRIVE MODEL

### DESCRIPTION

#### GENERAL

The function of the air compressor is to provide and maintain air under pressure to operate devices in the air brake and/or auxiliary air systems.

#### DESCRIPTION

The BX-2150™ compressor is a single cylinder, single stage reciprocating compressor with a rated displacement of 9.5

cubic feet per minute at 1250 R.P.M. The BX-2150™ compressor is constructed from two major assemblies, the cylinder head and the crankcase. The cylinder head is an iron casting containing the inlet, discharge and unloader valving. It is installed on the crankcase and is secured using four cap screws symmetrically placed. The cylinder head can be, therefore installed in any one of four different positions which are 90° apart.

Two governor mounting surfaces, adjacent to the single rectangular inlet cavity, provide a convenient means of mounting the governor to the cylinder head. One eighth inch

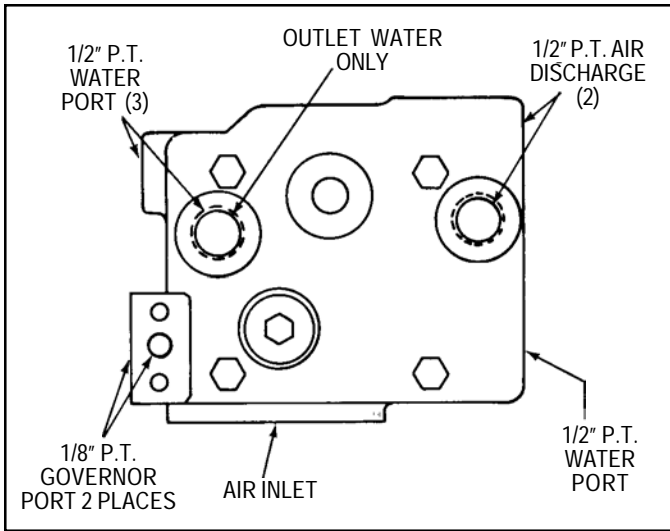

BX-2150™ COMPRESSOR CYLINDER HEAD

pipe threads in each of the two governor mounting pads allow plugging of the unused port or the installation of a tubing fitting for remote governor mounting. Three 1/2" N.P.T. ports provide the means for the connection of coolant lines and are labeled WATER. Two 1/2" N.P.T. discharge ports are located on the top and side of the cylinder head and are labeled AIR OUT.

The various mounting and drive configurations required by the numerous vehicle engine designs are accommodated by different crankcase castings and crankshafts.

Two methods for cooling the BX-2150™ compressor are employed. The cylinder head is water cooled using the engine's cooling system, while external fins on the crankcase provide a means for efficient air cooling in that area.

All BX-2150™ compressors utilize the engine's pressurized oil system to lubricate internal moving parts.

A nameplate attached to the compressor crankcase identifies the compressor model and is stamped to indicate the Bendix part number and serial number.

## OPERATION

### GENERAL

The compressor is driven by the vehicle engine and is operating continuously while the engine is running. Actual

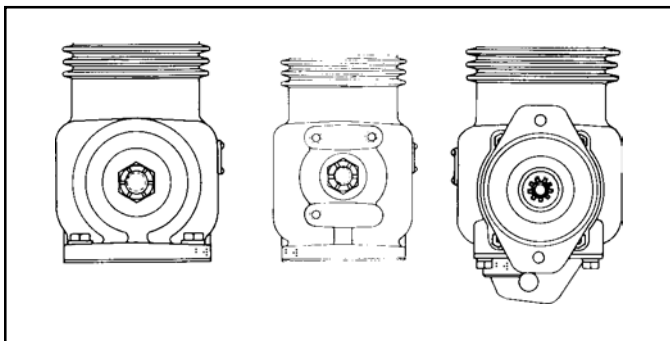

COMPRESSOR MOUNTING/DRIVE CONFIGURATIONS

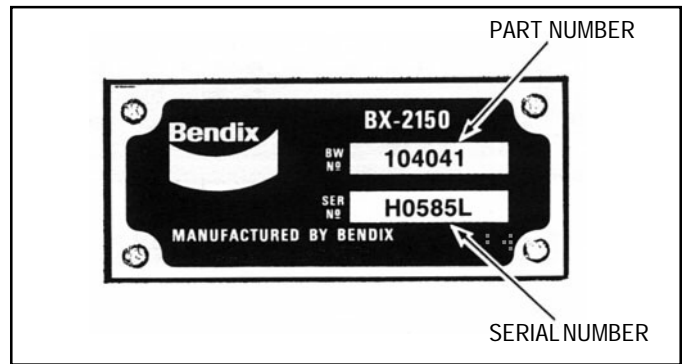

TYPICAL NAMEPLATE

compression of air is controlled by the compressor unloading mechanism and the governor. The governor is generally mounted on the compressor and maintains the brake system air pressure between a preset maximum and minimum pressure level.

### INTAKE AND COMPRESSION OF AIR (LOADED)

During the down stroke of the piston, a slight vacuum is created between the top of the piston and the head, causing the flat circular inlet valve to move off its seat. (Note the flat square discharge valve remains on its seat.) Atmospheric air is drawn into the intake cavity and flows past the open inlet valve and into the cylinder (See Figure 1). As the piston begins its upward stroke, the air that was drawn into the cylinder on the down strike is compressed. Air pressure on the inlet valve plus the force of its spring, returns the inlet valve to its seat. As the piston continues its upward stroke, air is compressed and forces the discharge valve away from its seat. Air flows past the open discharge valve into the discharge line and on to the reservoirs. (See Figure 2)

As the piston reaches the top of its stroke and starts down, the discharge valve spring and air pressure in the discharge line returns the discharge valve to its seat. This prevents the compressed air in the discharge line from returning to the

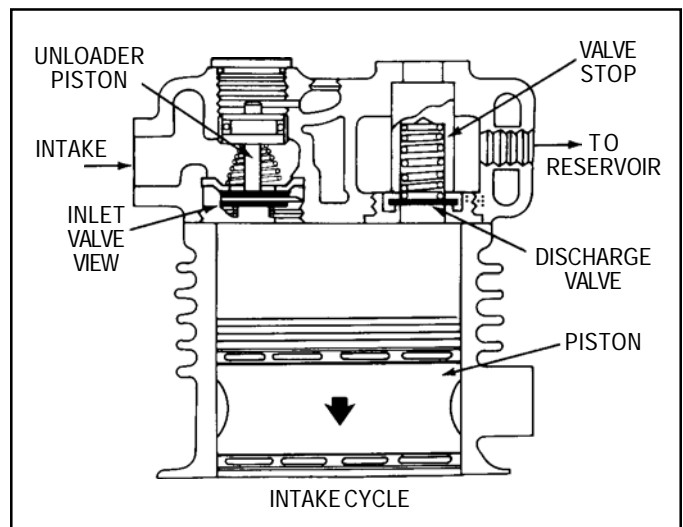

FIGURE 1

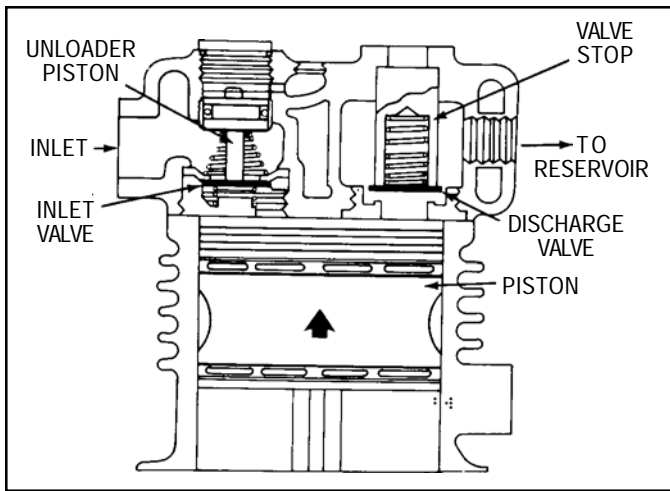

FIGURE 2 - COMPRESSION/DISCHARGE CYCLE

cylinder bore as the intake and compression cycle is repeated.

### NON-COMPRESSION OF AIR (UNLOADED)

When air pressure in the reservoir reaches the cut-out setting of the governor, the governor allows air to flow from the reservoir into the unloader piston cavity.

The unloader piston moves, in response to air pressure and drives the inlet valve away from its seat and holds it against its stop.

With the inlet valve held away from its seat, air compression is stopped and air is free to move back and forth past the inlet valve in response to piston travel. System pressure will eventually drop to the cut-in pressure setting of the governor due to air usage. When the cut-in pressure is reached, the governor responds by exhausting air from the unloader piston cavity. Spring force moves the unloader piston away from the inlet valve and compression is resumed as the inlet valve returns to its seat.

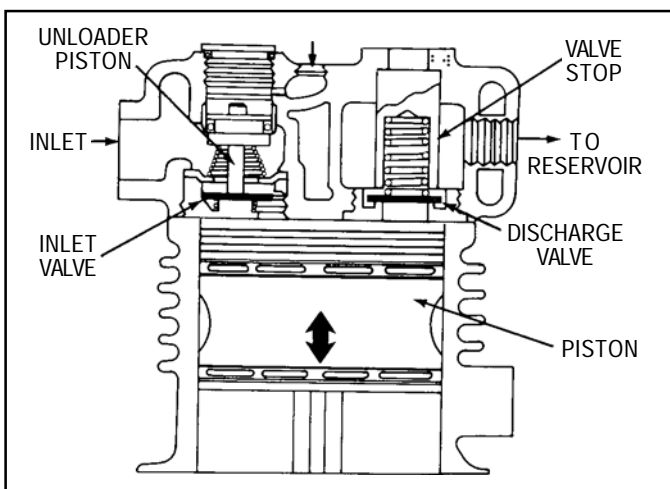

FIGURE 3 - UNLOADED CYCLE

## COMPRESSOR & THE AIR BRAKE SYSTEM

### GENERAL

The compressor is part of the total air brake system, more specifically, the charging portion of the air brake system. As a component in the overall system its condition, duty cycle, proper installation and operation will directly affect other components in the system.

Powered by the vehicle engine, the air compressor builds the air pressure for the air brake system. The air compressor is typically cooled by the engine coolant system, lubricated by the engine oil supply and has its inlet connected to the engine induction system.

As the atmospheric air is compressed, all the water vapor originally in the air is carried along into the air system, as well as a small amount of the lubricating oil as vapor. If an air dryer is not used to remove these contaminants prior to entering the air system, the majority, but not all, will condense in the reservoirs. The quantity of contaminants that reach the air system depends on several factors including installation, maintenance and contaminant handling devices in the system. These contaminants must either be eliminated prior to entering the air system or after they enter.

### DUTY CYCLE

The duty cycle is the ratio of time the compressor spends building air to the total engine running time. Air compressors are designed to build air (run "loaded") up to 25% of the time. Higher duty cycles cause conditions that affect air brake charging system performance which may require additional maintenance. Factors that add to the duty cycle are: air suspension, additional air accessories, use of an undersized compressor, frequent stops, excessive leakage from fittings, connections, lines, chambers or valves, etc. Refer to Table A in the Troubleshooting section for a guide to various duty cycles and the consideration that must be given to maintenance of other components.

### COMPRESSOR INSTALLATION

While the original compressor installation is usually completed by the vehicle manufacturer, conditions of operation and maintenance may require additional consideration. The following presents base guidelines.

### DISCHARGE LINE

The discharge line allows the air, water-vapor and oil-vapor mixture to cool between the compressor and air dryer or reservoir. The typical size of a vehicle's discharge line, (see column 2 of Table A in the Troubleshooting section) assumes a compressor with a normal (less than 25%) duty cycle, operating in a temperate climate. See Bendix and/or other air dryer manufacturer guidelines as needed.

The discharge line must maintain a constant slope down from the compressor to the air dryer inlet fitting or reservoir to avoid low points where ice may form and block the flow. If,

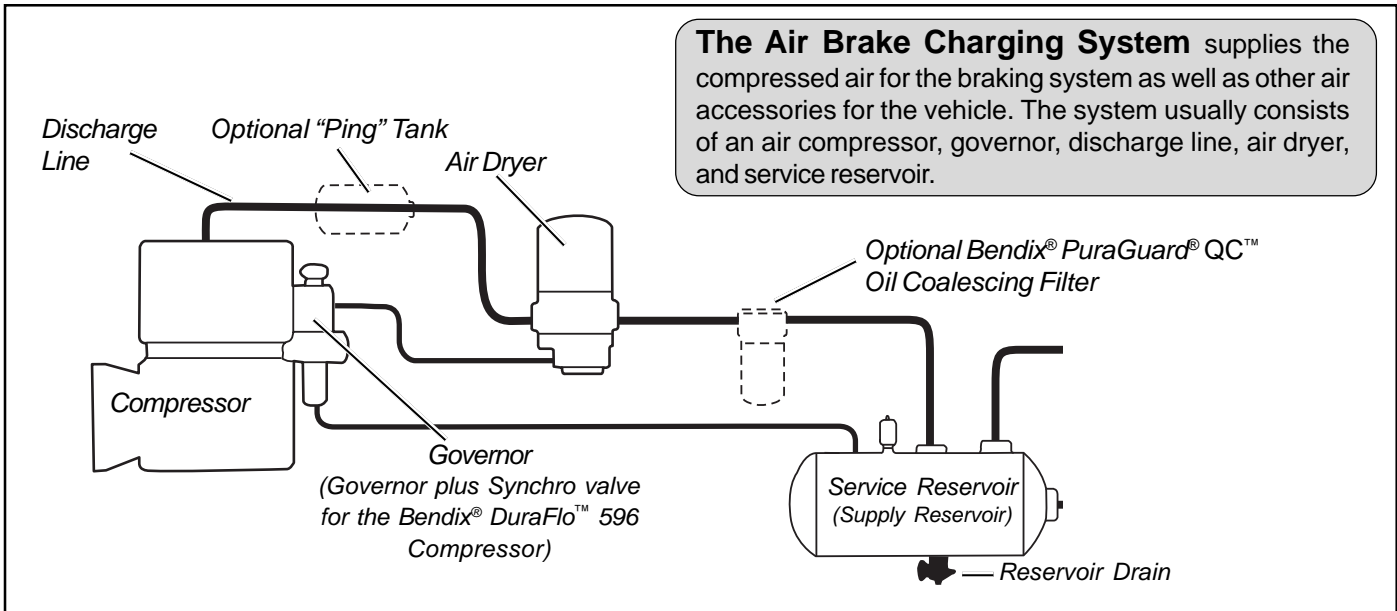

FIGURE 4A - SYSTEM DRAWING

instead, ice blockages occur at the air dryer or reservoir inlet, insulation may be added here, or if the inlet fitting is a typical 90 degree fitting, it may be changed to a straight or 45 degree fitting. Shorter discharge line lengths or insulation may be required in cold climates.

While not all compressors and charging systems are equipped with a discharge line safety valve this component is recommended. The discharge line safety valve is installed in the cylinder head or close to the compressor discharge port and protects against over pressurizing the compressor in the event of a discharge line freezeup.

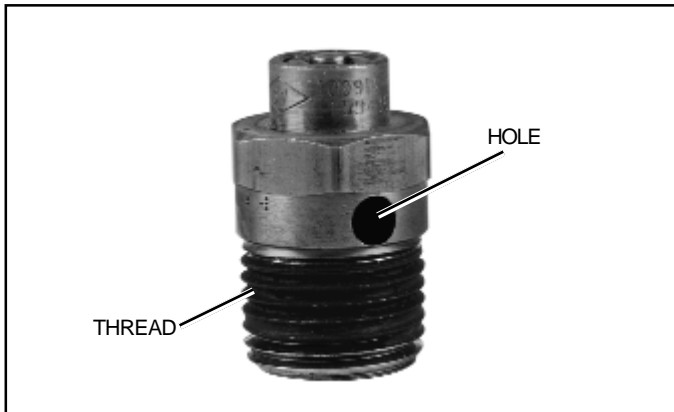

FIGURE 4B - DISCHARGE LINE SAFETY VALVE

**DISCHARGE LINE TEMPERATURE**

When the temperature of the compressed air that enters the air dryer is within the normal range, the air dryer can remove most of the charging system oil. If the temperature of the compressed air is above the normal range, oil as oil-vapor is able to pass through the air dryer and into the air system. Larger diameter discharge lines and/or longer discharge line lengths can help reduce the temperature.

The air dryer contains a filter that collects oil droplets, and a desiccant bed that removes almost all of the remaining water vapor. The compressed air is then passed to the air brake service (supply) reservoir. The oil droplets and the water collected are automatically purged when the governor reaches its "cut-out" setting.

For vehicles with accessories that are sensitive to small amounts of oil, we recommend installation of a Bendix® PuraGuard® QC™ oil coalescing filter, designed to minimize the amount of oil present.

**LUBRICATION**

All BX-2150™ compressors are connected to the engine's pressurized oil system and a continuous flow of oil is provided to the compressor, which is eventually returned to the engine.

Oil is fed into the compressor in various ways, for example; through the rear end cover or the drive end of the crankshaft. An oil passage in the crankshaft conducts pressurized oil to the precision sleeve main bearings and to the connecting rod bearing.

The cylinder bore, connecting rod wrist pin bushing and ball type main bearing, where used, are splash lubricated. Splash lubrication is obtained as oil is forced out around the crankshaft journals by engine oil pressure. See the tabulated technical data in the back of this manual for specific requirements.

## COOLING

Air flowing through the engine compartment from the action of the engine's fan and the movement of the vehicle assists in cooling the crankcase. Coolant flowing from the engine's cooling system through connecting lines enters the head and passes through the head's water jacket and back to the engine. Proper cooling is important in maintaining discharge air temperatures below the maximum 400°F recommended.

Figure 5 illustrates the various approved coolant flow directions. See the tabulated technical data in the back of this manual for specific requirements.

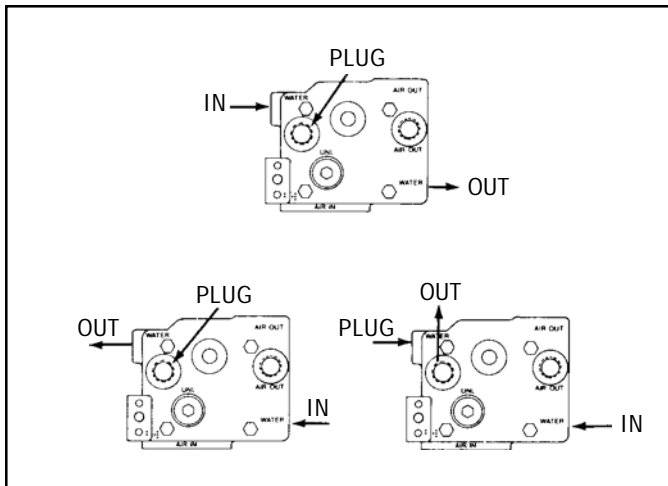

FIGURE 5 - WATER CONNECTIONS/FLOW

## AIR INDUCTION

### GENERAL

There are three methods of providing clean air to the BX-2150™ compressor;

1. Naturally aspirated Local Air Strainer - Compressor utilizes its own attached air strainer (polyurethane sponge or pleated paper dry element).
2. Naturally aspirated Engine Air Cleaner - Compressor inlet is connected to the engine air cleaner or the vacuum side (engine air cleaner) of the supercharger or turbocharger.
3. Pressurized induction - Compressor inlet is connected to the pressure side of the supercharger or turbocharger.

See the tabulated technical data in the back of this manual for specific requirements for numbers 2 and 3 above.

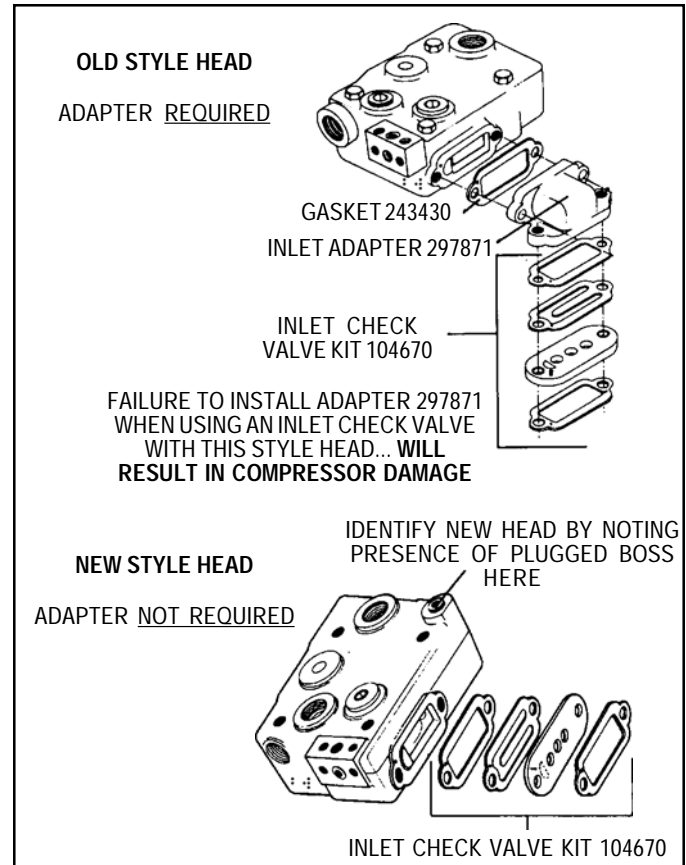

FIGURE 6

### INLET CHECK VALVE

An inlet check valve is used on some naturally aspirated BX-2150™ compressors (never with pressurized induction, see #3 above) to prevent inlet oil misting during the unloaded cycle.

The new style BX-2150™ compressor head (See Figure 6) can be identified by the plugged boss on the upper right hand side. This head only requires kit 104670 to install an inlet check valve. All other old style BX-2150™ compressor heads (See Figure 6) require the use of the inlet adapter 297871 and inlet gasket 243430 in addition to the kit 104670.

### WARNING!

**FAILURE TO INSTALL ADAPTER 297871 WHEN REQUIRED WILL RESULT IN COMPRESSOR DAMAGE.**

The inlet check valve consists of three parts, the inlet gasket, the inlet check valve reed and the inlet check valve seat (See Figure 6) during the compression cycle, the inlet check valve reed is drawn away from its seat uncovering three inlet holes which allows air to flow into the compressor inlet cavity. A machined stop in the cylinder head inlet cavity or in the inlet adapter 297871 limits the travel of the inlet check valve reed. In the unloaded cycle, the inlet check valve reed rests on its seat covering the three inlet holes. Air from within the compressor is prevented from exiting the inlet cavity.

Inlet gasket 243430 is required between the inlet check valve reed and the inlet cavity of new style heads, or between the inlet check valve reed and the inlet adapter 297871 for old style heads, as its thickness contributes to the minimum reed travel required. The pin in the check valve seat must align with the holes in the check valve, the inlet gasket and enter the mating hole in the head or the inlet adapter. (Refer to Figure 6)

**CAUTION:** If ICV is used with air dryer/aftercooler which vents the discharge line during its purge cycle, a PR-4™ valve (P/N 103976) is recommended to be installed in the discharge line to minimize oil passing which can occur in the combined use of an ICV and a vented discharge line. See Bulletin No. PRO-08-13 for proper installation of the PR-4™ valve.

**PREVENTATIVE MAINTENANCE**

Regularly scheduled maintenance is the single most important factor in maintaining the air brake charging system. Refer to Table A in the Troubleshooting section for a guide to various considerations that must be given to the maintenance of the compressor and other related charging system components.

**AIR INDUCTION**

One of the single most important aspects of compressor preventive maintenance is the induction of clean air. The type and interval of maintenance required will vary depending upon the air induction system used.

The intervals listed under the headings below pertain to typical highway and street operation. More frequent maintenance will be required for operation in dusty or dirty environments.

**POLYURETHANE SPONGE STRAINER**

Every month, 150 operating hours or 5,000 miles, whichever occurs first, remove and wash all of the parts.

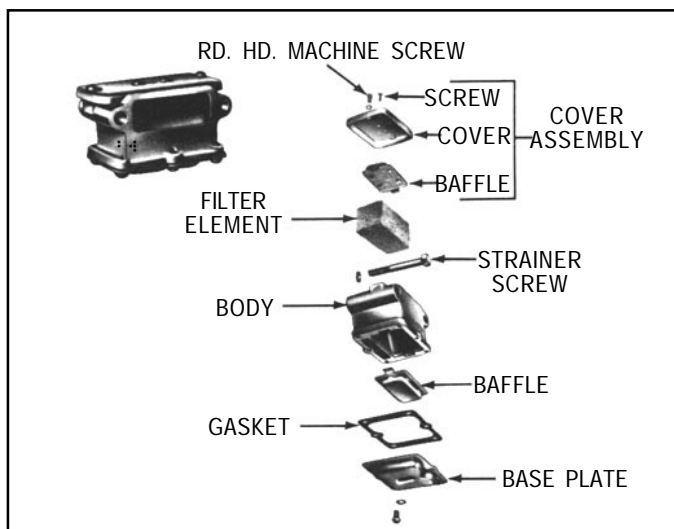

FIGURE 7

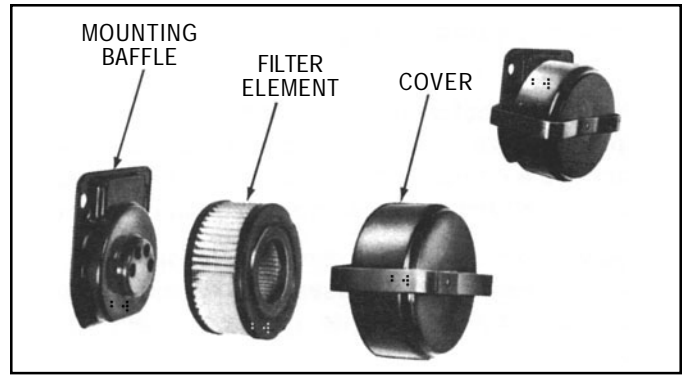

FIGURE 8

The strainer element should be cleaned or replaced. If the element is cleaned, it should be washed in a commercial solvent or a detergent and water solution. The element should be saturated in clean engine oil, then squeezed dry before replacing it in the strainer. Be sure to replace the air strainer gasket if the entire air strainer is removed from the compressor intake.

**DRY ELEMENT-PLEATED PAPER AIR STRAINER**

Every two months, 800 operating hours or 20,000 miles whichever occurs first, remove the spring clips from either side of mounting baffle and remove the cover. Replace the pleated paper filter and remount the cleaned cover making sure the filter is in position. Make certain to replace the air strainer gasket if the entire air strainer is removed from the compressor intake.

**INTAKE ADAPTER**

When the engine air cleaner is replaced; Some compressors are fitted with intake adapters which allow the compressor intake to be connected to the engine air cleaner, turbo or super-charger. In this case, the compressor receives a supply of clean air from the engine air cleaner. When the engine air filter is changed, the compressor intake adapter should be checked. If it is loose, remove the intake adapter, clean the strainer plate, if applicable, and replace the intake adapter gasket, and reinstall the adapter securely. Check line connections both at the compressor intake adapter and at the engine or engine air cleaner. Inspect the connecting line for kinks and ruptures and replace it if necessary.

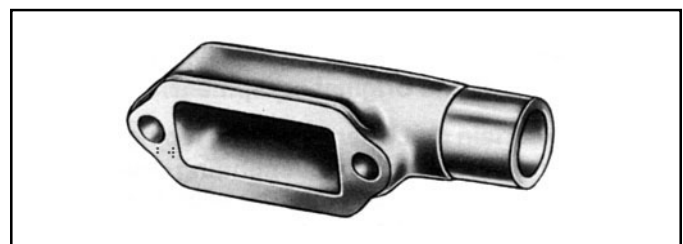

FIGURE 9 - COMPRESSOR INTAKE ADAPTER

## COMPRESSOR COOLING

Every six months, 1800 operating hours or 50,000 miles, whichever occurs first, inspect the compressor discharge port, inlet cavity and discharge line for evidence of restrictions and carboning. If excessive buildup is noted, thoroughly clean or replace the affected parts and closely inspect the compressor cooling system. Check all compressor coolant lines for kinks and restrictions to flow. **Minimum** coolant line size is 3/8" I.D. Check coolant lines for internal clogging from rust scale. If coolant lines appear suspicious, check the coolant flow and compare to the tabulated technical data present in the back of this manual.

Inspect and clean the external air cooling fins on the cylinder portion of the crankcase. If fins are cracked or broken, replace the compressor.

Inspect the air induction system for restrictions.

## LUBRICATION

Every six months, 1800 operating hours or 50,000 miles, whichever occurs first; check external oil supply and return lines, if applicable, for kinks, bends, or restrictions to flow. Supply lines must be a minimum of 3/16" I.D. and return lines must be a minimum of 1/2" I.D. Oil return lines should slope as sharply as possible back to the engine crankcase and should have as few fittings and bends as possible. Refer to the tabulated technical data in the back of this manual for oil pressure minimum valves.

Check the exterior of the compressor for the presence of oil seepage and refer to the TROUBLESHOOTING section for appropriate tests and corrective action.

## OIL PASSING

All reciprocating compressors currently manufactured will pass a minimal amount of oil. Air dryers will remove the majority of oil prior to entrance into the air brake system. For particularly oil sensitive systems the Bendix® PuraGuard® QC™ oil coalescing filter can be used in conjunction with a Bendix air dryer.

If compressor oil passing is suspected, refer to the TROUBLESHOOTING section and TABLE A for the symptoms and corrective action to be taken. In addition, Bendix has developed the "**Bendix Air System Inspection Cup**" or **BASIC** test to help substantiate suspected excessive oil passing. The steps to be followed when using the BASIC test are presented in APPENDIX A at the end of the TROUBLESHOOTING section.

## COMPRESSOR DRIVE

Every six months, 1800 operating hours or 50,000 miles, whichever occurs first, check for noisy compressor operation. Variations in noise level in conjunction with the compression and unloaded cycles generally indicate loose or worn drive components.

On belt drive compressors check for pulley and belt alignment and tension. Adjust as necessary, paying particular attention not to overtighten belt tension. Check for loose and out of aligned pulleys. Adjust or replace as necessary. Compressor crankshaft keyway damage indicates a loose pulley and often requires compressor replacement. Main bearing failures on belt driven compressors often indicate excessive belt tension.

A thorough inspection, and possible replacement, of drive components should be made at each compressor change. Special attention should be given to drive gears and couplings on compressors which have been operated at high discharge pressures due to a blocked or frozen discharge line.

Check all compressor mounting bolts and retighten evenly as necessary. Check the condition of all compressor mounting bracketry, tighten hardware as necessary, and replace if damaged.

## OPERATIONAL TESTS

Every three months, 900 operating hours or 25,000 miles whichever occurs first. Vehicles manufactured after the effective date of FMVSS 121, with the minimum required reservoir volume, must have a compressor capable of raising air system pressure from 85-100 p.s.i. in 25 seconds or less. This test is performed with the engine operating at maximum governed speed. The vehicle manufacturer must certify this performance on new vehicles with appropriate allowances for air systems with greater than the minimum required reservoir volume.

Check unloader operation by building system pressure to governor cut-out and note that air compression stops. Reduce system pressure to governor cut-in and note that air compression resumes. If the compressor fails to respond as described, make certain the governor is functioning properly before repairing or replacing the compressor.

## COMPRESSOR AIR LEAKAGE TESTS

Compressor leakage tests need not be performed on a regular basis. These tests should be performed when; it is suspected that discharge valve leakage is substantially affecting compressor build-up performance, or when it is suspected that the compressor is "cycling" between the load and unloaded modes due to unloader piston leakage.

These tests must be performed with vehicle parked on a level surface, the engine not running, the entire air system completely drained to 0 P.S.I., and the inlet check valve detail parts removed, if applicable.

## UNLOADER PISTON LEAKAGE

Remove the governor and apply shop air pressure to the 1/8" pipe thread unloader port on the governor mounting pad. Listen for the escape of air at the inlet cavity. An audible escape of air should not be detected. If any question exists

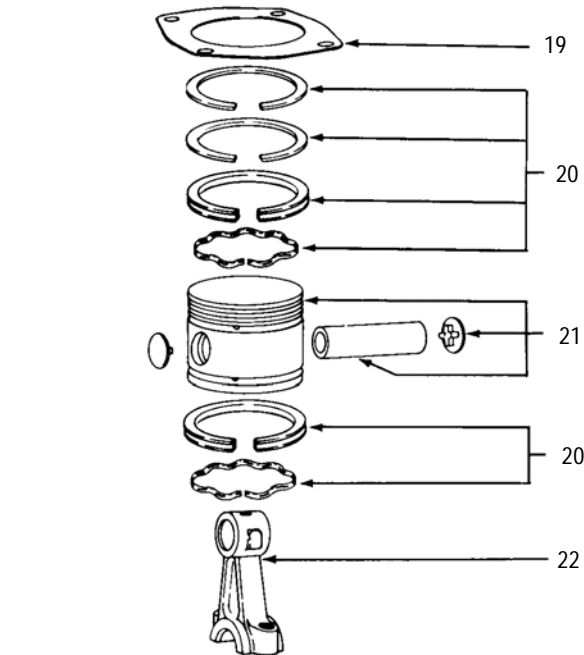
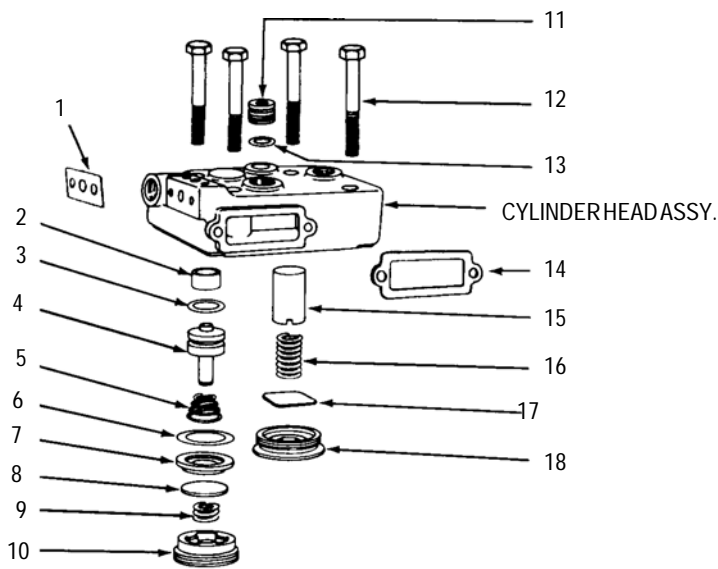

NO.	DESCRIPTION
	Cylinder Head Assembly
1	Governor Gasket
2	Unloader Bushing
3	O-Ring
4	Unloader Piston
5	Unloader Spring
6	Inlet Valve Gasket
7	Inlet Valve Seat
8	Inlet Valve
9	Inlet Valve Spring
10	Inlet Valve Stop
11	Unloader Piston Stop
12	Hex Head Screws
13	O-Ring
14	Inlet Strainer Gasket
15	Discharge Valve Stop
16	Discharge Valve Spring
17	Discharge Valve
18	Discharge Valve Seat
19	Cylinder Head Gasket
20	Piston Ring Set (STD)
	#1 Piston Ring
	#2 Piston Ring
	Piston Ring Oil Expander Ring
21	Piston
	Wrist Pin Plug
	Wrist Pin
22	Connecting Rod
	Connecting Rod Cap
	Lockwasher
	Connecting Rod Bolt
23	O-Ring
24	Thrust Washer
25	End Cover Assembly

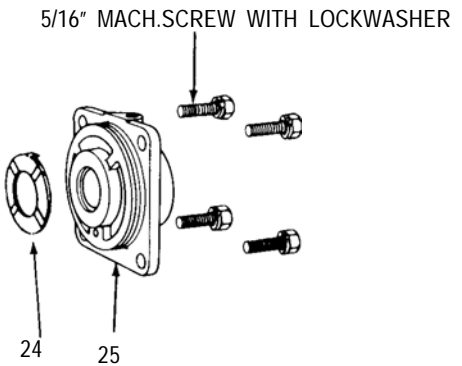
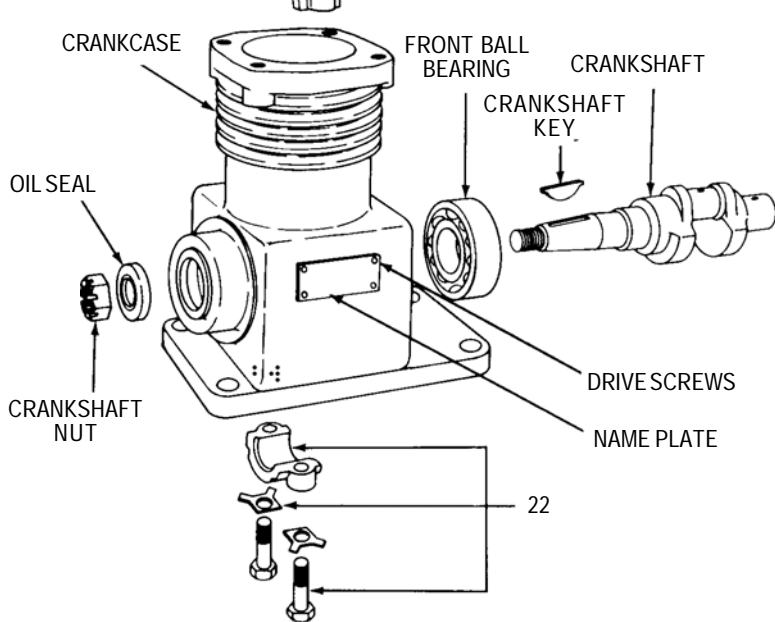

NOTE: SOME APPLICATIONS USE FRONT AND REAR REF. SOME FLANGE MOUNTS WITHOUT BALL BEARINGS.



as to leakage, it is recommended that a genuine Bendix unloader kit be installed and the cylinder head retested.

## **DISCHARGE VALVE LEAKAGE**

Unloader piston leakage must be repaired before this test is performed. Leakage past the discharge valve can be detected by removing the discharge line, applying shop air to the unloader mechanism and the discharge port and listening for the escape of air at the compressor inlet cavity. A barely audible escape of air is generally acceptable; however, if there is any question as to the leakage rate, it is recommended that the cylinder head or compressor be removed and repaired or replaced. With shop air still applied at the discharge port, apply a soap solution to the valve stop recess on the top of the head. If leakage is detected, the cylinder head must be repaired or replaced. Only genuine Bendix remanufactured compressors or service parts and kits should be used.

## **COMPRESSOR TROUBLESHOOTING**

**IMPORTANT:** The troubleshooting contained in this section considers the compressor as an integrated component of the overall air brake charging system and assumes that an air dryer is in use. The troubleshooting presented will cover not only the compressor itself, but also other charging system devices as they relate to the compressor.

### **WARNING! PLEASE READ AND FOLLOW THESE INSTRUCTIONS TO AVOID PERSONAL INJURY OR DEATH:**

**When working on or around a vehicle, the following general precautions should be observed at all times.**

- 1. Park the vehicle on a level surface, apply the parking brakes, and always block the wheels. Always wear safety glasses.**
- 2. Stop the engine and remove ignition key when working under or around the vehicle. When working in the engine compartment, the engine should be shut off and the ignition key should be removed. Where circumstances require that the engine be in operation, EXTREME CAUTION should be used to prevent personal injury resulting from contact with moving, rotating, leaking, heated or electrically charged components.**
- 3. Do not attempt to install, remove, disassemble or assemble a component until you have read and thoroughly understand the recommended procedures. Use only the proper tools and observe all precautions pertaining to use of those tools.**
- 4. If the work is being performed on the vehicle's air brake system, or any auxiliary pressurized air systems, make certain to drain the air pressure from all reservoirs before beginning ANY work on the vehicle. If the vehicle is equipped with an AD-IS™ air dryer system or a dryer reservoir module, be sure to drain the purge reservoir.**

- 5. Following the vehicle manufacturer's recommended procedures, deactivate the electrical system in a manner that safely removes all electrical power from the vehicle.**
- 6. Never exceed manufacturer's recommended pressures.**
- 7. Never connect or disconnect a hose or line containing pressure; it may whip. Never remove a component or plug unless you are certain all system pressure has been depleted.**
- 8. Use only genuine Bendix® replacement parts, components and kits. Replacement hardware, tubing, hose, fittings, etc. must be of equivalent size, type and strength as original equipment and be designed specifically for such applications and systems.**
- 9. Components with stripped threads or damaged parts should be replaced rather than repaired. Do not attempt repairs requiring machining or welding unless specifically stated and approved by the vehicle and component manufacturer.**
- 10. Prior to returning the vehicle to service, make certain all components and systems are restored to their proper operating condition.**
- 11. For vehicles with Antilock Traction Control (ATC), the ATC function must be disabled (ATC indicator lamp should be ON) prior to performing any vehicle maintenance where one or more wheels on a drive axle are lifted off the ground and moving.**

## **COMPRESSOR REMOVAL & DISASSEMBLY**

### **GENERAL**

The following instructions are presented here for reference. Removal and disassembly of the compressor is not recommended unless the appropriate service parts and/or kits are on hand.

### **REMOVAL**

These instructions are general and are intended to be a guide, in some cases additional preparations and precautions are necessary.

- 1. Block the wheels of the vehicle and drain the air pressure from all the reservoirs in the system.**
- 2. Drain the engine cooling system and the cylinder head of the compressor. Identify and disconnect all air, water and oil lines leading to and from the compressor.**
- 3. Remove the governor and any supporting bracketry attached to the compressor and note their positions on the compressor to aid in reassembly.**
- 4. Remove the discharge port and inlet cavity fittings, if applicable, and note their position on the compressor to aid in reassembly.**
- 5. Remove the flange or base mounting bolts and remove the compressor from the vehicle.**

6. Remove the drive gear(s) or pulley from the compressor crankshaft using a gear puller. Inspect the pulley or gear and associated parts for visible wear or damage. Since these parts are precision fitted, they must be replaced if they are worn or damaged.

## PREPARATION FOR DISASSEMBLY

Remove road dirt and grease from the exterior of the compressor with a cleaning solvent. Before the compressor is disassembled, the following items should be marked to show their relationship when the compressor is assembled. Mark the rear end cover in relation to the crankcase. Mark the cylinder head in relation to the crankcase. Mark the base plate or base adapter in relation to the crankcase.

A convenient method to indicate the above relationship is to use a metal scribe to mark the parts with numbers or lines. Do not use a marking method that can be wiped off or obliterated during rebuilding, such as chalk. Remove all compressor attachments which have not been previously specified.

## CYLINDER HEAD DISASSEMBLY

Remove the four cylinder head cap screws and tap the head with a soft mallet to break the gasket seal. Scrape off any gasket material from the cylinder head and crankcase.

Before disassembling the discharge valve mechanism, measure and record the discharge valve travel (from closed to completely open).

1. If the measured discharge valve travel DOES NOT EXCEED .032 inches, the discharge valve stop need not be removed. It is recommended that the cylinder head body be replaced if the discharge valve stop requires replacement. In the event this is not possible the following procedure can be followed: Using a 9/16" Allen wrench, remove the discharge valve seat, valve, and valve spring.

To remove the discharge valve stop, support the machined surface of the cylinder head on an arbor press bed and gently press the stop from the top of the head and out the bottom. Be sure to allow sufficient clearance for the stop between the press bed and the bottom of the cylinder head. The valve stop bore in the cylinder head must be inspected for excessive scoring. A new cylinder head body must be used if scoring is excessive.

2. Remove the unloader stop and o-ring.
3. Remove the unloader piston and o-ring.
4. Insert the lugs of a spanner wrench into the holes of the inlet valve stop and remove the inlet valve stop along with the inlet valve, valve seat, unloader gasket and spring. (NOTE: Reference **Williams** adjustable face spanner #483.)
5. Inspect the unloader piston bushing for nicks, wear, corrosion and scoring. It is recommended that the

cylinder head body be replaced if it is determined that the unloader piston bushing requires replacement. If this is not possible, the bushing can be pressed out of the head using the same procedure presented in Step 2 of this disassembly section. NOTE: *if the bushing is pressed out and the cylinder head casting is damaged in the process, cylinder head repair is not recommended* Pressing in the replacement bushing will result in air or water leakage.

## CRANKCASE BASE PLATE OR ADAPTER DISASSEMBLY

1. Remove the cap screws securing the base plate or base adapter. Tap with soft mallet to break the gasket seal. Scrape off any gasket material from crankcase and plate adapter.

## CONNECTING ROD DISASSEMBLY

Before removing the connecting rod, mark the connecting rod and its cap. The connecting rod is matched to its own cap for proper fit, and the cap must be reinstalled in the same position on the rod.

1. Straighten the prongs of the connecting rod bolt locks and remove the bolts and bearing cap.
2. Push the piston with the connecting rod attached out the top of the cylinder of the crankcase. Replace the bearing cap on the connecting rod.
3. Remove the piston rings from the piston. If the piston is to be removed from the connecting rod, remove the wrist pin teflon plugs and press the wrist pin from the piston and connecting rod.
4. If the piston is removed from the rod, inspect the wrist pin bore or the bronze wrist pin bushing in the connecting rod. If excessive wear is noted or suspected, replace the connecting rod.

## COMPRESSOR CRANKCASE DISASSEMBLY

1. Remove the key or keys from the crankshaft and any burrs from the crankshaft where the key or keys were removed. (NOTE: *Through drive compressors may have a crankshaft key at both ends.*)
2. Remove the four cap screws and lockwashers or nuts and lockwashers that secure the rear end cover to the crankcase.
3. Remove the rear end cover, thrust bearing and end cover o-ring taking care not to damage the bearing if present in the end cover.
4. If the compressor has ball type main bearings, press the crankshaft and ball bearings from the crankcase, then press the ball bearings from the crankshaft.
5. Press the oil seal out of the compressor crankcase if so equipped.

## CLEANING OF PARTS

### GENERAL

All parts should be cleaned in a good commercial grade solvent and dried prior to inspection.

### CYLINDER HEAD

Remove carbon deposits from the discharge cavity and rust and scale from the cooling cavities of the cylinder head body. Scrape all foreign matter from the body surfaces and use shop air pressure to blow the dirt particles from the cavities.

Clean carbon and dirt from the inlet and unloader passages. Use shop air to blow the carbon and dirt deposits from the unloader passages.

### OIL PASSAGES

Thoroughly clean all oil passages through the crankshaft, crankcase, end covers, and base plate or base adapter. Inspect the passages with a wire to be sure they are clear. Blow the loosened foreign matter out with shop air.

## INSPECTION OF PARTS

### CYLINDER HEAD BODY

Inspect the cylinder head for cracks and obvious physical damage. Pay particular attention to the area around coolant ports for cracks. Check for stripped or damaged threads. Apply shop air pressure to one of the coolant ports with all others plugged, and check for leakage by applying a soap solution to the exterior of the body. If leakage is detected, replace the head.

### END COVERS

Check for cracks, stripped oil port threads and external damage; and if noted, replace the end cover. If the crankshaft main bearings are installed in the end cover, check for excessive wear and flat spots and replace the end cover if necessary.

### CRANK CASE

Check all crankcase surfaces for cracks and damage. Pay particular attention to cooling fins. On compressors where ball bearing main bearings are used the difference between the O.D. of the outer race and the I.D. of the crankcase hole should be .0000 inch to .0015 inch loose. This is to maintain the correct press fit. The crankcase must be replaced if the fit is too loose.

On compressors fitted with precision, sleeve main bearings the difference between the O.D. of the crankshaft journal and the main bearing I.D. must not exceed .004 inch, or the end cover and main bearing must be replaced.

The cylinder bore should be checked with inside micrometers or calipers. Cylinder bores which are scored or out of round by more than .0005 inch or tapered more than .0005 inch should be rebored or honed oversize. Oversized pistons and piston rings are available in .010 inch, .020 inch and .030 inch oversizes. The cylinder bore must be smooth, straight, and round.

## PISTONS

Check the piston for scores, cracks, or enlarged ring grooves; replace the piston if any of these conditions are found. Measure the diameter of the top of the piston and the top two ring lands. (Compare to cylinder bore and piston diameters to be sure the diametrical clearance is between .0128 inch minimum and .0177 inch maximum.)

Check the fit of the wrist pin to the piston. The wrist pin should be a light press fit in the piston. This clearance should not exceed .0006 inch. If the wrist pin is a loose fit, the piston and pin assembly should be replaced. Check the fit of the wrist pin in the connecting rod by rocking the piston. Conn rod wrist pin .0009 max. Replace the connecting rod if excessive clearance is found. **NOTE:** *Wrist pin bushing replacement is not recommended for those connecting rods which incorporate them.*

Check the fit of the piston rings in the piston ring grooves. Check the ring gap with the rings installed in the cylinder bores. Refer to Figure 11 for correct gap and groove clearances.

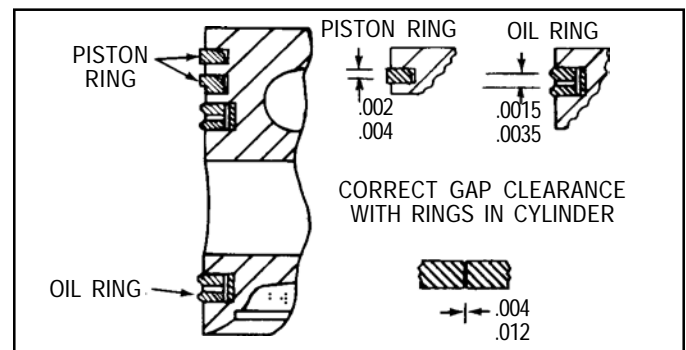

FIGURE 11 - CORRECT GROOVE CLEARANCE

## CRANKSHAFT

Check the crankshaft threads, keyways, tapered ends and all machined and ground surfaces for wear, scores, or damage. Standard crankshaft connecting rod journals are between 1.2500 inches and 1.249 inches in diameter. If the crankshaft journals are excessively scored or worn or out of round, the crankshaft must be replaced. Main bearing journals must be maintained so the ball bearings are a snug fit or so that no more than .004 inch clearance exists between the precision sleeve main bearing and the main bearing journals on the crankshaft. In crankshafts fitted with oil seal rings, the oil seal ring groove or grooves must not be worn. The ring groove walls must have a good finish and they must be square. Using a wire or similar device, check to be sure the oil passages are open through the crankshaft.

## CONNECTING RODS

The BX-2150™ compressor connecting rod does not incorporate replaceable crankshaft journal bearing inserts and must be replaced if excessively worn. Clearance between the crankshaft journal and the connecting rod bearing must not be less than .001 inch or more than .0025 inches.

## REPAIRS

It is generally recommended that genuine Bendix service parts and maintenance kits be used whenever the compressor is disassembled. A listing of the most common kits and their contents can be found in the back of this manual.

## ASSEMBLY

### TORQUES

All torques specified in this manual are assembly torques and can be expected to fall off after assembly is accomplished. **Do not retorque** after initial assembly torques fall.

To convert pound inches of torque to pound feet of torque, divide inch pounds by 12.

$$\frac{\text{pound inches}}{12} = \text{pound feet}$$

12

To convert pound feet of torque to pound inch of torque, multiply pound feet by 12.

$$\text{pound feet} \times 12 = \text{pound inches}$$

### CYLINDER HEAD ASSEMBLY

1. If the discharge valve stop was removed and must be replaced, a sealant such as "LOCKTITE RETAINING COMPOUND #75", must be applied to the stop and its corresponding bore in the cylinder head. Before applying the sealant, make certain that the press fit between the discharge valve stop outside diameter and the valve stop bore in the cylinder head is a minimum of .0013 inches and a maximum of .0028 inches. If this fit cannot be maintained, a new cylinder head body must be used. Be sure to completely support the outside top of the cylinder head casting, while pressing in the replacement stops.

**IMPORTANT:** The cylinder head must be supported in a fashion that allows the machined head surface to be parallel to the arbor press bed and perpendicular to the press ram. This is necessary to permit the discharge valve stop to be installed squarely in its bore and to minimize the possibility of "cocking".

2. Install the discharge valve spring, discharge valve and valve seat. Using a 9/16" Allen wrench torque the discharge valve seat to 70-90 pound feet.

3. Test for leakage by the discharge valve. Apply 100 psi of air pressure through the cylinder head discharge port and apply a soap solution to the discharge valve and seat. A slight leakage in the form of soap bubbles is permissible. If excessive leakage is found, leave the air pressure applied and with the use of a fiber or hardwood dowel and a hammer, tap the discharge valve off its seat several times. This will help the valve to seat and should reduce the leakage. With the air pressure still applied at the discharge port of the cylinder head, check for leakage around the discharge valve stop exposed on the top of the cylinder head casting. No leakage is permitted.
4. If the unloader piston bushing was removed, press in a new bushing following the same pressing procedures given in Step 1. The inside diameter of the unloader piston bushing must be between .7497 inches and .7460 inches after pressing.
5. Using a 3/8" Allen wrench install the unloader piston stop and o-ring in the head. Torque to 175-225 pound inches.
6. Install the unloader piston and o-ring in the head so that the short stem of the piston rests on the unloader stop.
7. Install the unloader piston spring, small end first, on the stem of the unloader piston. Install the metal (copper) inlet valve gasket so that it rests on the shoulder of the inlet valve cavity. Install the inlet valve seat on top of the inlet valve gasket with its beveled side visible. Make certain the large coils of the piston spring rest within the recess of the inlet valve seat on the side opposite the bevel. Install the inlet valve so that it rests on the beveled side of the valve seat.
8. Install the inlet valve spring on the inlet valve stop and install the stop in the head. Using a spanner wrench, torque the inlet valve stop to between 70-90 pound feet.
9. Apply 100 psi air pressure to the unloader port of the governor mounting pad and note the inlet valve is driven away from its seat. Using a soap solution, test for air leakage at the unloader piston stop. No leakage is permitted.

### CRANKCASE & CRANKSHAFT ASSEMBLY

1. If the compressor requires a drive end crankshaft oil seal, press it into the crankcase until it is flush with the crankcase casting. Using clean oil lubricate the sealing lips of the seal.
2. If the compressor uses a ball type main bearing, press the ball bearing onto the correct end of the crankshaft. Position the ball bearing and the crankshaft in the crankcase, making sure the drive end of the crankshaft is positioned in the crankcase as marked before disassembly. **NOTE:** *In the case of compressors with a rear main ball bearing, make certain to install the thrust bearing in the crankcase before pressing the crankshaft*

and ball bearing into place. Carefully press the crankshaft and ball bearing into the crankcase using an arbor press. Make certain not to damage the oil seal, if the compressor is so equipped.

- Place the o-ring seal in the groove around the rear end cover or in the crankcase proper in the event a rear main ball bearing is in use. If the rear end cover contains a precision sleeve bearing that serves as the crankshaft main bearing, make certain to install the thrust bearing. Install the end cover in the position as marked before disassembly, taking care not to damage the sleeve bearing, if so equipped.
- Install the four cap screws or nuts that secure the rear end cover to the crankcase and torque to 175-225 pound inches.

### PISTON & CONNECTING ROD ASSEMBLY

- Prelubricate the piston, piston rings, wrist pin and connecting rod.
- Install the piston rings in the correct location with the ring pipemarks up. (Refer to Figure 11) Stagger the position of the ring gaps.
- Align the wrist pin bore of the connecting rod with the piston bores and install the wrist pin to secure the rod to the piston. Make certain the TEFLON "buttons" are installed in each end of the wrist pin.
- Using an automotive type ring compressor or similar tool, compress the piston rings and gently install the connecting rod and piston in the cylinder bore. Install the connecting rod cap on the connecting rod in the same position as marked during disassembly.
- Secure the rod cap to the rod using the two cap screws and special lockwashers. Torque the cap screw to between 120-140 pound inches and bend the tabs of the lockwashers until they are firmly against the flats of the hex head of the cap screws.

### BASE PLATE OR BASE ADAPTER ASSEMBLY

- Position the base plate or base adapter gasket on the crankcase and install the base plate or base adapter as marked before disassembly.
- Install the cap screws that secure either the crankcase base plate or crankcase mounting base adapter. Torque the cap screws evenly to the appropriate valve:

Base plate 85-115 pound inch mounting base adapter 175-225 pound inches.

### FINAL COMPRESSOR ASSEMBLY

- Place the cylinder head gasket on the crankcase and position the head on the crankcase as marked during disassembly. A gasket sealer is neither required or recommended.

- Secure the cylinder head to the crankcase using the four cylinder head cap screws. Torque the cap screws in a "X" pattern to between 175-225 pound inches.
- Using a thread sealant install all necessary pipe plugs and torque as follows:
  - 1/8" P.T. plugs - 85-105 pound inches
  - 1/2" P.T. plugs - 200-270 pound inches
- Install all crankshaft keys making certain to support the crankshaft to avoid bearing damage. Install the crankshaft nut where applicable. When installing drive couplings, gears or pulleys, DO NOT EXCEED 120 foot pounds torque on the crankshaft nut. The self locking crankshaft nut used on the BX-2150™ compressor requires that it be installed so that the narrow castellation slots are toward the end of the crankshaft and not against the pulley, coupling or gear that the nut retains.

Some BX-2150™ through drive compressors require the installation of a spline coupling on the rear of the crankshaft. The cap screw securing the coupling should be torqued to 175-225 inch pounds.

- Using covers, plugs, or masking tape to protect all ports if compressor is not to be installed immediately. Protect the ends of the crankshaft against damage by wrapping with masking tape or friction tape. The open bottom of a vertical engine lubricated compressors should be protected against the entrance of dirt during handling or storage, by installing a temporary cover over the base.

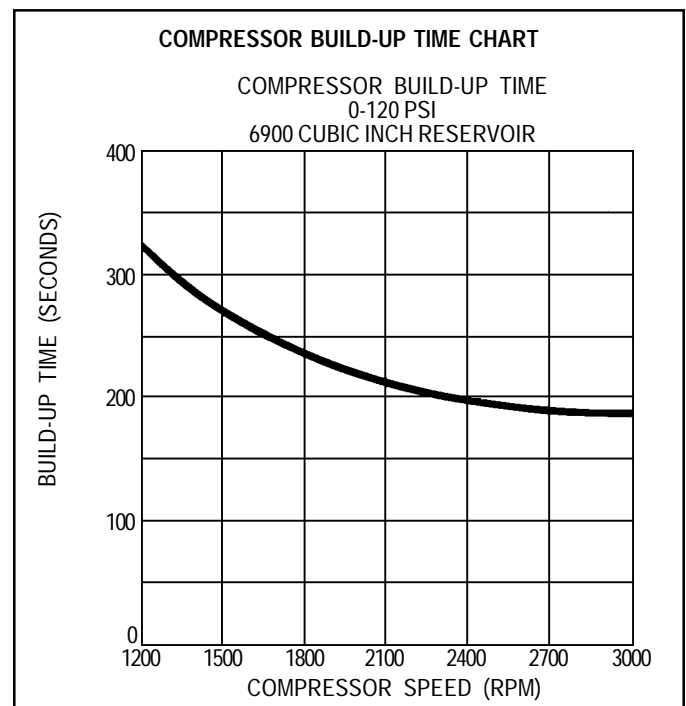

## TESTING REBUILT COMPRESSOR

In order to properly bench test a compressor under operating conditions, a test rack for correct mounting, cooling, lubricating, and driving the compressor is necessary. Such tests are not compulsory if the unit has been carefully rebuilt by an experienced person. A compressor efficiency or build-up test can be run which is not too difficult. The compressor must be connected to an oil supply line of at least 15 P.S.I. pressure during the test and an oil return line must be installed to keep the crankcase drained.

Connect the compressor discharge port to a reservoir with a volume of 650 cubic inches, including the volume of connecting line. With the compressor operating at 1800 R.P.M., the time required to raise the reservoir(s) pressure from 0 P.S.I. to 100 P.S.I. should not exceed 20 seconds. \*During this test, the compressor should be checked for gasket leakage and noisy operation, as well as unloader operation and leakage.

\*NOTE: With no inlet check valve or air strainer attached to the compressor inlet.

### TABULATED TECHNICAL DATA

Average weight	33 lbs.*
Number of cylinders	1
Bore size	3.375"
Stroke	1.468"
Displacement at 1250 R.P.M.	9.5 C.F.M.
Maximum recommended R.P.M.	3000 R.P.M.
Minimum coolant flow (water cooled) at	
Maximum R.P.M.	2.5 G.P.M.
Minimum R.P.M.	.5 G.P.M.
Minimum coolant flow (air-cooled)	N/A
Approximate horsepower required at	
1250 R.P.M. at 120 PSIG	
(naturally aspirated)	1.7
Turbocharge limits	
Maximum R.P.M.	2200 R.P.M.
Maximum pressure (gauge)	15 PSIG
Maximum inlet air temperature	250° F
Maximum discharge air temperature	400° F
Minimum pressure required to unload	
(naturally aspirated)	60 PSIG
(with inlet check valve)	85 PSIG
(turbocharged)	85 PSIG
Minimum oil pressure required	
at engine idling speed	5 PSIG
Minimum oil pressure required at	
any engine speed	15 PSIG
Oil capacity of self-lubricated model	N/A
Minimum discharge-line size	1/2" I.D.
Minimum coolant-line size	3/8" I.D.
Minimum oil-supply line size	3/16" I.D.
Minimum oil-return line size	1/2" I.D.
Minimum air-inlet line size	5/8" I.D.
Minimum unloader-line size	3/16" I.D.

\*Installed weight determined by final mounting configuration.

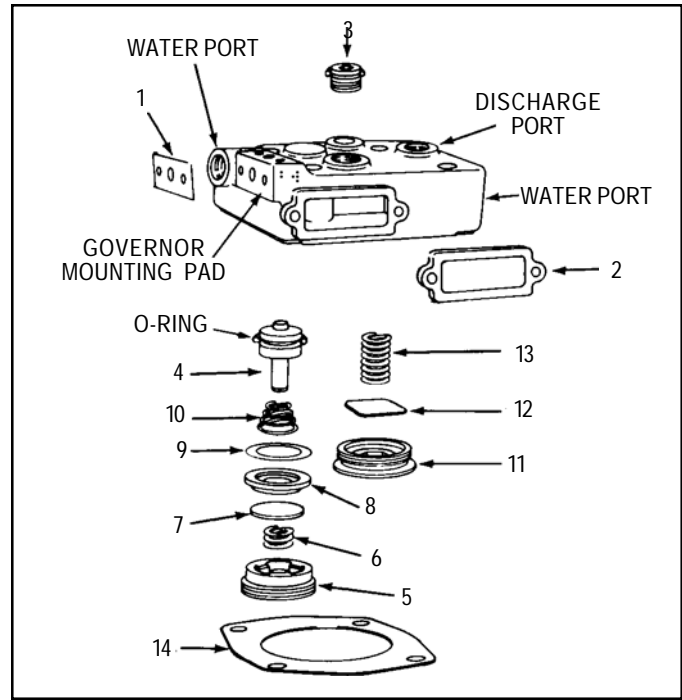

FIGURE 12

### UNLOADER KIT

The unloader kit is designed for use when unloader piston leakage is detected as described under the **Compressor Air Leakage Tests** section of this manual. The kit contains the following components which are keyed to Figure 12.

Qty.	Description	Key
1	Unloader stop assembly	3
1	Unloader piston assembly	4

### MAJOR MAINTENANCE KIT

The major maintenance kit is designed to rebuild the BX-2150™ compressor head assembly and contains the following parts which are keyed to Figure 12.

Qty.	Description	Key
1	Unloader Kit	3 & 4
1	Discharge Valve	12
1	Governor Gasket	1
1	Strainer Gasket	2
1	Discharge Valve Spring	13
1	Cylinder Head Gasket	14
1	Unloader Spring	10
1	Inlet Valve Gasket	9
1	Discharge Valve Seat	11
1	Inlet Valve Stop	5
1	Inlet Valve	7
1	Inlet Valve Seat	8
1	Inlet Valve Spring	6

This troubleshooting guide obsoletes and supersedes all previous published troubleshooting information relative to Bendix air compressors.

# Advanced Troubleshooting Guide for Air Brake Compressors\*

The guide consists of an introduction to air brake charging system components, a table showing recommended vehicle maintenance schedules, and a troubleshooting symptom and remedy section with tests to diagnose most charging system problems.

## INDEX

Symptom	Page Number	Symptom	Page Number
<b>Air</b>		<b>Coolant</b>	
Air brake charging system:		Compressor leaks coolant (17.0) . . . . .	27
Slow build (9.0) . . . . .	23 - 24	<b>Engine</b>	
Doesn't build air (10.0) . . . . .	25	Oil consumption (6.0) . . . . .	23
Air dryer:		<b>Oil</b>	
Doesn't purge (14.0) . . . . .	26	Oil Test Card results (1.0) . . . . .	18
Safety valve releases air (12.0) . . . . .	26	Oil is present:	
Compressor:		On the outside of the compressor (2.0) . . . . .	19
Constantly cycles (15.0) . . . . .	26	At the air dryer purge/exhaust	
Leaks air (16.0) . . . . .	27	or surrounding area (3.0) . . . . .	19
Safety valve releases air (11.0) . . . . .	25	In the supply reservoir (4.0) . . . . .	20 - 22
Noisy (18.0) . . . . .	27	At the valves (5.0) . . . . .	22
Reservoir:		At air dryer cartridge (7.0) . . . . .	23
Safety valve releases air (13.0) . . . . .	26	In the ping tank or compressor	
		discharge aftercooler (8.0) . . . . .	23

### Test Procedures

- (1) Oil Leakage at Head Gasket . . . . .28
- (2) System Leakage . . . . .28
- (3) Compressor Discharge and  
    Air Dryer Inlet Temperature . . . . .28
- (4) Governor Malfunction . . . . .29
- (5) Governor Control Line . . . . .29
- (6) Compressor Unloader . . . . .29
- BASIC Test Information . . . . . 30-32

### Maintenance & Usage Guidelines

- Maintenance Schedule and  
Usage Guidelines (Table A) . . . 17



\*This guide is only for vehicles that use desiccant air dryers.

# Introduction to the Air Brake Charging System

Powered by the vehicle engine, the **air compressor** builds the air pressure for the air brake system. The air compressor is typically cooled by the engine coolant system and lubricated by the engine oil supply.

The compressor's unloader mechanism and **governor** (along with a synchro valve for the Bendix® DuraFlo™ 596 air compressor) control the brake system air pressure between a preset maximum and minimum pressure level by monitoring the pressure in the service (or "supply") reservoir. When the air pressure becomes greater than that of the preset "cut-out", the governor controls the unloader mechanism of the compressor to stop the compressor from building air and also causes the air dryer to purge. As the service reservoir air pressure drops to the "cut-in" setting of the governor, the governor returns the compressor back to building air and the air dryer to air drying mode.

As the atmospheric air is compressed, all the water vapor originally in the air is carried along into the air system, as well as a small amount of the lubricating oil as vapor.

The **duty cycle** is the ratio of time the compressor spends building air to the total engine running time. Air compressors are designed to build air (run "loaded") up to 25% of the time. Higher duty cycles cause conditions that affect air brake charging system performance which may require additional maintenance. Factors that add to the duty cycle are: air suspension, additional air accessories, use of an undersized compressor, frequent stops, excessive leakage from fittings, connections, lines, chambers or valves, etc.

The **discharge line** allows the air, water-vapor and oil-vapor mixture to cool between the compressor and

air dryer. The typical size of a vehicle's discharge line, (see column 2 of Table A on page 17) assumes a compressor with a normal (less than 25%) duty cycle, operating in a temperate climate. See Bendix and/or other air dryer manufacturer guidelines as needed.

When the **temperature** of the compressed air that enters the air dryer is within the normal range, the air dryer can remove most of the charging system oil. If the temperature of the compressed air is above the normal range, oil as oil-vapor is able to pass through the air dryer and into the air system. Larger diameter discharge lines and/or longer discharge line lengths can help reduce the temperature.

The discharge line must maintain a **constant slope** down from the compressor to the air dryer inlet fitting to avoid low points where ice may form and block the flow. If, instead, ice blockages occur at the air dryer inlet, insulation may be added here, or if the inlet fitting is a typical 90 degree fitting, it may be changed to a straight or 45 degree fitting. For more information on how to help prevent discharge line freeze-ups, see Bendix Bulletins TCH-08-21 and TCH-08-22 (see pages 33-35). Shorter discharge line lengths or insulation may be required in cold climates.



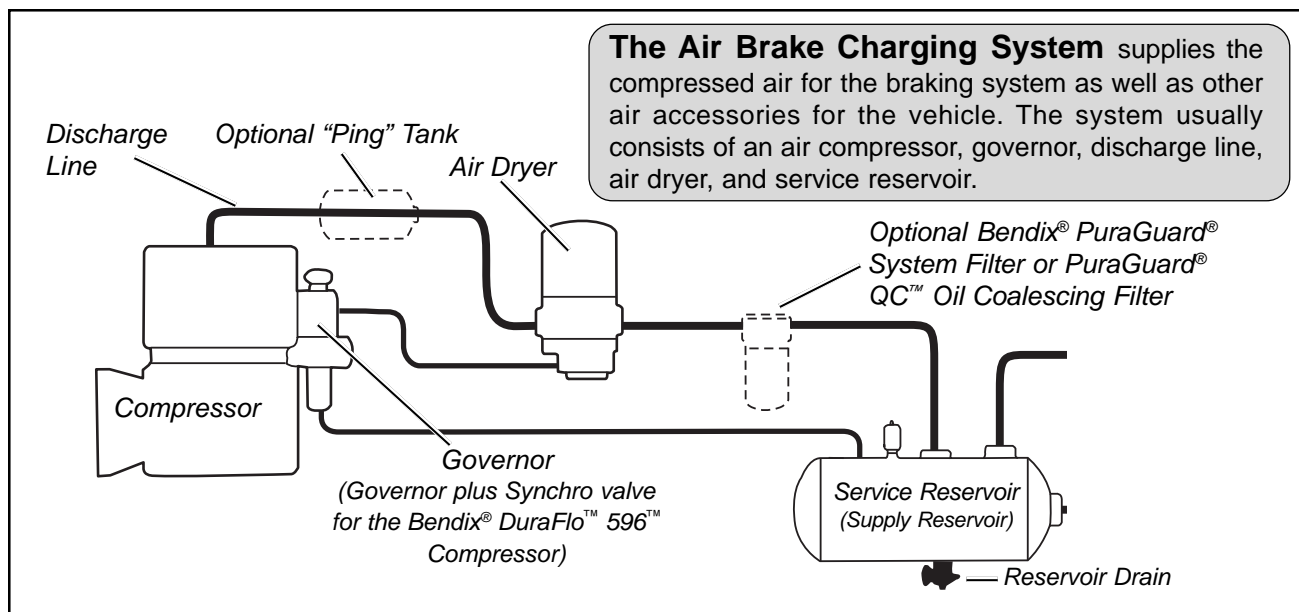

The **air dryer** contains a filter that collects oil droplets, and a desiccant bed that removes almost all of the remaining water vapor. The compressed air is then passed to the air brake service (supply) reservoir. The oil droplets and the water collected are automatically purged when the governor reaches its "cut-out" setting. For vehicles with accessories that are sensitive to small amounts of oil, we recommended installation of a Bendix® PuraGuard® system filter, designed to minimize the amount of oil present.





# Table A: Maintenance Schedule and Usage Guidelines

Regularly scheduled maintenance is the single most important factor in maintaining the air brake charging system.

Vehicle Used for:	No. of Axles	Column 1	Column 2		Column 3	Column 4	Column 5
		Typical Compressors Spec'd	Discharge Line		Recommended Air Dryer Cartridge Replacement <sup>1</sup>	Recommended Reservoir Drain Schedule <sup>2</sup>	Acceptable Reservoir Oil Contents <sup>3</sup> at Regular Drain Interval
			I.D.	Length			
<b>Low Air Use</b>							
<p>Compressor with less than 15% duty cycle</p> <p>e.g. Line haul single trailer w/o air suspension, air over hydraulic brakes.</p> 	5 or less	Bendix® BA-921™ air compressor	1/2 in.	6 ft.	Every 3 Years	Recommended Every Month - Max of every 90 days	BASIC test acceptable range: 3 oil units per month. See appendix A.
<p>Compressor with up to 25% duty cycle</p> <p>e.g. Line haul single trailer with air suspension, school bus.</p> 	5 or less		Bendix® Tu-Flo® 550 air compressor	1/2 in.			
<b>High Air Use</b>							
<p>Compressor with up to 25% duty cycle</p> <p>e.g. Double/triple trailer, open highway coach/RV, (most) pick-up &amp; delivery, yard or terminal jockey, off-highway, construction, loggers, concrete mixer, dump truck, fire truck.</p> 	8 or less	Bendix® Tu-Flo® 750 air compressor	1/2 in.	12 ft.	Every 2 Years	Every Month	BASIC test acceptable range: 5 oil units per month. See appendix A.
<p>Compressor with up to 25% duty cycle</p> <p>e.g. City transit bus, refuse, bulk unloaders, low boys, urban region coach, central tire inflation.</p> 	12 or less	Bendix® BA-922™, or DuraFlo™ 596 air compressor	5/8 in.	12 ft.			

For the BASIC Test Kit: Order Bendix P/N 5013711

**Footnotes:**

- 1 With increased air demand the air dryer cartridge needs to be replaced more often.
- 2 Use the drain valves to slowly drain all reservoirs to zero psi.
- 3 Allow the oil/water mixture to fully settle before measuring oil quantity.
- 4 To counter above normal temperatures at the air dryer inlet, (and resultant oil-vapor passing upstream in the air system) replace the discharge line with one of a larger diameter and/or longer length. This helps reduce the air's temperature. If sufficient cooling occurs, the oil-vapor condenses and can be removed by the air dryer. Discharge line upgrades are not covered under warranty. Note: To help prevent discharge line freeze-ups, shorter discharge line lengths or insulation may be required in cold climates. (See Bendix Bulletins TCH-08-21 and TCH-08-22, included in Appendix B, for more information.)
- 5 For certain vehicles/applications, where turbo-charged inlet air is used, a smaller size compressor may be permissible.

Note: Compressor and/or air dryer upgrades are recommended in cases where duty cycle is greater than the normal range (for the examples above).

For Bendix® Tu-Flo® 550 and 750 compressors, unloader service is recommended every 250,000 miles.

# Air Brake Charging System Troubleshooting

How to use this guide:

Find the **symptom(s)** that you see, then move to the right to find the possible causes ("**What it may indicate**") and remedies ("**What you should do**").

Review the warranty policy before performing any intrusive compressor maintenance. Unloader or cylinder head gasket replacement and resealing of the bottom cover plate are usually permitted under warranty. Follow all standard safety procedures when performing any maintenance.

Look for:

 **Normal**

Normal - Charging system is working within normal range.

 **Check**

Check - Charging system needs further investigation.

**WARNING! Please READ and follow these instructions to avoid personal injury or death:**

When working on or around a vehicle, the following general precautions should be observed at all times.

1. Park the vehicle on a level surface, apply the parking brakes, and always block the wheels. Always wear safety glasses.
2. Stop the engine and remove ignition key when working under or around the vehicle. When working in the engine compartment, the engine should be shut off and the ignition key should be removed. Where circumstances require that the engine be in operation, EXTREME CAUTION should be used to prevent personal injury resulting from contact with moving, rotating, leaking, heated or electrically charged components.
3. Do not attempt to install, remove, disassemble or assemble a component until you have read and thoroughly understand the recommended procedures. Use only the proper tools and observe all precautions pertaining to use of those tools.
4. If the work is being performed on the vehicle's air brake system, or any auxiliary pressurized air systems, make certain to drain the air pressure from all reservoirs before beginning ANY work on the vehicle. If the vehicle is equipped with an AD-IS™ air dryer system or a dryer reservoir module, be sure to drain the purge reservoir.

5. Following the vehicle manufacturer's recommended procedures, deactivate the electrical system in a manner that safely removes all electrical power from the vehicle.
6. Never exceed manufacturer's recommended pressures.
7. Never connect or disconnect a hose or line containing pressure; it may whip. Never remove a component or plug unless you are certain all system pressure has been depleted.
8. Use only genuine Bendix® replacement parts, components and kits. Replacement hardware, tubing, hose, fittings, etc. must be of equivalent size, type and strength as original equipment and be designed specifically for such applications and systems.
9. Components with stripped threads or damaged parts should be replaced rather than repaired. Do not attempt repairs requiring machining or welding unless specifically stated and approved by the vehicle and component manufacturer.
10. Prior to returning the vehicle to service, make certain all components and systems are restored to their proper operating condition.
11. For vehicles with Antilock Traction Control (ATC), the ATC function must be disabled (ATC indicator lamp should be ON) prior to performing any vehicle maintenance where one or more wheels on a drive axle are lifted off the ground and moving.

Symptom:	What it may indicate:	What you should do:
----------	-----------------------	---------------------

**1.0 Oil Test Card Results**

Not a valid test.

**Discontinue using this test.**

Do not use this card test to diagnose compressor "oil passing" issues. They are subjective and error prone. Use only the Bendix Air System Inspection Cup (BASIC) test and the methods described in this guide for advanced troubleshooting.

**The Bendix® BASIC test should be the definitive method for judging excessive oil fouling/oil passing.** (See Appendix A, on page 30 for a flowchart and expanded explanation of the checklist used when conducting the BASIC test.)

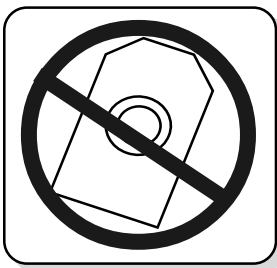

Bendix®  
BASIC Test



Symptom:	What it may indicate:	What you should do:
<b>2.0 Oil on the Outside of the Compressor</b>	Engine and/or other accessories leaking onto compressor.	Find the source and repair. Return the vehicle to service.
2.1 Oil leaking at compressor / engine connections:	(a) Leak at the front or rear (fuel pump, etc.) mounting flange.	⇒ Repair or replace as necessary. If the mounting bolt torques are low, replace the gasket.
	(b) Leak at air inlet fitting.	⇒ Replace the fitting gasket. Inspect inlet hose and replace as necessary.
	(c) Leak at air discharge fitting.	⇒ Replace gasket or fitting as necessary to ensure good seal.
	(d) Loose/broken oil line fittings.	⇒ Inspect and repair as necessary.
2.2 Oil leaking from compressor:	(a) Excessive leak at head gasket.	⇒ Go to Test 1 on page 28.
	(b) Leak at bottom cover plate.	⇒ Reseal bottom cover plate using RTV silicone sealant.
	(c) Leak at internal rear flange gasket.	⇒ Replace compressor.
	(d) Leak through crankcase.	⇒ Replace compressor.
	(e) (If unable to tell source of leak.)	⇒ Clean compressor and check periodically.

**? Check**

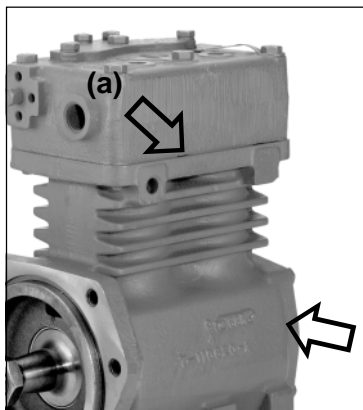

Head gasket and rear flange gasket locations.

<b>3.0 Oil at air dryer purge/exhaust or surrounding area</b>	Air brake charging system functioning normally.	<p><b>✓ Normal</b></p> <p>⇒ Air dryers remove water and oil from the air brake charging system. Check that regular maintenance is being performed. Return the vehicle to service. An optional kit (Bendix piece number 5011327 for the Bendix® AD-IS™ or AD-IP™ air dryers, or 5003838 for the Bendix® AD-9™ air dryer) is available to redirect the air dryer exhaust.</p>
---	---	---

**Symptom:****What it may indicate:****What you should do:****4.0 Oil in Supply or Service Reservoir (air dryer installed)**

(If a maintained Bendix® PuraGuard® system filter or Bendix® PuraGuard® QC™ oil coalescing filter is installed, call 1-800-AIR-BRAKE (1-800-247-2725) and speak to a Tech Team member.)



See Table A, on page 17, for maintenance schedule information.

**Maintenance**

- (a) **If air brake charging system maintenance has not been performed.**

That is, reservoir(s) **have not** been drained per the schedule in Table A on page 17, Column 4 **and/or** the air dryer maintenance **has not** been performed as in Column 3.

- (b) **If the vehicle maintenance has been performed** as recommended in Table A on page 17, some oil in the reservoirs is normal.



Drain all air tanks (reservoirs) into the Bendix® BASIC test cup. (Bendix kit P/N 5013711).

- ⇒ Drain all air tanks and check vehicle at next service interval using the Bendix® BASIC test. See Table A on page 17, column 3 and 4, for recommended service schedule.

**? Check**

- ⇒ Drain all air tanks into Bendix® BASIC test cup (Bendix Air System Inspection Cup). If less than one unit of reservoir contents is found, the vehicle can be returned to service. **Note: If more than one oil unit of water (or a cloudy emulsion mixture) is present, change the vehicle's air dryer, check for air system leakage (Test 2, on page 28), stop inspection and check again at the next service interval. See the BASIC test kit for full details.**

If less than one "oil unit" of water (or water/cloudy emulsion mixture) is present, use the BASIC cup chart on the label of the cup to determine if the amount of oil found is within the acceptable level.

- ⇒ If within the normal range, return the vehicle to service. For vehicles with accessories that are sensitive to small amounts of oil, consider a Bendix® PuraGuard® QC™ oil coalescing filter.

- ⇒ If outside the normal range go to Symptom 4.0(c).

Also see the Table A on page 17, column 3 for recommended air dryer cartridge replacement schedule.

**Duty cycle too high**

- (c) Air brake system leakage.

- ⇒ Go to Test 2 on page 28.

- (d) Compressor may be undersized for the application.

- ⇒ See Table A, column 1, on page 17 for recommended compressor sizes.

⇒ If the compressor is "too small" for the vehicle's role (for example, where a vehicle's use has changed or service conditions exceed the original vehicle or engine OE spec's) then upgrade the compressor. Note: The costs incurred (e.g. installing a larger capacity compressor, etc.) are not covered under original compressor warranty.

- ⇒ If the compressor is correct for the vehicle, go to Symptom 4.0 (e).

The **duty cycle** is the ratio of time the compressor spends building air to total engine running time. Air compressors are designed to build air (to "run loaded") up to 25% of the time. Higher duty cycles cause conditions that affect air brake charging system performance which may require additional maintenance. Factors that add to the duty cycle are: air suspension, additional air accessories, use of an undersized compressor, frequent stops, excessive leakage from fittings, connections, lines, chambers or valves, etc.

**Symptom:**

**What it may indicate:**

**What you should do:**

**4.0 Oil in Supply or Service Reservoir\* (air dryer installed) (continued)**

**Temperature**

- (e) Air compressor discharge and/or air dryer inlet temperature too high.
- (f) Insufficient coolant flow.



Testing the temperature at the discharge fitting.



Inspecting the coolant hoses.

- (g) Restricted discharge line.



Kinked discharge line shown.

⇒ Check temperature as outlined in Test 3 on page 28. If temperatures are normal go to 4.0(h).

⇒ Inspect coolant line. Replace as necessary (I.D. is 1/2").

⇒ Inspect the coolant lines for kinks and restrictions and fittings for restrictions. Replace as necessary.

⇒ Verify coolant lines go from engine block to compressor and back to the water pump. Repair as necessary.

⇒ If discharge line is restricted or more than 1/16" carbon build up is found, replace the discharge line. See Table A, column 2, on page 17 for recommended size. Replace as necessary.

⇒ The discharge line must maintain a **constant slope** down from the compressor to the air dryer inlet fitting to avoid low points where ice may form and block the flow. If, instead, ice blockages occur at the air dryer inlet, insulation may be added here, or if the inlet fitting is a typical 90 degree fitting, it may be changed to a straight or 45 degree fitting. For more information on how to help prevent discharge line freeze-ups, see Bendix Bulletins TCH-08-21 and TCH-08-22 (Appendix B). Shorter discharge line lengths or insulation may be required in cold climates.

**Other**

- (h) Restricted air inlet (not enough air to compressor).



Partly collapsed inlet line shown.

⇒ Check compressor air inlet line for restrictions, brittleness, soft or sagging hose conditions etc. Repair as necessary. Inlet line size is 3/4 ID. Maximum restriction requirement for compressors is 25 inches of water.

⇒ Check the engine air filter and service if necessary (if possible, check the air filter usage indicator).

**? Check**

\*If a maintained Bendix® PuraGuard® system filter or Bendix® PuraGuard® QC™ oil coalescing filter is installed, call 1-800-AIR-BRAKE (1-800-247-2725) and speak to a Tech Team member.

Symptom:	What it may indicate:	What you should do:
----------	-----------------------	---------------------

**4.0 Oil in Supply or Service Reservoir\* (air dryer installed) (continued)**

**Other (cont.)**

(i) Poorly filtered inlet air (poor air quality to compressor).



Inspect the engine air cleaner.

⇒ Check for leaking, damaged or defective compressor air inlet components (e.g. induction line, fittings, gaskets, filter bodies, etc.). Repair inlet components as needed. Note: Dirt ingestion will damage compressor and is not covered under warranty.

**? Check**

(j) Governor malfunction or setting.

⇒ Go to Test 4 on page 29.

(k) Compressor malfunction.

⇒ If you found excessive oil present in the service reservoir in step 4.0 (b) above and you did not find any issues in steps 4.0 (c) through 4.0 (j) above, the compressor may be passing oil. Replace compressor. If still under warranty, follow normal warranty process. Note: After replacing a compressor, residual oil may take a considerable period of time to be flushed from the air brake system.

**Crankcase Flooding**  
Consider installing a compressor bottom drain kit (where available) in cases of chronic oil passing where all other operating conditions have been investigated. Bendix compressors are designed to have a 'dry' sump and the presence of excess oil in the crankcase can lead to oil carryover.

\*If a maintained Bendix® PuraGuard® system filter or Bendix® PuraGuard® QC™ oil coalescing filter is installed, call 1-800-AIR-BRAKE (1-800-247-2725) and speak to a Tech Team member.

**5.0 Oil present at valves (e.g. at exhaust, or seen during servicing).**

Air brake system valves are required to tolerate a light coating of oil.

**✓ Normal**

⇒ A small amount of oil does not affect SAE J2024\*\* compliant valves.  
⇒ Check that regular maintenance is being performed and that the amount of oil in the air tanks (reservoirs) is within the acceptable range shown on the Bendix® BASIC test cup (see also column 5 of Table A on page 17). Return the vehicle to service.



Genuine Bendix valves are all SAE J2024 compliant.

For oil-sensitive systems, see page 16.

\*\* SAE J2024 outlines tests all air brake system pneumatic components need to be able to pass, including minimum levels of tolerance to contamination.

Symptom:	What it may indicate:	What you should do:
----------	-----------------------	---------------------

**6.0 Excessive oil consumption in engine.**

A problem with engine or other engine accessory.

⇒ See engine service manual.

**? Check**



The engine service manual has more information.

**7.0 Oil present at air dryer cartridge during maintenance.**

Air brake charging system is functioning normally.

**✓ Normal**

⇒ Air dryers remove water and oil from the air brake charging system. A small amount of oil is normal. Check that regular maintenance is being performed and that the amount of oil in the air tanks (reservoirs) is within the acceptable range shown by the BASIC Test (see also column 5 of Table A on page 17). Replace the air dryer cartridge as needed and return the vehicle to service.

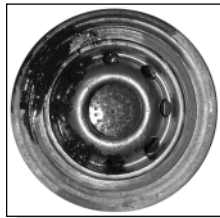

Oil shown leaking from an air dryer cartridge.

**8.0 Oil in ping tank or compressor discharge aftercooler.**

Air brake charging system is functioning normally.

⇒ Follow vehicle O.E. maintenance recommendation for these components.

**✓ Normal**

**9.0 Air brake charging system seems slow to build pressure.**

(a) Air brake charging system functioning normally.

⇒ Using dash gauges, verify that the compressor builds air system pressure from 85-100 psi in 40 seconds or less with engine at full governed rpm. Return the vehicle to service.

**✓ Normal**

(b) Air brake system leakage.

⇒ Go to Test 2 on page 28.

(c) Compressor may be undersized for the application.

⇒ See Table A, column 1, on page 17 for some typical compressor applications. If the compressor is "too small" for the vehicle's role, for example, where a vehicle's use has changed, then upgrade the compressor. Note: The costs incurred (e.g. installing a larger capacity compressor, etc.) are not covered under original compressor warranty.

(d) Compressor unloader mechanism malfunction.

⇒ Go to Test 6 on page 29.

(e) Damaged compressor head gasket.

⇒ An air leak at the head gasket may indicate a downstream restriction such as a freeze-up or carbon blockage and/or could indicate a defective or missing safety valve. Find blockage (go to 9.0(f) for details.) and then replace the compressor. Do not re-use the safety valve without testing. See Symptom 12.0(a).

**Symptom:**

**What it may indicate:**

**What you should do:**

**9.0 Air brake charging system seems slow to build pressure. (continued)**



Dash gauges.

(f) Restricted discharge line.

**? Check**



Kinked discharge line shown.

⇒ If discharge line is restricted:  
⇒ By more than 1/16" carbon build up, replace the discharge line (see Table A, column 2, on page 17 for recommended size) and go to Test 3 on page 28.  
⇒ By other restrictions (e.g. kinks). Replace the discharge line. See Table A, column 2, on page 17 for recommended size. Retest for air build. Return vehicle to service or, if problem persists, go to 9.0(a).

⇒ The discharge line must maintain a **constant slope** down from the compressor to the air dryer inlet fitting to avoid low points where ice may form and block the flow. If, instead, ice blockages occur at the air dryer inlet, insulation may be added here, or if the inlet fitting is a typical 90 degree fitting, it may be changed to a straight or 45 degree fitting. For more information on how to help prevent discharge line freeze-ups, see Bendix Bulletins TCH-08-21 and TCH-08-22 (Appendix B). Shorter discharge line lengths or insulation may be required in cold climates.

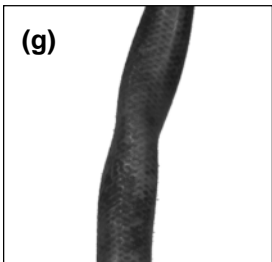

Partly collapsed inlet line shown.

(g) Restricted air inlet (not enough air to compressor).

**? Check**

⇒ Check compressor air inlet line for restrictions, brittleness, soft or sagging hose conditions etc. Repair as necessary. Refer to vehicle manufacturer's guidelines for inlet line size.

⇒ Check the engine air filter and service if necessary (if possible, check the air filter usage indicator).

(h) Poorly filtered inlet air (poor air quality to compressor).

**? Check**

⇒ Check for leaking, damaged or defective compressor air inlet components (e.g. induction line, fittings, gaskets, filter bodies, etc.). Repair inlet components as needed. Note: Dirt ingestion will damage compressor and is not covered under warranty.

(i) Compressor malfunction.

**? Check**

⇒ Replace the compressor only after making certain that none of the preceding conditions, 9.0 (a) through 9.0 (h), exist.



Symptom:	What it may indicate:	What you should do:
<b>10.0 Air charging system doesn't build air.</b>	(a) Governor malfunction*.	⇒ Go to Test 4 on page 29.
	(b) Restricted discharge line.	⇒ See 9.0(f).
	(c) Air dryer heater malfunction: exhaust port frozen open.	⇒ Replace air dryer heater.
	(d) Compressor malfunction.	⇒ Replace the compressor only after making certain the preceding conditions do not exist.

\* Note: For the Bendix® DuraFlo™ 596 air compressor, not only the governor, but also the SV-1™ synchro valve used would need to be tested. See Bulletin TCH-001-048.

**11.0 Compressor safety valve releases air (Compressor builds too much air).**

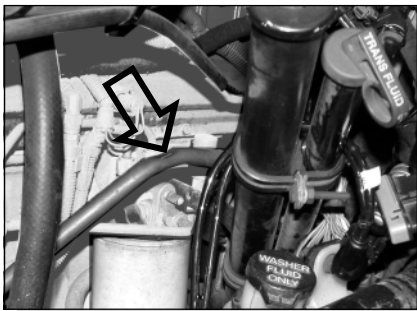



Damaged discharge line shown.

(a) Restricted discharge line.

**? Check**

- ⇒ If discharge line is restricted:
  - ⇒ By more than 1/16" carbon build up, replace the discharge line (see Table A, column 2, on page 17 for recommended size) and go to Test 3 on page 28.
  - ⇒ By other restrictions (e.g. kinks). Replace the discharge line. See Table A, column 2, on page 17 for recommended size.
- ⇒ The discharge line must maintain a **constant slope** down from the compressor to the air dryer inlet fitting to avoid low points where ice may form and block the flow. If, instead, ice blockages occur at the air dryer inlet, insulation may be added here, or if the inlet fitting is a typical 90 degree fitting, it may be changed to a straight or 45 degree fitting. For more information on how to help prevent discharge line freeze-ups, see Bendix Bulletins TCH-08-21 and TCH-08-22 (Appendix B). Shorter discharge line lengths or insulation may be required in cold climates.

- (b) Downstream air brake system check valves or lines may be blocked or damaged. ⇒ Inspect air lines and verify check valves are operating properly.
- (c) Air dryer lines incorrectly installed. ⇒ Ensure discharge line is installed into the inlet of the air dryer and delivery is routed to the service reservoir.
- (d) Compressor safety valve malfunction. ⇒ Verify relief pressure is 250 psi. Replace if defective.
- (e) Compressor unloader mechanism malfunction. ⇒ Go to Test 6 on page 29.
- (f) Governor malfunction. ⇒ Go to Test 4 on page 29.

Symptom:	What it may indicate:	What you should do:
<b>12.0 Air dryer safety valve releases air.</b>	<p>(a) Restriction between air dryer and reservoir.</p> <p>(b) Air dryer safety valve malfunction.</p> <p>(c) Air dryer maintenance not performed.</p> <p>(d) Air dryer malfunction.</p> <p>(e) Improper governor control line installation to the reservoir.</p> <p>(f) Governor malfunction.</p>	<p>⇒ Inspect delivery lines to reservoir for restrictions and repair as needed.</p> <p>⇒ Verify relief pressure is at vehicle or component manufacturer specifications. Replace if defective.</p> <p>⇒ See Maintenance Schedule and Usage Guidelines (Table A, column 3, on page 17).</p> <p>⇒ Verify operation of air dryer. Follow vehicle O.E. maintenance recommendations and component Service Data information.</p> <p>⇒ Go to Test 5 on page 29.</p> <p>⇒ Go to Test 4 on page 29.</p>
		
		
Technician removes governor.		
<b>13.0 Reservoir safety valve releases air</b>	<p>(a) Reservoir safety valve malfunction.</p> <p>(b) Governor malfunction.</p> <p>(c) Compressor unloader mechanism malfunction.</p>	<p>⇒ Verify relief pressure is at vehicle or component manufacturer's specifications (typically 150 psi). Replace if defective.</p> <p>⇒ Go to Test 4 on page 29.</p> <p>⇒ Go to Test 6 on page 29.</p>
<b>14.0 Air dryer doesn't purge. (Never hear exhaust from air dryer.)</b>	<p>(a) Air dryer malfunction.</p> <p>(b) Governor malfunction.</p> <p>(c) Air brake system leakage.</p> <p>(d) Improper governor control line installation to the reservoir.</p>	<p>⇒ Verify operation of air dryer. Follow vehicle O.E. maintenance recommendations.</p> <p>⇒ Go to Test 4 on page 29.</p> <p>⇒ Go to Test 2 on page 28.</p> <p>⇒ Go to Test 5 on page 29.</p>
<b>15.0 Compressor constantly cycles (compressor remains unloaded for a very short time.)</b>	<p>(a) Air brake charging system maintenance not performed.</p> <p style="text-align: center;"><b>? Check</b></p> <p>(b) Compressor unloader mechanism malfunction.</p> <p>(c) Air dryer purge valve or delivery check valve malfunction.</p> <p>(d) Air brake system leakage.</p>	<p>⇒ Available reservoir capacity may be reduced by build up of water etc. Drain and perform routine maintenance per Table A, columns 3 &amp; 4, on page 17.</p> <p>⇒ Go to Test 6 on page 29.</p> <p>⇒ Verify operation of air dryer. Follow vehicle O.E. maintenance recommendations and component Service Data information.</p> <p>⇒ Go to Test 2 on page 28.</p>

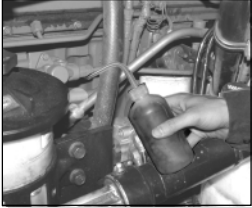
Symptom:	What it may indicate:	What you should do:
<b>16.0 Compressor leaks air</b>   Testing for leaks with soap solution.	(a) Compressor leaks air at connections or ports.	⇒ Check for leaking, damaged or defective compressor fittings, gaskets, etc. Repair or replace as necessary.
	(b) Compressor unloader mechanism malfunction.	⇒ Go to Test 6 on page 29.
	(c) Damaged compressor head gasket.	⇒ An air leak at the head gasket may indicate a downstream restriction such as a freeze-up or carbon blockage and/or could indicate a defective or missing safety valve. Find blockage (go to 9.0(f) for details.) and then replace the compressor. Do not re-use the safety valve without testing. See Symptom 12.0(a).
<b>17.0 Compressor leaks coolant</b>	(a) Improperly installed plugs or coolant line fittings.	⇒ Inspect for loose or over-torqued fittings. Reseal and tighten loose fittings and plugs as necessary. If overtorqued fittings and plugs have cracked ports in the head, replace the compressor.
	(b) Damaged compressor head gasket.	⇒ An air leak at the head gasket may indicate a downstream restriction such as a freeze-up or carbon blockage and/or could indicate a defective or missing safety valve. Find blockage (go to 9.0(f) for details.) and then replace the compressor. Do not re-use the safety valve without testing. See Symptom 12.0(a).
	(c) Porous compressor head casting.	⇒ If casting porosity is detected, replace the compressor.
<b>18.0 Noisy compressor (Multi-cylinder compressors only)</b>	(a) Damaged compressor.	⇒ Replace the compressor.

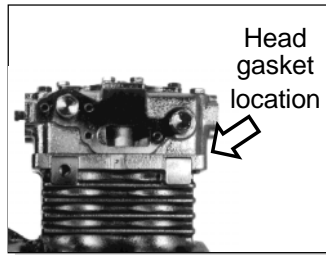

#### Other Miscellaneous Areas to Consider

This guide attempts to cover most compressor system problems. Here are some rare sources of problems not covered in this guide:

- Turbocharger leakage. Lubricating oil from leaking turbocharger seals can enter the air compressor intake and give misleading symptoms.

- Where a compressor does not have a safety valve installed, if a partial or complete discharge line blockage has occurred, damage can occur to the connecting rod bearings. Damage of this kind may not be detected and could lead to compressor problems at a later date.

# Tests

## Test 1: Excessive Oil Leakage at the Head Gasket

Exterior leaks at the head gasket are not a sign that oil is being passed into the air charging system. Oil weepage at the head gasket does not prevent the compressor from building air.

Observe the amount of weepage from the head gasket.

If the oil is only around the cylinder head area, it is acceptable (return the vehicle to service), but, if the oil weepage extends down to the nameplate area of the compressor, the gasket can be replaced.

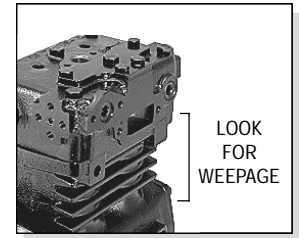

## Test 2: Air Brake System and Accessory Leakage

Inspect for air leaks when working on a vehicle and repair them promptly.

Park the vehicle on level ground and chock wheels. Build system pressure to governor cut-out and allow the pressure to stabilize for one minute.

**Step 1:** Observe the dash gauges for two additional minutes without the service brakes applied.

**Step 2:** Apply the service brakes and allow the pressure to stabilize. Continue holding for two minutes (you may use a block of wood to hold the

pedal in position.) Observe the dash gauges.

If you see **any noticeable decrease** of the dash air gauge readings (i.e. more than 4 psi, plus two psi for each additional trailer) during either two minute test, **repair the leaks** and repeat this test to confirm that they have been repaired.

Air leaks can also be found in the charging system, parking brakes, and/or other components - inspect and repair as necessary.

## Test 3: Air Compressor Discharge Temperature and Air Dryer Inlet Temperature\*

**Caution:** The temperatures used in this test are not normal vehicle conditions.

**Above normal temperatures can cause oil (as vapor) to pass through the air dryer into the air brake system.**

This test is run with the engine at normal operating temperature, with engine at max. rpm. If available, a dyno may be used.

1. Allow the compressor to build the air system pressure to governor cut-in.
2. Pump the brakes to bring the dash gauge pressure to 90 psi.
3. Allow the compressor to build pressure from 95 to 105 psi gauge pressure and maintain this pressure range by cycling the brakes for **five (5) minutes**.

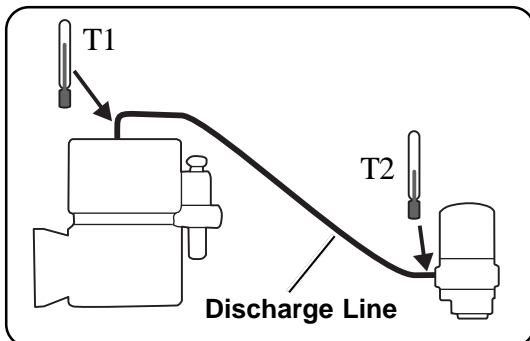

(\* Note that only vehicles that have passed Test 2 would be candidates for this test.)

4. Then, while maintaining max rpm and pressure range, measure and **record the surface temperature** of the **ittings**:
  - ⇒ at the compressor discharge port. (T1).
  - ⇒ at the air dryer inlet fitting. (T2).
 Use a touch probe thermocouple for measuring the temperature.
5. See table below.
6. Retest before returning the vehicle to service.

T1 Compressor Discharge Fitting	T2 Air Dryer Inlet Fitting	Action
under 360°F	under 200°F	Temperatures are within normal range for this test, check other symptoms. Go to 4.0 (h).
under 360°F	over 200°F	This could indicate a discharge line problem (e.g. restriction). Call 1-800-AIR-BRAKE (1-800-247-2725) and speak with our Tech Team.
over 360°F	—	Compressor is running hot. Check coolant 4(f) and/or discharge line 4(g).

## Tests (continued)

### Test 4: Governor Malfunction

1. Inspect control lines to and from the governor for restrictions (e.g. collapsed or kinked). Repair as necessary.
2. Using a calibrated external gauge in the supply

reservoir, service reservoir, or reservoir port of the D-2™ governor, verify cut-in and cut-out pressures are within vehicle OEM specification.

3. If the governor is malfunctioning, replace it.

### Test 5: Governor Control Line

1. Ensure that the governor control line from the reservoir is located at or near the top of the reservoir. (This line, if located near the bottom of the reservoir, can become blocked or restricted by the reservoir contents e.g. water or ice.)

2. Perform proper reservoir drain intervals and air dryer cartridge maintenance per Maintenance Schedule and Usage Guidelines (Table A on page 17).
3. Return the vehicle to service.

### Test 6: Compressor Unloader Leakage

**Bendix® Compressors:** Park vehicle, chock wheels, and follow all standard safety procedures. Remove the governor and install a fitting to the unloader port. Add a section of air hose (min 1ft long for a 1/2" diameter line) and a gauge to the fitting followed by a shut-off valve and an air source (shop air or small air tank). Open the shut

off and charge the unloader port by allowing air pressure to enter the hose and unload the compressor. Shut off the air supply and observe the gauge. A steady reading indicates no leakage at the unloader port, but a falling reading shows that the unloader mechanism is leaking and needs to be serviced.

## Appendix A: Information about the BASIC Test Kit (Bendix P/N 5013711)

### Bendix® Air System Inspection Cup (BASIC) Test Information

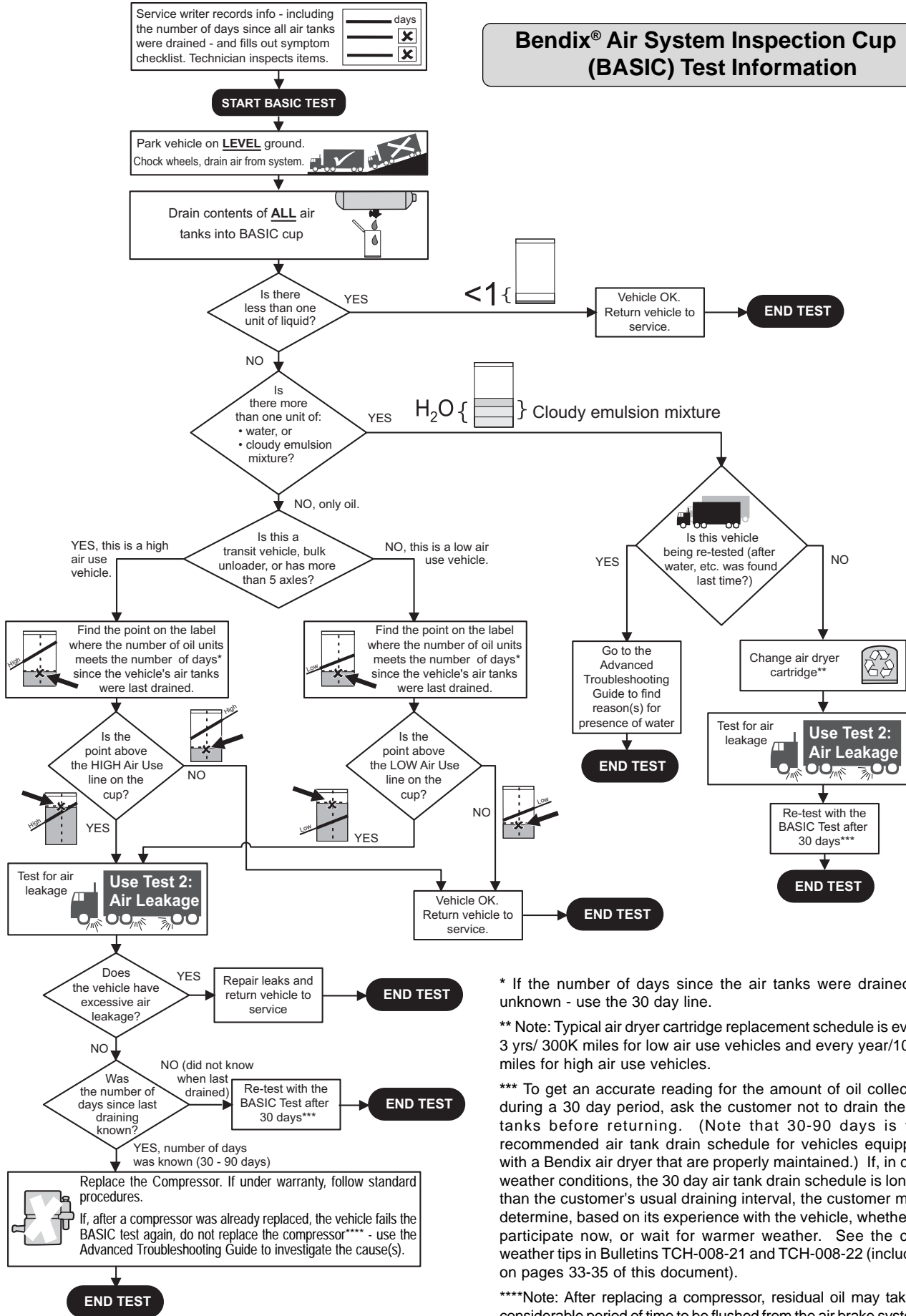

\* If the number of days since the air tanks were drained is unknown - use the 30 day line.

\*\* Note: Typical air dryer cartridge replacement schedule is every 3 yrs/ 300K miles for low air use vehicles and every year/100K miles for high air use vehicles.

\*\*\* To get an accurate reading for the amount of oil collected during a 30 day period, ask the customer not to drain the air tanks before returning. (Note that 30-90 days is the recommended air tank drain schedule for vehicles equipped with a Bendix air dryer that are properly maintained.) If, in cold weather conditions, the 30 day air tank drain schedule is longer than the customer's usual draining interval, the customer must determine, based on its experience with the vehicle, whether to participate now, or wait for warmer weather. See the cold weather tips in Bulletins TCH-008-21 and TCH-008-22 (included on pages 33-35 of this document).

\*\*\*\*Note: After replacing a compressor, residual oil may take a considerable period of time to be flushed from the air brake system.

Appendix A continued: Information about the BASIC Test Kit (Bendix P/N 5013711)

Filling in the Checklist for the Bendix® Air System Inspection Cup (BASIC) Test

Note: Follow all standard safety precautions. For vehicles using a desiccant air dryer.

The Service Writer fills out these fields with information gained from the customer

Number of Days Since Air Tanks Were Last Drained: \_\_\_\_\_ Date: \_\_\_\_\_ Vehicle #: \_\_\_\_\_  
 Engine SN \_\_\_\_\_ Vehicle Used for: \_\_\_\_\_ Typical Load: \_\_\_\_\_ (lbs.)  
 No. of Axles: \_\_\_\_ (tractor) \_\_\_\_ (trailer) No. of Lift Axles: \_\_\_\_ Technician's Name: \_\_\_\_\_

Customer's Complaint (Please check all that apply)	Checklist for Technician Have you confirmed complaint?
"Relay valve <input type="checkbox"/> leaks oil / <input type="checkbox"/> malfunctions" . . . . .	<input type="checkbox"/> no <input type="checkbox"/> yes*
"Dash valve <input type="checkbox"/> leaks oil / <input type="checkbox"/> malfunctions" . . . . .	<input type="checkbox"/> no <input type="checkbox"/> yes*
<input type="checkbox"/> "Air dryer leaks oil" . . . . .	<input type="checkbox"/> no <input type="checkbox"/> yes*
<input type="checkbox"/> "Governor malfunction" . . . . .	<input type="checkbox"/> no <input type="checkbox"/> yes*
<input type="checkbox"/> "Oil in gladhands" . . . . .	<input type="checkbox"/> no <input type="checkbox"/> yes*
how much oil did you find? _____	
<input type="checkbox"/> "Oil on ground or vehicle exterior" . . . . .	<input type="checkbox"/> no <input type="checkbox"/> yes*
amount described: _____	
<input type="checkbox"/> "Short air dryer cartridge life" replaces every: _____ <input type="checkbox"/> miles, <input type="checkbox"/> kms, or <input type="checkbox"/> months	
<input type="checkbox"/> "Oil in air tanks" amount described: _____	
We will measure amount currently found when we get to step B of the test.	
<input type="checkbox"/> "Excessive engine oil loss" amount described: _____	
Is the engine leaking oil? . . . . .	<input type="checkbox"/> no <input type="checkbox"/> yes*
Is the compressor leaking oil? . . . . .	<input type="checkbox"/> no <input type="checkbox"/> yes*
<input type="checkbox"/> Other complaint: _____	
<input type="checkbox"/> No customer complaint.	

The Service Writer also checks off any complaints that the customer makes to help the Technician in investigating.

The Technician checks boxes for any of the complaints that can be confirmed.

\* Note: A confirmed complaint above **does NOT** mean that the compressor must be replaced. The full BASIC test below will investigate the facts.

**BASIC test starts here:**

**STEP A - Select one:**

- This is a low air use vehicle: Line haul (single trailer) with 5 or less axles, or
  - This is a high air use vehicle: Garbage truck, transit bus, bulk unloader, or line haul with 6 or more axles.
- Then go to Step B.**

The Technician selects the air use category for the vehicle. This decided which of the two acceptance lines on the cup will be used for the test below.

**STEP B - Measure the Charging System Contents**

1. Park and chock vehicle on level ground. Drain the air system by pumping the service brakes.
2. Completely drain ALL the air tanks into a single BASIC cup.
3. If there is less than one unit of contents total, end the test now and return the vehicle to service. Vehicle passes.
4. **If more than one oil unit of water (or a cloudy emulsion mixture) is found:**
  - (a) Change the vehicle's air dryer cartridge - see Footnote 1,
  - (b) Conduct the 4 minute leakage test (Step D),
  - (c) **STOP the inspection, and check the vehicle again after 30 days** - see Footnote 2.



**Note for returning vehicles that are being retested after a water/cloudy emulsion mixture was found last time and the air dryer cartridge replaced: If more than one oil unit of water or a cloudy emulsion mixture is found again, stop the BASIC test and consult the air dryer's Service Data sheet troubleshooting section.**

For an accurate test, the contents of all the air tanks on the vehicle should be used.

**Otherwise, go to Step C.**



**Footnote 1:** Note: Typical air dryer cartridge replacement schedule is every 3 yrs/ 300K miles for low air use vehicles and every year/100K miles for high air use vehicles.

**Footnote 2:** To get an accurate reading for the amount of oil collected during a 30 day period, ask the customer not to drain the air tanks before returning. (Note that 30-90 days is the recommended air tank drain schedule for vehicles equipped with a Bendix air dryer that are properly maintained.) If, in cold weather conditions, the 30 day air tank drain schedule is longer than the customer's usual draining interval, the customer must determine, based on its experience with the vehicle, whether to participate now, or wait for warmer weather. See the cold weather tips in Bulletins TCH-008-21 and TCH-008-22 (included in Appendix B of the advanced troubleshooting guide).

Appendix A continued: Information about the BASIC Test Kit (Bendix P/N 5013711)

Filling in the Checklist for the Bendix® Air System Inspection Cup (BASIC) Test

Note: Follow all standard safety precautions. For vehicles using a desiccant air dryer.

**STEP C - How to Use the BASIC Test**

The Technician uses the chart (label) on the BASIC test cup to help decide the action to take, based on the amount of oil found. Use the lower acceptance line for low air use vehicles, and upper line for high air use vehicles (from Step A).

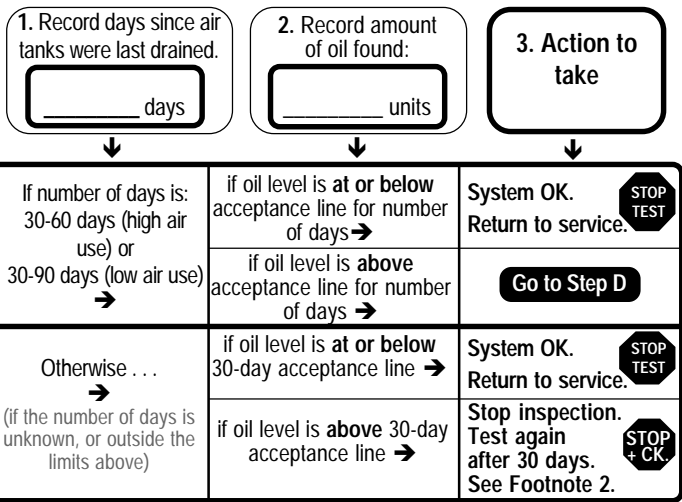

**BASIC Test Example**

An oil level of 4 units in a sixty-day period is within the acceptance area (at or below the line) for both low and high air use vehicles. Return the vehicle to service.

The Technician looks for the point where the number of days since the air tanks were drained meets the oil level. If it is at or below the (low or high use) acceptance line, the vehicle has passed the test. If the point is above the line we go to the leakage test.

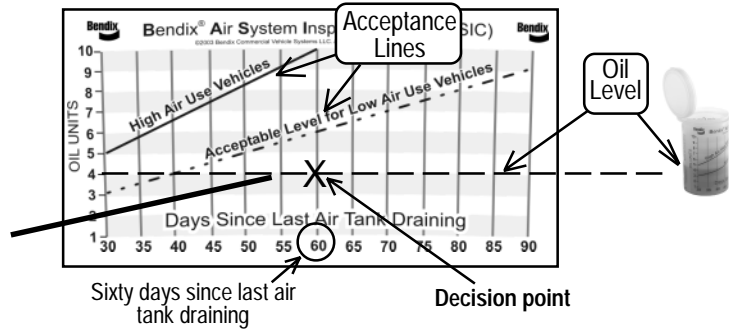

Air leakage is the number one cause of compressors having to pump excessive amounts of air, in turn run too hot and pass oil vapor along into the system. Here the Technician conducts a four-minute test to see if leakage is a problem with the vehicle being tested.

**STEP D - Air Brake System Leakage Test**

Park the vehicle on level ground and chock wheels. Build system pressure to governor cut-out and allow the pressure to stabilize for one minute.

- 1: Observe the dash gauges for two additional minutes without the service brakes applied.
- 2: Apply service brakes for two minutes (allow pressure to stabilize) and observe the dash gauges.

If you see any noticeable decrease of the dash air gauge readings repair leaks. Repeat this test to confirm that air leaks have been repaired and return vehicle to service. Please repeat BASIC test at next service interval. Note: Air leaks can also be found in the charging system, parking brakes, and/or other components - inspect and repair as necessary.

**If no air leakage was detected, and if you are conducting this test after completing Step C, go to Step E.**

**STEP E - If no air leakage was detected in Step D**

Replace the compressor.

Note: If the compressor is within warranty period, please follow standard warranty procedures. Attach the completed checklist to warranty claim.

The Technician only reaches Step E if the amount of oil found, for the amount of time since the air tanks were last drained exceeds the acceptance level, AND the vehicle passes the four-minute leakage test (no noticeable leakage was detected).



# Technical Bulletin



Bulletin No.: TCH-008-021

Effective Date: 11/1/92

Page: 1 of 2

## Subject: Air Brake System - Cold Weather Operation Tips

As the cold weather approaches, operators and fleets alike begin to look to their vehicles with an eye toward “winterization”, and particularly what can be done to guard against air system freeze-up. Here are some basic “Tips” for operation in the cold weather.

### Engine Idling

**Avoid idling the engine for long periods of time!** In addition to the fact that most engine manufacturers warn that long idle times are detrimental to engine life, winter idling is a big factor in compressor discharge line freeze-up. Discharge line freeze-ups account for a significant number of compressor failures each year. The discharge line recommendations under “Discharge Lines” are important for all vehicles but are especially so when some periods of extended engine idling can not be avoided.

### Discharge Lines

The discharge line should slope downward from the compressor discharge port without forming water traps, kinks, or restrictions. Cross-overs from one side of the frame rail to the other, if required, should occur as close as possible to the compressor. Fitting extensions must be avoided. Recommended discharge line lengths and inside diameters are dependent on the vehicle application and are as follows.

### **Typical P&D, School Bus and Line Haul**

The maximum discharge line length is 16 feet.

<u>Length</u>	<u>I.D. Min.</u>	<u>Other Requirements</u>
6.0-9.5 ft.	½ in.	None
9.5-12 ft.	½ in.	Last 3 feet, including fitting at the end of the discharge line, must be insulated with ½ inch thick closed cell polyethylene pipe insulation.
12-16 ft.	5/8 in.	Last 3 feet, including fitting at the end of the discharge line, must be insulated with ½ inch thick closed cell polyethylene pipe insulation.

If the discharge line length must be less than 6 feet or greater than 16 feet, contact your local Bendix representative.

**High Duty Cycle Vehicles (City Transit Coaches, Refuse Haulers, Etc.)**

The maximum discharge line length is 16 feet.

<u>Length</u>	<u>I.D. min.</u>	<u>Other Requirements</u>
10-16 ft.	½ in.	None

If the discharge line length must be less than 10 feet or greater than 16 feet, contact your local Bendix representative.

**System Leakage**

Check the air brake system for excessive air leakage using the Bendix "Dual System Air Brake Test and Check List" (BW1279). Excessive system leakage causes the compressor to "pump" more air and also more moisture into the brake system.

**Reservoir Draining (System Without Air Dryer)**

Routine reservoir draining is the most basic step (although not completely effective) in reducing the possibility of freeze-up. **All reservoirs** in a brake system can accumulate water and other contamination and must be drained! The best practice is to drain all reservoirs daily. When draining reservoirs; turn the ENGINE OFF and drain ALL AIR from the reservoir, better still, open the drain cocks on all reservoirs and leave them open over night to assure all contamination is drained (reference Service Data Sheet SD-04-400 for Bendix Reservoirs). If automatic drain valves are installed, check their operation **before** the weather turns cold (reference Service Data Sheet SD-03-2501 for Bendix® DV-2™ Automatic Drain Valves). It should be noted that, while the need for daily reservoir draining is eliminated through the use of an automatic drain valve, periodic manual draining is still required.

**Alcohol Evaporator or Injector Systems**

Check for proper operation of these systems by monitoring alcohol consumption for a few days (Reference Service Data Sheet SD-08-2301 for the Bendix Alcohol Evaporator). Too little means the system is not receiving adequate protection and too much simply wastes alcohol. As a general guide, these systems should consume approximately 1 to 2 ounces of alcohol per hour of compressor loaded time (compressing air). City pick-up and delivery vehicles will operate with the compressors loaded (compressing air) more while compressors on highway vehicles will be loaded less. These figures are approximate and assume that air system leakage is within the limits of the Bendix "Dual System Air Brake Test and Check List" (BW1279). Last but not least, begin using alcohol several weeks prior to freezing weather to ensure that the system is completely protected. Use only methanol alcohol, such as Bendix "Air Guard", in evaporators or injectors.

**Air Dryers**

Make certain air brake system leakage is within the limits stated in BW1279. Check the operation and function of the air dryer using the appropriate Service Data Sheet for the air dryer.

AD-9™ Air Dryer	Service Data Sheet SD-08-2412
AD-4™ Air Dryer	Service Data Sheet SD-08-2407
AD-2™ Air Dryer	Service Data Sheet SD-08-2403
AD-IP™ Air Dryer	Service Data Sheet SD-08-2414
AD-SP™ Air Dryer	Service Data Sheet SD-08-2415
Trailer System-Guard™ Air Dryer	Service Data Sheet SD-08-2416



# Technical Bulletin

Bulletin No.: TCH-008-022

Effective Date: 1/1/1994

Page: 1 of 1

## Subject: **Additional Cold Weather Operation Tips for the Air Brake System**

Last year we published Bulletin PRO-08-21 which provided some guidelines for "winterizing" a vehicle air brake system. Here are some additional suggestions for making cold weather vehicle operation just a little more bearable.

### **Thawing Frozen Air Lines**

The old saying; "Prevention is the best medicine" truly applies here! Each year this activity accounts for an untold amount of unnecessary labor and component replacement. Here are some Do's and Don'ts for prevention and thawing.

#### **Do's**

1. Do maintain freeze prevention devices to prevent road calls. Don't let evaporators or injectors run out of methanol alcohol or protection will be degraded. Check the air dryer for proper operation and change the desiccant when needed.
2. Do thaw out frozen air lines and valves by placing the vehicle in a warmed building. This is the only method for thawing that will not cause damage to the air system or its components.
3. Do use dummy hose couplings on the tractor and trailer.
4. Do check for sections of air line that could form water traps. Look for "drooping" lines.

#### **Don'ts**

1. Do not apply an open flame to air lines and valves. Beyond causing damage to the internal nonmetallic parts of valves and melting or burning non-metallic air lines. **WARNING: THIS PRACTICE IS UNSAFE AND CAN RESULT IN VEHICLE FIRE!**
2. Do not introduce (pour) fluids into air brake lines or hose couplings ("glad hands"). Some fluids used can cause immediate and severe damage to rubber components. Even methanol alcohol, which is used in Alcohol Evaporators and Injectors, should not be poured into air lines. Fluids poured into the system wash lubricants out of valves, collect in brake chambers and valves and can cause malfunction. Loss of lubricant can affect valve operating characteristics, accelerate wear and cause premature replacement.
3. Do not park a vehicle outside after thawing its air system indoors. Condensation will form in the system and freeze again. Place the vehicle in operation when it is removed to the outdoors.

### **Supporting Air and Electrical Lines**

Make certain tie wraps are replaced and support brackets are re-assembled if removed during routine maintenance. These items prevent the weight of ice and snow accumulations from breaking or disconnecting air lines and wires.

### **Automatic Drain Valves (System without Air Dryer)**

As we stated last year, routine reservoir draining is the most basic step (although not completely effective) in reducing the possibility of freeze-up. While automatic drain valves relieve the operator of draining reservoirs on a daily basis, these valves **MUST** be routinely checked for proper operation. Don't overlook them until they fail and a road call is required.

