



Service Data

SD-03-4020

Bendix® SV-1™ Synchro Valve SV-3™ & SV-4™ Trailer Release Valve

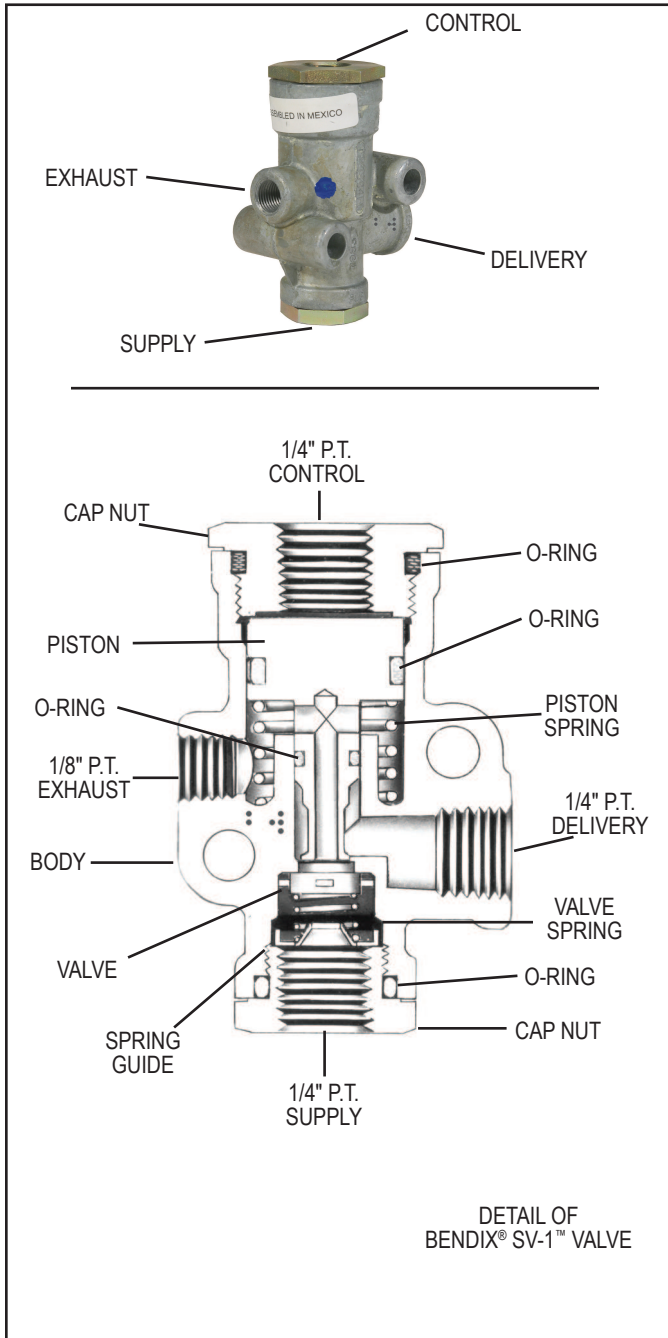

FIGURE 1 - BENDIX® SV-1™ SYNCHRO VALVE

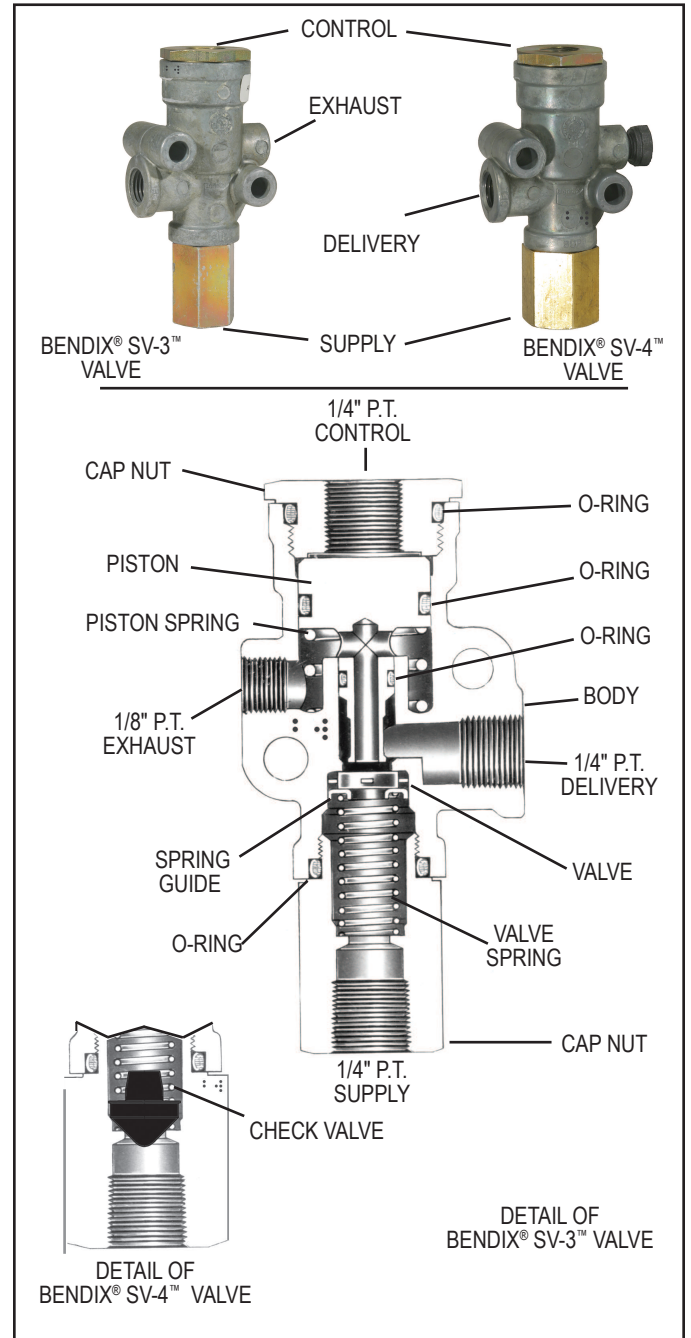

FIGURE 2 - BENDIX® SV-3™ & SV-4™ TRAILER RELEASE VALVE



**GENERAL SAFETY GUIDELINES
WARNING! PLEASE READ AND
FOLLOW THESE INSTRUCTIONS
TO AVOID PERSONAL INJURY OR DEATH:**

When working on or around a vehicle, the following guidelines should be observed AT ALL TIMES:

- ▲ Park the vehicle on a level surface, apply the parking brakes and always block the wheels. Always wear personal protection equipment.
- ▲ Stop the engine and remove the ignition key when working under or around the vehicle. When working in the engine compartment, the engine should be shut off and the ignition key should be removed. Where circumstances require that the engine be in operation, **EXTREME CAUTION** should be used to prevent personal injury resulting from contact with moving, rotating, leaking, heated or electrically-charged components.
- ▲ Do not attempt to install, remove, disassemble or assemble a component until you have read, and thoroughly understand, the recommended procedures. Use only the proper tools and observe all precautions pertaining to use of those tools.
- ▲ If the work is being performed on the vehicle's air brake system, or any auxiliary pressurized air systems, make certain to drain the air pressure from all reservoirs before beginning ANY work on the vehicle. If the vehicle is equipped with a Bendix® AD-IS® air dryer system, a Bendix® DRM™ dryer reservoir module, or a Bendix® AD-9si™ air dryer, be sure to drain the purge reservoir.
- ▲ Following the vehicle manufacturer's recommended procedures, deactivate the electrical system in a manner that safely removes all electrical power from the vehicle.
- ▲ Never exceed manufacturer's recommended pressures.
- ▲ Never connect or disconnect a hose or line containing pressure; it may whip. Never remove a component or plug unless you are certain all system pressure has been depleted.
- ▲ Use only genuine Bendix® brand replacement parts, components and kits. Replacement hardware, tubing, hose, fittings, etc. must be of equivalent size, type and strength as original equipment and be designed specifically for such applications and systems.
- ▲ Components with stripped threads or damaged parts should be replaced rather than repaired. Do not attempt repairs requiring machining or welding unless specifically stated and approved by the vehicle and component manufacturer.
- ▲ Prior to returning the vehicle to service, make certain all components and systems are restored to their proper operating condition.
- ▲ For vehicles with Automatic Traction Control (ATC), the ATC function must be disabled (ATC indicator lamp should be ON) prior to performing any vehicle maintenance where one or more wheels on a drive axle are lifted off the ground and moving.
- ▲ The power **MUST** be temporarily disconnected from the radar sensor whenever any tests **USING A DYNAMOMETER** are conducted on a Bendix® Wingman® Advanced™-equipped vehicle.
- ▲ You should consult the vehicle manufacturer's operating and service manuals, and any related literature, in conjunction with the Guidelines above.

DESCRIPTION

The Bendix® SV-1™ synchro valve and the Bendix® SV-3™ trailer release valves are pilot operated, non-graduating pneumatic control valves. These valves are used to control air from a remote supply, have set opening and closing pressures and can be used to delay or sequence the action of other pneumatic devices.

GENERAL

The SV-1 synchro valve (figure 1) and SV-3 & Bendix® SV-4™ trailer release valves (figure 2) are air controlled, "on-off" (non-graduating) control valves that are primarily used to delay or sequence various devices and events in the air brake system. These valves can be operated either in an automatic or manual mode using different air connection methods.

Two .28 inch diameter mounting holes are provided in the die cast aluminum body for panel — or frame — mounting. Two hex cap nuts at the ends of the cylindrical valve body retain the internal components. The air connection ports for the SV-1, SV-3 & SV-4 valves are the same — and are located in relatively the same position — on each model. All connections are pipe thread. Lettering embossed in the valve body identifies two of the four connection ports in these valves. Refer to the chart below and Figures 1 & 2.

Air Connection	Port I.D.	Thread Size
Supply	SUP	1/4" PT
Delivery	DEL	1/4" PT
Control	None	1/4" PT
Exhaust	None	1/8" PT

IMPORTANT: An exhaust check valve should be installed in the threaded exhaust port of these valves when they are mounted outside the cab in unprotected environments.



FIGURE 3 - EXHAUST CHECK VALVE

SV-1 Synchro Valve

The SV-1 valve is a general purpose valve used in a variety of applications on trucks, buses, tractors, trailers and converter dollies. The SV-1 valve is the base valve from which both the SV-3 and SV-4 valves are derived. It is offered in a variety of pressure settings to accommodate applications where automatic operation is required. It is easily distinguished from the SV-3 and SV-4 valve by its smaller size.

Bendix® SV-3™ Trailer Release Valve

While originally designed for automatic operation to accomplish brake release on trailers without spring brakes, the Bendix® SV-3™ valve can be used in any installation where its single automatic pressure setting is advantageous. The SV-3 valve is very similar in appearance to the Bendix® SV-4™ valve but can be distinguished by measuring the length and diameter of the supply hex cap nut (1/4" PT supply port). See the comparison chart for the dimensions.

Bendix SV-4 Trailer Release Valve

The SV-4 valve was designed primarily for use on trailer converter dollies to minimize the possibility of false charging. Like the SV-3 valve, it can be used in other applications. The SV-4 valve is the combination of two valves — an SV-3 valve and a single check valve. A typical installation is illustrated in Figure 4. The SV-4 valve can be distinguished from the SV-3 valve using the dimensions given in the comparison chart below. In addition, the tip of the check valve contained in the SV-4 valve is visible at the bottom of the 1/4" PT supply port.

Bendix® SV-3™/SV-4™ Valve Comparison Supply Cap Nut Dimensions		
Valve	Diameter	Length
SV-3	.81"	1.162"
SV-4	.94"	1.062"

OPERATION

GENERAL

The SV-1, SV-3 & SV-4 valves all operate in a similar fashion. All can be connected in the air system so that other valves control them. When connected in this non-automatic mode, the valve serves as a remote-mounted, on-off control. They can also be installed so that they function automatically, or self-actuate, at a preset pressure. Automatic operation is the most common application. Regardless of how they are connected, the internal valve operation is the same.

NON-AUTOMATIC (valve controlled remotely by another valve)

With no air pressure present at the control port, supply port air pressure and the inlet/exhaust valve spring hold the inlet valve on its seat in the body. The piston is held away from the inlet/exhaust valve by the piston spring, and the delivery line is vented to atmosphere through the hollow exhaust stem of the piston.

When sufficient air pressure is applied to the control port, the control piston moves against the resistance of its return spring. As the control piston moves, it contacts the exhaust valve portion of the inlet and exhaust valve (which seals the hollow exhaust passage in the piston stem). Continued piston movement drives the inlet valve from its seat and allows supply air to flow through the body and out the delivery port.

When air pressure is removed from the control port, the piston return spring and delivery port air pressure move the piston away from the inlet/exhaust valve. As the piston moves, the inlet valve re-seats itself, preventing air flow to the delivery port. Continued movement unseats the hollow exhaust passage in the piston stem, allowing delivery air to flow through the stem and out the exhaust check valve.

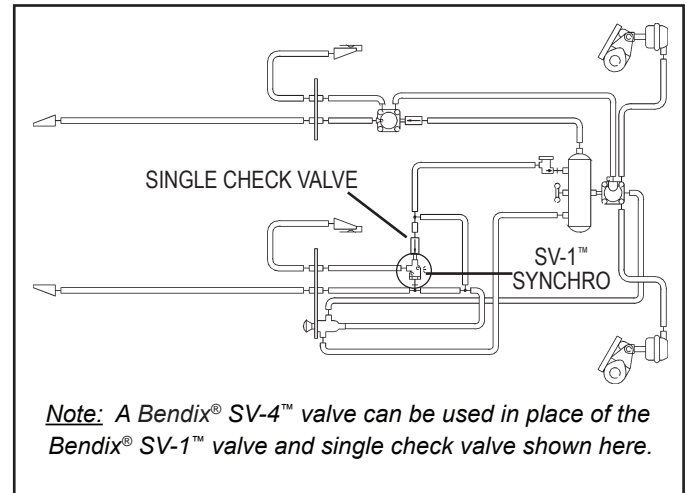

FIGURE 4 - TRAILER CONVERTER DOLLY

AUTOMATIC (self actuating at a pre-set pressure)

There are two methods for accomplishing automatic operation of an SV valve.

1. One method for affecting automatic operation is to connect the SV valve control port to its supply port using a pipe or tubing tee. This is referred to as "common control and supply" since the pressure at the supply and control port is the same.

With common control and supply, the valve opens (delivers air) on ascending supply air pressure and closes (and exhausts) on descending pressure. The pressure at which delivery and exhaust occurs differs for various part numbers. Opening and exhaust pressure is specified for the various part numbers.

2. SV valves can be made to operate automatically even when the supply port and control ports are separate (not connected as described in #1 above).

The SV valve will open (deliver air) and close (exhaust) when control port pressure is increased or decreased. Consult with Bendix Engineering for specific control port pressure for valve opening and closing when this type of automatic operation is used. When using the SV-1 synchro valve in this manner, the control signal ramp rate should be limited by orificing or other methods. Please contact Bendix Engineering with specific application requirements.

PREVENTIVE MAINTENANCE

Important: Review the Bendix Warranty Policy before performing any intrusive maintenance procedures. A warranty may be voided if intrusive maintenance is performed during the warranty period.

No two vehicles operate under identical conditions, as a result, maintenance intervals may vary. Experience is a valuable guide in determining the best maintenance interval for air brake system components. At a minimum, the SV valves should be inspected every six (6) months or 1500 operating hours, whichever comes first, for proper operation. Should the SV valves not meet the elements of the operational tests noted in this document, further investigation and service of the valve may be required.

If the Bendix® SV-1™, SV-3™, or SV-4™ valve fails to function as described or leakage is excessive, it should be repaired or replaced with a Genuine Bendix valve, available at any authorized parts outlet.

OPERATING AND LEAKAGE TESTS

OPERATING TEST

Two accurate air gauges are necessary to perform these tests. Depending upon installation, it may be necessary to remove the valve to properly test it. Correct opening pressures of the valve should be known before beginning tests; consult the vehicle manual.

1. Install an accurate gauge in the common control and supply line; install another gauge in the delivery port.
2. Gradually apply air pressure to the common supply and control line. As common supply and control pressure increases, note at what pressure delivery of air through valve is made and compare with specifications in vehicle manual.
3. Slowly decrease pressure in the common supply and note at what pressure delivery line pressure is vented; compare with vehicle manual.
4. Pay particular attention to the exhaust check valve in the exhaust port if so equipped (see Figure 3). Make certain it is free of contamination and the rubber valve is free to function. Replace this item as necessary.

LEAKAGE TEST

1. With 120 psi air pressure present in supply, control and delivery ports:
 - Apply a soap solution around control port cap nut and supply port cap nut. No leakage is permitted.
 - Apply soap solution to the exhaust port; leakage must not exceed a 1" bubble in less than 5 seconds (100 sccm).
Excessive leakage would indicate a faulty o-ring, inlet/exhaust valve or piston exhaust seat.
2. Plug the delivery port and apply 10 psi to the supply port only. Apply soap solution to the exhaust port:
 - For the SV-1 valve - leakage must not exceed a 1" bubble in less than 5 seconds (100 sccm).

- For the SV-3 & SV-4 valves - leakage must not exceed a one (1) inch bubble in less than 10 seconds (50 sccm).
Excessive leakage would indicate a faulty inlet valve or inlet valve seat.

If the valve does not function as described, or if leakage is excessive, it is recommended that it be replaced with a new unit, or repaired with Genuine Bendix parts available at Bendix outlets.

REMOVING AND INSTALLING

REMOVING

1. Block and hold the vehicle by means other than air brakes.
2. Drain the air brake system.
3. Identify the air lines to facilitate re-installation, disconnect the lines, remove the mounting bolts, and then the valve.

INSTALLING

1. Mount the valve securely.
2. Check and clean air lines; identify air lines and connect to valve.

DISASSEMBLY

1. Remove the control port cap nut and its o-ring. Remove the o-ring from the cap nut.
2. Remove the piston from the valve body. Remove the large and small piston o-rings from the piston.
3. Remove the piston return spring from the body.
4. Remove the supply port cap nut and its o-ring. Remove the o-ring from the cap nut.
5. Remove the inlet/exhaust valve stop (SV-1 valve) or the spring guide (SV-3 & SV-4 valve), then the inlet/exhaust valve spring.
Note: The SV-4 valve contains a check valve which is installed in the opposite end of the inlet/exhaust valve return spring.
6. Remove the inlet/exhaust valve.
7. Remove the exhaust check valve if so equipped.

CLEANING AND INSPECTION

1. Using good commercial grade of solvent, clean and thoroughly dry all metal parts. Do not damage bores with metal tools.
2. Inspect the interior and exterior of all metal parts that will be reused for severe corrosion, pitting and cracks. Superficial corrosion and/or pitting on the exterior portion of the body and cap nuts is acceptable. Replace the entire valve if the interior of the body or cap nuts exhibit signs of corrosion or pitting.
3. Inspect the body bore and the check valve seat in the supply port cap nut of the SV-4 valve for deep scuffing or gouges. Replace the entire valve if either are found.

4. Inspect the pipe threads in the body and cap nuts. Make certain they are clean and free of thread sealant.
5. Inspect all springs for signs of corrosion, pitting and cracks. Replace as necessary.
6. Inspect all air line fittings for corrosion and replace as necessary. Make certain to remove all old thread sealant before reuse.
7. Inspect the exhaust check valve making certain all passages are clear and open.

ASSEMBLY

Prior to assembly, lubricate the piston, o-rings and body bores with Dow-Corning 55-M pneumatic grease (Bendix Piece No. 291126).

1. Install the inlet/exhaust valve in the body.
2. Install the inlet valve spring and valve stop (Bendix® SV-1™ valve) or spring guide (Bendix® SV-3™ & SV-4™ valve).

Note: Install the check valve in the small diameter end of the inlet-exhaust valve return spring of the SV-4 valve before installing in the body.

3. Install the o-ring on the supply cap nut then install and tighten the cap nut. Torque to approximately 100 in-lbs.
4. Install the piston return spring in the body.
5. Install the small and large diameter o-rings on the piston. Insert the piston into body. (Piston should now rest on top of the spring.)
6. Install the control port cap nut o-ring on the cap nut then install and tighten the cap nut in body. Torque to approximately 275 in-lbs.
7. Install the exhaust check valve if the valve assembly was so equipped.
8. Perform tests as outlined in the "Operating and Leakage Tests" section.



Log-on and Learn from the Best

On-line training that's available when you are – 24/7/365.
Visit www.brake-school.com.