



Installation Instructions

BENDIX® AD-9® AIR DRYER PURGE VALVE ASSEMBLY REPLACEMENT KITS

Standard Purge Valve Assembly

Soft Seat:
800405 (5004341X Rx) (12v),
5004338 (5004342X Rx) (24V)

Hard Seat:
5004479 (K040545 Rx) (12V),
5004480 (24V-75W)
& 5004381 (24V-100W)

Standard Purge Valve Assembly Kit Contents

Item	Description	Qty
1	Purge Valve Assembly	1
2	1/4" Cap Screw & Washer	3
3	Washer	3
4	O-ring (small)	1
5	O-ring (large)	1
6	O-ring (medium)	1
7	Lubricant	1

Discharge Line Unloader (DLU) Purge Valve Assembly Kit Contents

5004339 (12V)
5004340 (24V-75W)
& 5006580 (24V-100 W)

DLU Purge Valve Assembly Kit Contents

Item	Description	Qty
1	Purge Valve Assembly	1
2	1/4" Cap Screw & Washer	3
3	Washer	3
4	O-ring (small)	1
5	O-ring (large)	1
7	Lubricant	1

Letter "U" stamped here on older style purge valves to identify DLU assembly

FIGURE 1 BENDIX® AD-9® AIR DRYER PURGE VALVE KIT CONTENTS

GENERAL SAFETY GUIDELINES

WARNING!

PLEASE READ AND FOLLOW THESE INSTRUCTIONS TO AVOID PERSONAL INJURY OR DEATH:

When working on or around a vehicle, the following general precautions should be observed **at all times**.

1. Park the vehicle on a level surface, apply the parking brakes, and always block the wheels. Always wear safety glasses.
2. Stop the engine and remove ignition key when working under or around the vehicle. When working in the engine compartment, the engine should be shut off and the ignition key should be removed. Where circumstances require that the engine be in operation, **EXTREME CAUTION** should be used to prevent personal injury resulting from contact with moving, rotating, leaking, heated or electrically charged components.
3. Do not attempt to install, remove, disassemble or assemble a component until you have read and thoroughly understand the recommended procedures. Use only the proper tools and observe all precautions pertaining to use of those tools.
4. If the work is being performed on the vehicle's air brake system, or any auxiliary pressurized air systems, make certain to drain the air pressure from all reservoirs before beginning **ANY** work on the vehicle. If the vehicle is equipped with a Bendix® AD-IS® air dryer system or a dryer reservoir module, be sure to drain the purge reservoir.
5. Following the vehicle manufacturer's recommended procedures, deactivate the electrical system in a manner that safely removes all electrical power from the vehicle.
6. Never exceed manufacturer's recommended pressures.
7. Never connect or disconnect a hose or line containing pressure; it may whip. Never remove a component or plug unless you are certain all system pressure has been depleted.
8. Use only genuine Bendix® brand replacement parts, components and kits. Replacement hardware, tubing, hose, fittings, etc. must be of equivalent size, type and strength as original equipment and be designed specifically for such applications and systems.
9. Components with stripped threads or damaged parts should be replaced rather than repaired. Do not attempt repairs requiring machining or welding unless specifically stated and approved by the vehicle and component manufacturer.
10. Prior to returning the vehicle to service, make certain all components and systems are restored to their proper operating condition.
11. For vehicles with Automatic Traction Control (ATC), the ATC function must be disabled (ATC indicator lamp should be ON) prior to performing any vehicle maintenance where one or more wheels on a drive axle are lifted off the ground and moving.

CAUTION: Prior to assembly of any kit, coat all o-rings, o-ring grooves and bores with a barium base lubricant. Refer to Figure 1 during assembly unless otherwise advised.

GENERAL INFORMATION

Several changes have been made to the Bendix® AD-9® air dryer purge valve assembly. Study Figure 1 closely when replacing the purge valve assembly.

CLEANING AND INSPECTION

1. Using mineral spirits or an equivalent solvent, clean and thoroughly dry all metal parts.
2. Inspect the interior and exterior of all metal parts that will be reused for severe corrosion, pitting and cracks. Superficial corrosion and/or pitting on the exterior is acceptable.
3. Inspect the bores of both the end cover and the purge valve housing and seats for deep scuffing or gouges.
4. Inspect the purge valve piston seat for excessive wear.
5. All o-rings removed should be discarded and replaced with new o-rings provided in this kit. Any component exhibiting a condition described in steps 1 through 4 should be replaced.

PURGE VALVE ASSEMBLY REMOVAL

(Refer to Figure 1 unless otherwise noted.)

1. Disconnect the vehicle wiring harness connector that mates with the connector on the purge valve assembly. Make sure the connector seal is present on the wire harness. Refer to Figure 2.
2. If a silencer is installed, pull the silencer down away from the end cover to remove it. Refer to Figure 3.

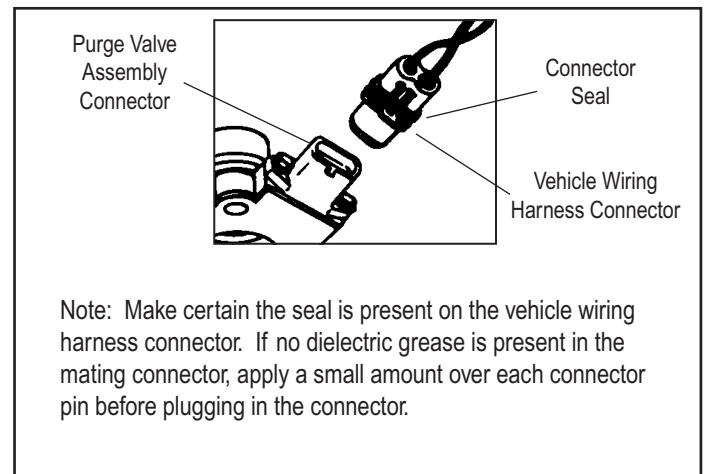

Figure 2 **Wiring Harness Connectors**

3. Remove and discard the three 1/4" self-tapping screws(2) that secure the purge valve assembly to the end cover and the three flat washers (3), if present. Note: AD-9 air dryers with extended covers do not have flat washers (3).
4. Pull the purge valve assembly (1) out of the end cover. Discard o-rings (4, 5 and 6). O-rings (4) and/or (5) may be lodged in the end cover bores, be sure to remove these. Note: DLU style purge valves do not have an o-ring (5) or an o-ring groove in the purge valve housing. Refer to Figure 4.
5. Verify the purge valve assembly (1) contained in the kit is the same type as the one removed. See Figures 4 and 5 for types of purge valve assemblies. Once the purge valve assembly is verified, check with an authorized Bendix parts outlet for possible core value for the purge valve assembly before discarding.

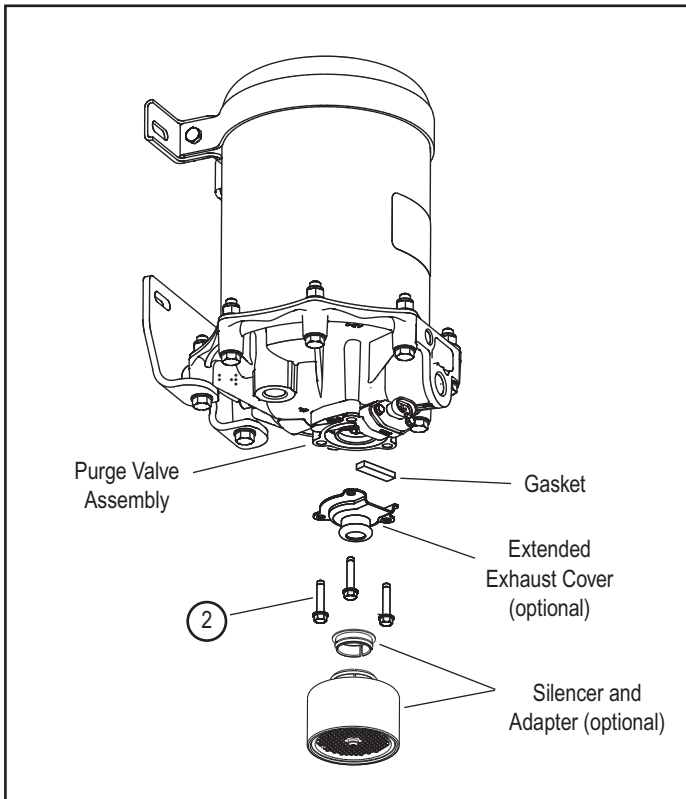

Figure 3 Air Dryer Silencer And Extended Cover Removal

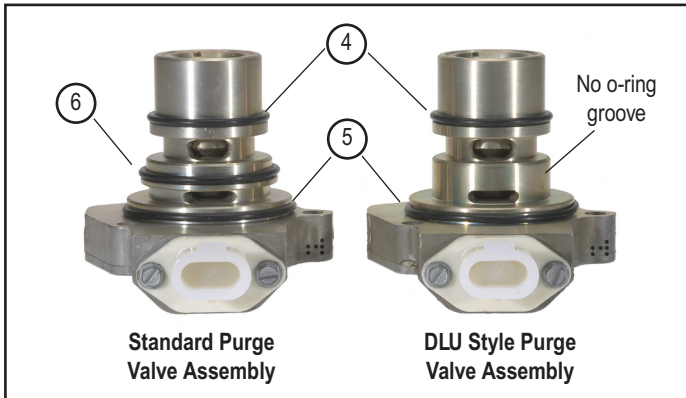

Figure 4 Standard and DLU Style Purge Valve Identification

6. NOTE: In some cases, an older style extended type exhaust cover is used to accommodate the attachment of an exhaust hose or silencer. Refer to Figure 6.

This older style extended exhaust cover can not be used with the purge valve assembly provided in this kit. To accommodate the use of an exhaust hose, use Bendix® exhaust cover kit piece number 5003838. To accommodate the use of a silencer use Bendix® silencer kit piece number 5004224.

PURGE VALVE ASSEMBLY INSTALLATION

1. Lubricate the o-rings (4, 5 and 6) and the o-ring grooves of the purge valve housing using the lubricant (7) provided. Note that there are three sizes of o-rings. The smallest is o-ring (4), the middle size is o-ring (6) and the largest is o-ring (5). Install all three o-rings in their respective

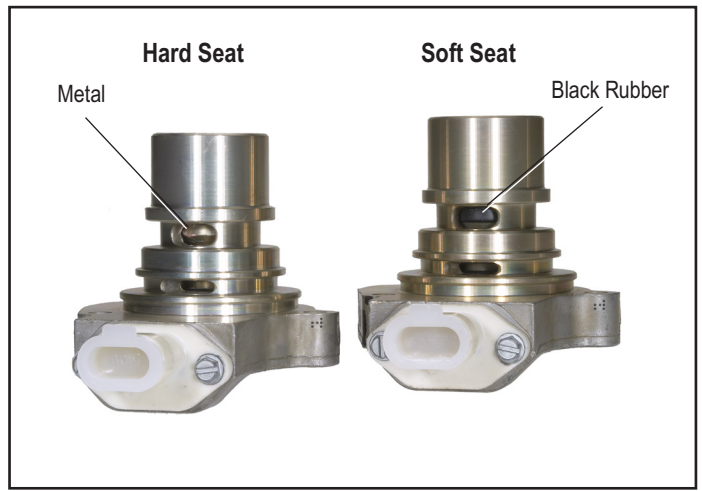

Figure 5 Hard Seat and Soft Seat Purge Valve Assemblies

o-ring grooves on the purge valve housing. Use care to not twist the o-rings. Note that DLU style purge valves do not use o-ring (6). Refer to Figure 4.

2. Lubricate the air dryer bore for the purge valve assembly (1). Important: Use only the lubricant (7) packaged with this kit.
3. Install the purge valve assembly in the end cover making certain to orient both parts such that the connector is approximately 10 degrees clockwise from the supply port, while making certain the purge valve assembly is fully seated against the end cover. **CAUTION:** Carefully ease the purge valve assembly into position (using a gentle twisting motion if necessary). Do not force the purge piston as serious damage may result.
4. If replacing an extended exhaust cover, verify the gasket was not damaged during removal. If necessary, repair with silicone sealant (Dow Corning® 736 or 732 RTV) or replace the extended cover assembly. Install the extended cover on the purge valve assembly aligning the cover with the contour of the purge valve housing.
5. Secure the purge valve assembly and/or extended exhaust cover to the end cover, using the three 1/4" self-tapping screws (2) and 1/4" washers (3), if applicable. The 1/4" washers (3) should not be used with the extended exhaust cover. Start all three screws by hand then torque to 85–125 in-lbs.

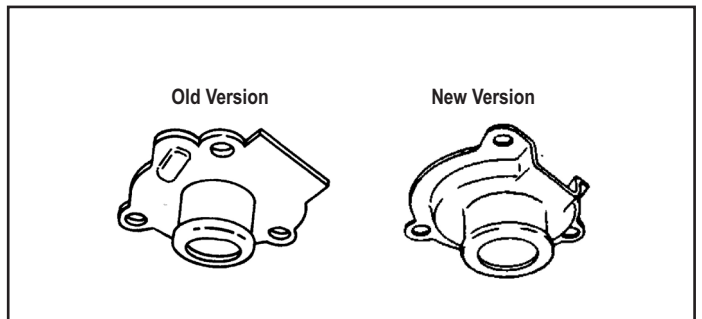

Figure 6 Extended Exhaust Covers

6. Test for vehicle power at the two pins of the vehicle wiring harness connector. The vehicle battery voltage should be detected with the ignition ON. If voltage is not detected, check for broken or pinched wiring.
 7. Re-connect the vehicle wiring harness connector to the purge valve assembly. (*Refer to Figure 2 and read all notes.*)
 8. Re-install exhaust hose or silencer if previously removed.
 9. Complete the "Operation and Leakage Tests" to verify the air dryer is functioning properly.
3. Check the operation of the end cover heater and thermostat assembly during cold weather operation as follows:
 - A. Electric Power to the Dryer

With the ignition or engine kill switch in the ON position, check for voltage to the heater and thermostat assembly using a voltmeter or test light. Unplug the electrical connector at the air dryer and place the test leads on each of the pins of the male connector. If there is no voltage, look for a blown fuse, broken wires, or corrosion in the vehicle wiring harness. Check to see if a good ground path exists. *Refer to Figure 2.*
 - B. Thermostat and Heater Operation

Turn off the ignition switch and cool the end cover assembly to below 40° Fahrenheit. Using an ohmmeter, check the resistance between the electrical pins in the female connector. The resistance should be between 1.0 and 3.0 ohms for the 12 volt heater assembly and 4.8 to 9.0 ohms for the 24 volt heater assembly. If the resistance is higher than the maximum stated, replace the purge valve assembly, which includes the heater and thermostat (old versions style A & B), or replace the heater and thermostat assembly in the new version purge valve assemblies (standard and DLU style).

Warm the end cover assembly to over 90° Fahrenheit and again check the resistance. The resistance should exceed 1000 ohms. If the resistance values obtained are within the stated limits, the thermostat and heater is operating properly. If the resistance values obtained are outside the stated limits, replace the heater or purge valve assembly.

OPERATION AND LEAKAGE TESTS

1. Close all reservoir drain cocks. Build up system pressure to governor cut-out and note that the Bendix® AD-9® air dryer purges with an audible escape of air. "Fan" the service brakes to reduce system air pressure to governor cut-in. Note that the system once again builds to full pressure and is followed by an air dryer purge.

OPTIONAL OPERATION AND LEAKAGE TESTS

1. Test the delivery port check valve by building the air system to governor cut-out and observing a test air gauge installed in the #1 reservoir. Check all lines and fittings leading to and from the air dryer for leakage and integrity. A rapid loss of pressure could indicate a failed delivery check valve. This can be confirmed by bleeding the system down, removing the check valve assembly from the end cover. Bench test by applying air pressure to the check valve and soaping the other end. Leakage should not exceed a one inch bubble in one second.
2. Check for excessive leakage of the purge valve. With the compressor loaded (compressing air), apply a soap solution to the purge valve housing assembly exhaust port and observe that leakage does not exceed a one inch bubble in one second. If the leakage exceeds the maximum specified, service the purge valve housing assembly.

Log-on and Learn from the Best

On-line training that's available when you are—24/7/365.
Visit www.brake-school.com.