



Installation Instructions

BENDIX® AD-SP® SYSTEM PURGE REPLACEMENT AIR DRYER

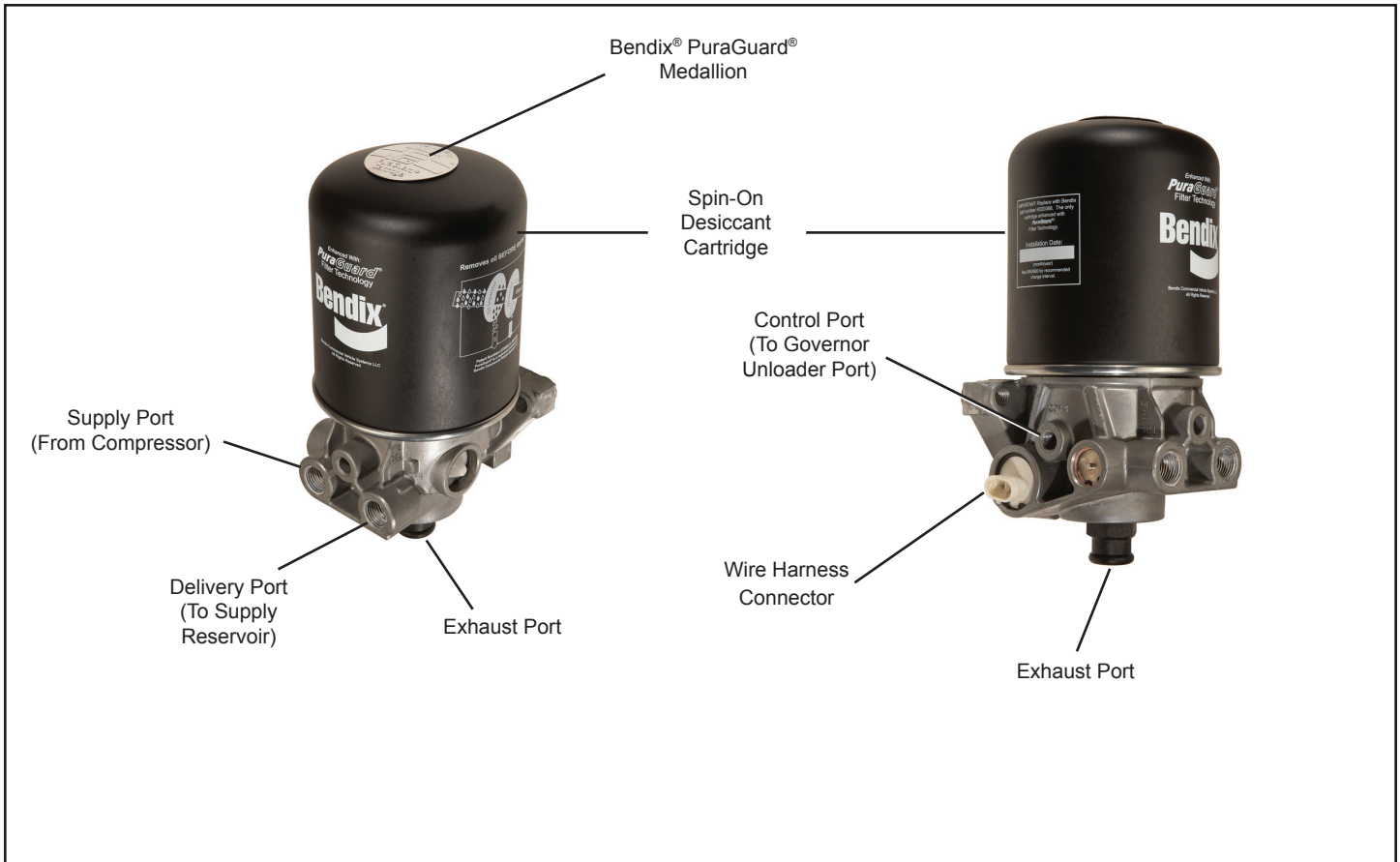

Figure 1 Bendix® AD-SP® System Purge Air Dryer



Please Read Before Installing

This service air dryer is intended for replacement of an existing Bendix® AD-SP® system purge air dryer or an air dryer of the same type. Bendix AD-SP air dryer kits are available for retrofitting a vehicle that does not have an AD-SP air dryer or an equivalent dryer. These kits include an AD-SP air dryer and a Bendix® SC-PR™ valve.



GENERAL SAFETY GUIDELINES

WARNING! PLEASE READ AND FOLLOW THESE INSTRUCTIONS

TO AVOID PERSONAL INJURY OR DEATH:

When working on or around a vehicle, the following guidelines should be observed AT ALL TIMES:

- ▲ Park the vehicle on a level surface, apply the parking brakes and always block the wheels. Always wear personal protection equipment.
- ▲ Stop the engine and remove the ignition key when working under or around the vehicle. When working in the engine compartment, the engine should be shut off and the ignition key should be removed. Where circumstances require that the engine be in operation, **EXTREME CAUTION** should be used to prevent personal injury resulting from contact with moving, rotating, leaking, heated or electrically-charged components.
- ▲ Do not attempt to install, remove, disassemble or assemble a component until you have read, and thoroughly understand, the recommended procedures. Use only the proper tools and observe all precautions pertaining to use of those tools.
- ▲ If the work is being performed on the vehicle's air brake system, or any auxiliary pressurized air systems, make certain to drain the air pressure from all reservoirs before beginning **ANY** work on the vehicle. If the vehicle is equipped with a Bendix® AD-IS® air dryer system, a Bendix® DRM™ dryer reservoir module, or a Bendix® AD-9si® air dryer, be sure to drain the purge reservoir.
- ▲ Following the vehicle manufacturer's recommended procedures, deactivate the electrical system in a manner that safely removes all electrical power from the vehicle.
- ▲ Never exceed manufacturer's recommended pressures.
- ▲ Never connect or disconnect a hose or line containing pressure; it may whip and/or cause hazardous airborne dust and dirt particles. Wear eye protection. Slowly open connections with care, and verify that no pressure is present. Never remove a component or plug unless you are certain all system pressure has been depleted.
- ▲ Use only genuine Bendix® brand replacement parts, components and kits. Replacement hardware, tubing, hose, fittings, wiring, etc. must be of equivalent size, type and strength as original equipment and be designed specifically for such applications and systems.
- ▲ Components with stripped threads or damaged parts should be replaced rather than repaired. Do not attempt repairs requiring machining or welding unless specifically stated and approved by the vehicle and component manufacturer.
- ▲ Prior to returning the vehicle to service, make certain all components and systems are restored to their proper operating condition.
- ▲ For vehicles with Automatic Traction Control (ATC), the ATC function must be disabled (ATC indicator lamp should be ON) prior to performing any vehicle maintenance where one or more wheels on a drive axle are lifted off the ground and moving.
- ▲ The power **MUST** be temporarily disconnected from the radar sensor whenever any tests **USING A DYNAMOMETER** are conducted on a vehicle equipped with a Bendix® Wingman® system.
- ▲ You should consult the vehicle manufacturer's operating and service manuals, and any related literature, in conjunction with the Guidelines above.

INSTALLING THE BENDIX® AD-SP® AIR DRYER

1. Mount the Bendix® AD-SP® air dryer on the vehicle using three 1/2" bolts (grade 5 min.) of the proper length and washers. Torque to 50 lb-ft.
2. **IMPORTANT:** The length of the three mounting bolts used to attach the AD-SP air dryer to the mounting plate is very important. *Refer to figure 3.*



CAUTION

The threaded end of the 1/2"-13 UNC bolt must be between 1/8" below to 1/4" above the surface of the AD-SP air dryer mounting bracket surface when **fully installed and tightened to 50 lb-ft**. Damage to the AD-SP air dryer body will result if the bolt warning is ignored. Measure the thicknesses of all materials that the three mounting bolts must pass through. Small adjustments can be made using flat washers under the bolt heads. Do not use more than three (3) flat washers. *Refer to Figure 3.*

3. Install the supply, delivery, and control port air lines using the markings and identification made in step 3 under "PREPARATION".
4. If so equipped, re-connect the exhaust line to the exhaust port of the air dryer.

WIRING THE HEATER/THERMOSTAT

Determine the vehicle's electrical system voltage and make certain that the AD-SP air dryer to be installed contains the same voltage heater. Use the air dryer part number to confirm the proper voltage. The AD-SP air dryer is available with either a 12 or 24 volt heater and each uses 90 watts of power. Wire harness and splice kits are available from authorized Bendix® parts outlets.

TESTING THE BENDIX AD-SP AIR DRYER

General Operational Statement

The Bendix AD-SP system purge air dryer operates differently than integral purge air dryers such as the Bendix® AD-9® air dryer. The "system purge" designation is used because this air dryer uses a small portion of the supply and front axle (secondary) reservoir air pressure to purge, or dry, the desiccant material. During the purge cycle, an approximately 10 psi drop in air pressure will be noted on the front axle (secondary) service reservoir dash gauge. The drop in pressure is the result of using a small amount of air from the reservoir to purge the AD-SP air dryer desiccant.

The Bendix® SC-PR™ valve, installed in the vehicle air system, allows the purge air to be drawn from the secondary reservoir. It also protects the air pressure in the front axle (secondary) service reservoir in the event of a compressor, supply or rear axle reservoir failure or malfunction of the AD-SP purge control valving.

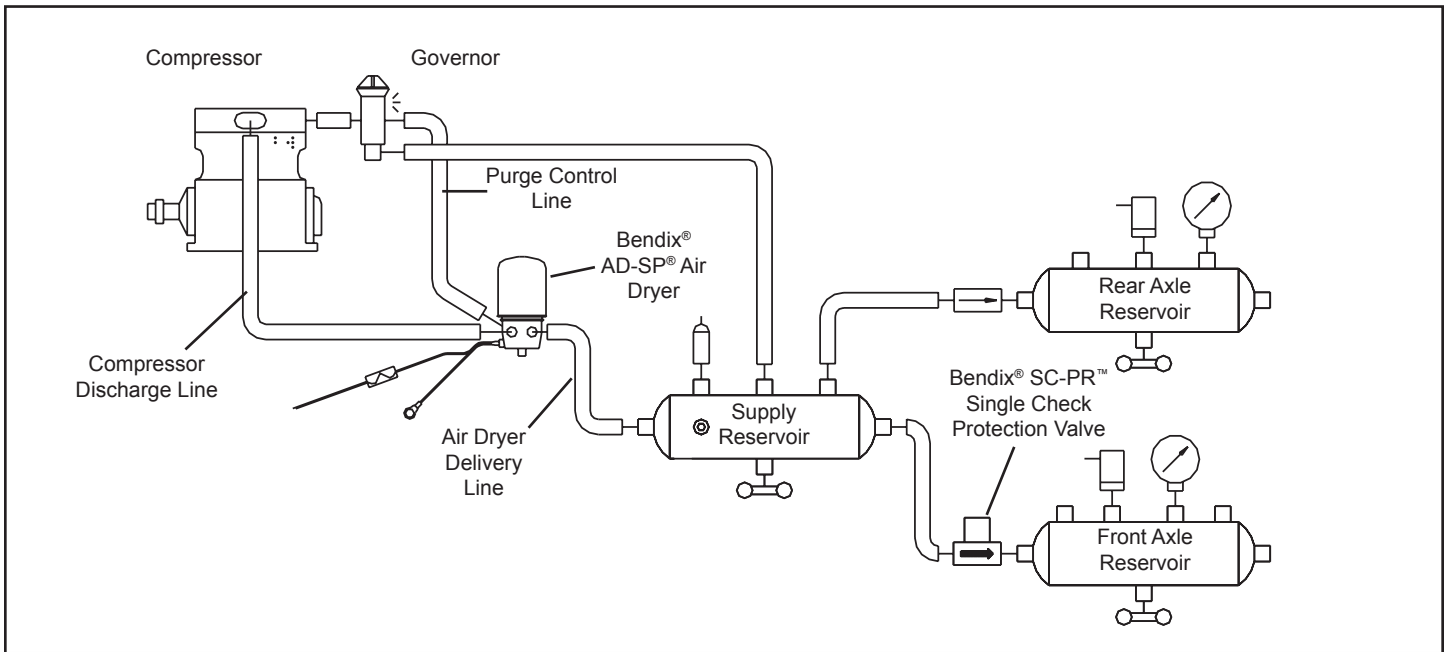

Figure 2 Bendix® AD-SP® Air Dryer Installation With Bendix® SC-PR® Valve

▲ IMPORTANT

The vehicle must be equipped with a Bendix® SC-PR™ valve or an equivalent. To determine if the vehicle is equipped with an SC-PR valve and that it is functional, make certain to perform test 5 under the heading "TESTING". If the vehicle does not have an SC-PR valve installed or if the valve does not function as described in the test, install or replace the valve before placing the vehicle in service.

Testing Procedure

Before placing the vehicle in service, perform the following tests.

1. Close all reservoir drain cocks.
2. Build up system pressure to governor cut-out while observing that both the front axle (secondary) and rear axle service reservoir dash gauges rise equally in pressure from 0 psi to governor cut-out. If either gauge fails to display this condition, stop testing and check the installation of the SC-PR. Note that the AD-SP purges with an audible escape of air when governor cut-out pressure is reached.
3. Note that the front axle (secondary) service reservoir pressure drops approximately 10 psi and that the rear axle service reservoir loses no air pressure.
4. Rapidly apply the service brakes several times to reduce system air pressure to governor cut-in. Note that the system once again builds to full pressure and is followed by a purge at the AD-SP air dryer exhaust.

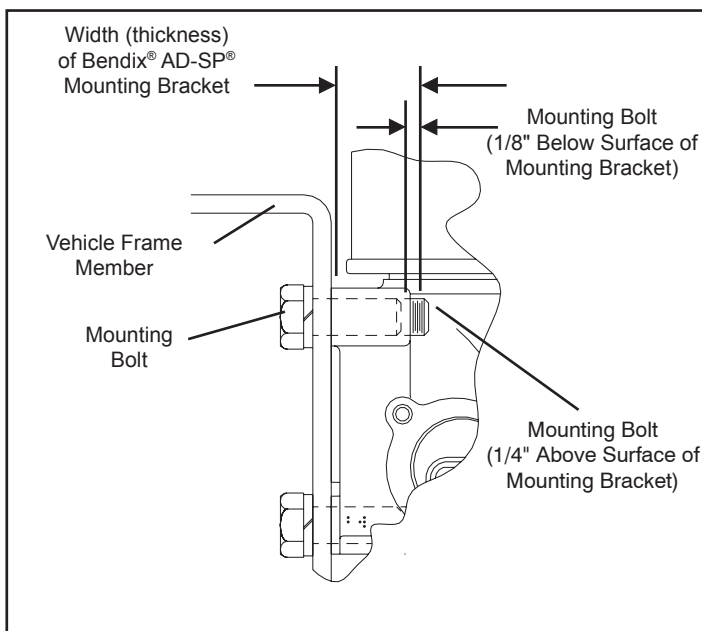

Figure 3 Bendix® AD-SP® Air Dryer Mounting Bracket Bolt Length Limits

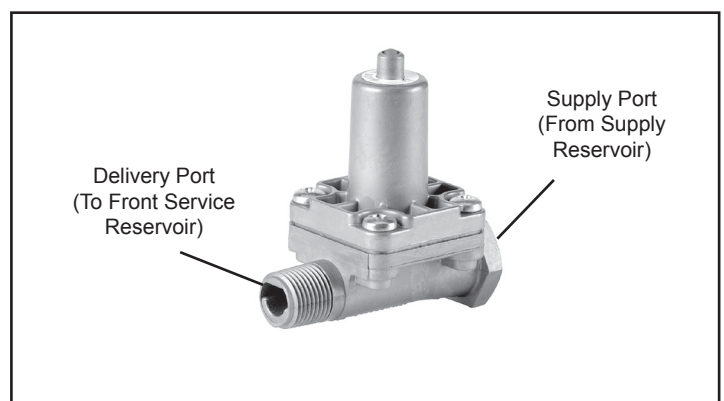

Figure 4 Bendix® SC-PR™ Single Check Protection Valve

5. Test the operation of the Bendix® SC-PR™ valve. Build system air pressure to governor cut-out and turn the ignition off. Drain the supply reservoir and note that pressure in the front axle (secondary) service reservoir does not drop below 90 psi.
6. It is recommended that the following items be tested for leakage to ensure that the Bendix® AD-SP® will not cycle excessively.
 - (A) Total air system leakage (See Bendix publication BW-5057 "Air Brake Handbook")
 - (B) Compressor unloader mechanism
 - (C) Governor
 - (D) Drain cock and safety valve in first (supply) reservoir.
 - (E) All air connections leading to and from the first (supply) reservoir.



Log-on and Learn from the Best

On-line training that's available when you are –24/7/365.
Visit www.brake-school.com.