

VOLVO[®]

**QUICK
REFERENCE
GUIDE**

EPA2007 D13F Engine

PV776-QRG07-D13F
November 2009

© Volvo Group North America, Inc. 2009
Printed in U.S.A.

VOLVO EPA2007 D13F Engine

QUICK REFERENCE GUIDE

PV776-QRG07-D13F

VOLVO[®]

**QUICK
REFERENCE
GUIDE**

EPA2007 D13F Engine

PV776-QRG07-D13F
November 2009

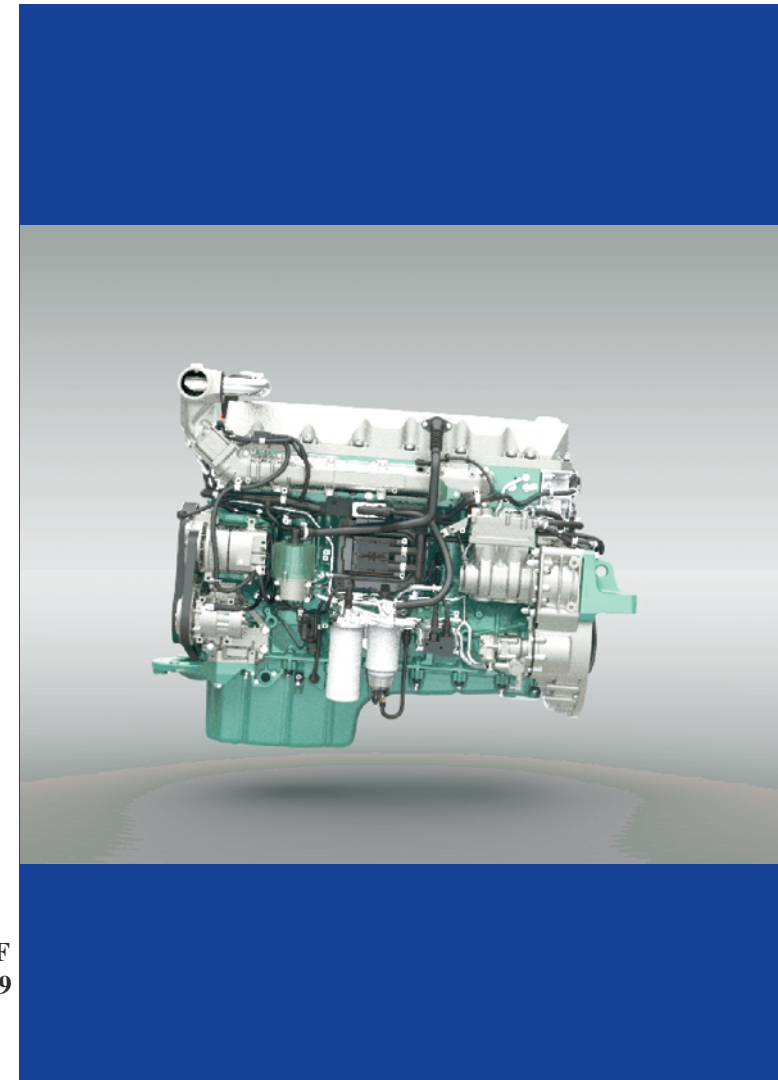

Contents

GENERAL INFORMATION	1
Specifications	1
Safety Information	1
Service Procedures and Tool Usage	2
About the Volvo D13F Engine	4
D13F Engine Model Identification	6
Service At a Glance	7
Service Precautions Summary	9
Engine Serial Number Identification	10
SPECIFICATIONS.....	11
Engine Specification	11
Tightening Torques and Patterns.....	16
Sensors and Wiring Harness	16
Engine Component Torque Specifications (Critical Fasteners)	47
Fastener Reuse	47
Gasket and Seal Reuse	50
Engine Lubricants and Sealants	52
Engine Fault Codes.....	53
Conversion Chart	59
Engine Dimensions	65
Cylinder Head.....	65
Cylinder Head Bolts.....	65
Cylinder Block	65
Cylinder Liner	65
Piston	65
Piston Rings	66
Valve Mechanism.....	67
Rocker Arms	67
Valve Guides	68
Valve Springs	68
Engine Timing Gear.....	69
Camshaft	70
Camshaft Bearings.....	71
Crank Mechanism Main Bearing Journals.....	71
Thrust Washers (Axial Bearing)	72
Main Bearings.....	72
Connecting Rod Journals	73
Connecting Rod Bearings	74
Connecting Rod	74
Flywheel, Mounted	75
Flywheel Housing, Mounted.....	75
Crankshaft.....	75
ENGINE COMPONENT AND LOCATION	76
Cylinder Head	76
Camshaft and Valve Train.....	77

Cylinder Block	80
Head to Block Alignment	81
Cylinder Head Gasket	82
Cylinder Liner	83
Oil Pan	84
Crankshaft	85
Piston and Connecting Rods	86
Timing Gears	88
Drive Belt	89
Lubrication System	90
Oil Pump	90
Oil Flow Control and Filtration	91
Crankcase Ventilation	93
Fuel System	95
Fuel Filtration	97
Unit Injectors	98
Volvo Engine Brake	101
Exhaust Gas Recirculation System	104
EGR Valve	105
EGR Valve Function	105
EGR Cooler Inlet Pipe	106
EGR Cooler	107
EGR Venturi System	107
EGR Cooler Outlet Pipe	107
EGR Mixer	107
Inlet Air Heater	108
EGR Diagnostics	108
Air Intake System	109
Variable Geometry Turbocharger	109
Cooling System	110
Coolant Pump	110
Thermostat	111
Engine Cooling Fan	111
Engine Management System	112
Engine Electronic Control Unit (EECU)	112
Exhaust Aftertreatment System	113
Exhaust Gas Recirculation	113
Particulate Matter	113
Catalytic Filters	114
Diesel Oxidation Catalyst	114
Diesel Particulate Filter	115
Filter Regeneration	115
Passive Regeneration	115
Active Regeneration	116
Manual Regeneration	118
Discharge Recirculation Valve	118
Ultra Low Sulfur Diesel Fuel	118

Operational Mode	119
DPF System Vehicle Mounting.....	120
COMPONENT PART NUMBER LOCATOR	121
Engine, Right-Side View	121
Engine, Left-Side View	123
Engine, Front View	124
Engine Sensors	125
ENGINE DISASSEMBLED VIEW AND PART NUMBERS	126
Upper Engine Components	126
Rear Engine Components	128
Oil Pan and Stiffing Frame	130
Lower Engine Components.....	132
Replacement Kits.....	134
Engine Replacement Kits.....	134
BASIC SERVICE.....	136
Maintenance	136
Oil Level Check	136
Oil and Filter Change Procedure	137
Crankcase Ventilation System.....	137
Fuel Filter Replacement.....	138
Filter Description	138
Fuel Filter Replacement.....	139
Water Separating Pre-Filter Replacement.....	139
Full-Flow Main Filter Replacement.....	140
Cooling System Maintenance	140
Coolant Drain Outlets	140
Coolant Filter	141
Exhaust Aftertreatment System Maintenance.....	143
Diesel Particulate Filter.....	143
Compact Unit	143
Vertical Back-of-Cab Unit	147
Aftertreatment Fuel Injector (AFI)	152
Drive Belt Replacement and Tensioning	158
General Information.....	158
Automatically Tensioned System	158
Valve and Unit Injector Adjustment	159
General Information.....	160
Inlet Valve Adjustment	161
Unit Injector Adjustment	162
Exhaust Valve Adjustment (WITHOUT Volvo Engine Brake)	163
Exhaust Valve Adjustment (WITH Volvo Engine Brake)	164
Continuation of Adjustments	167
Operational Check	168
Glossary	169
GLOSSARY OF TERMS	169

Active Regeneration.....	169
Aftertreatment Fuel Injector (AFI)	169
Ash	169
Atmospheric Pressure Sensor	169
Carbon Monoxide (CO)	169
Catalyst	169
Combustion Air Temperature and Humidity Sensor	169
Compressor Discharge Temperature Sensor	170
Cooled Exhaust Gas Recirculation (CEGR)	170
Cordierite	170
Diesel Particulate Matter.....	170
Differential Pressure Sensors	170
Discharge Recirculation Valve (DRV)	170
Electronic Unit Injector (EUI)	171
Engine Electronic Control Unit (EECU)	171
Exhaust Aftertreatment System (EATS)	171
Exhaust Gas Recirculation (EGR)	171
Hydrocarbons (HC).....	171
Idler Gear	171
Idler Tensioner	172
Oxides of Nitrogen (NOx)	172
Passive Regeneration	172
Poly-V Belt	172
Regeneration	172
Roller Follower.....	172
Soot	173
Variable Geometry Turbocharger (VGT).....	173
VGT Wheel Speed	173
Vehicle Electronic Control Unit (VECU)	173

Specifications

Safety Information

Advisory Labels

Cautionary signal words (Danger-Warning-Caution) may appear in various locations throughout this manual. Information accented by one of these signal words must be observed to minimize the risk of personal injury to service personnel, or the possibility of improper service methods which may damage the vehicle or cause it to be unsafe. Additional Notes and Service Hints are used to emphasize areas of procedural importance and provide suggestions for ease of repair. The following definitions indicate the use of these advisory labels as they appear throughout the manual:



DANGER

Danger indicates an unsafe practice that could result in death or serious personal injury. Serious personal injury is considered to be permanent injury from which full recovery is NOT expected, resulting in a change in life style.



WARNING

Warning indicates an unsafe practice that could result in personal injury. Personal injury means that the injury is of a temporary nature and that full recovery is expected.



CAUTION

Caution indicates an unsafe practice that could result in damage to the product.

Note: Note indicates a procedure, practice, or condition that must be followed in order for the vehicle or component to function in the manner intended.

2 GENERAL INFORMATION

Service Procedures and Tool Usage

Anyone using a service procedure or tool not recommended in this manual must first satisfy himself thoroughly that neither his safety nor vehicle safety will be jeopardized by the service method he selects. Individuals deviating in any manner from the instructions provided assume all risks of consequential personal injury or damage to equipment involved. Also note that particular service procedures may require the use of a special tool(s) designed for a specific purpose. These special tools must be used in the manner described, whenever specified in the instructions.



DANGER

1. Before starting a vehicle, always be seated in the driver's seat, place the transmission in neutral, apply the parking brakes, and push in the clutch pedal. Failure to follow these instructions could produce unexpected vehicle movement, which can result in serious personal injury or death. 2. Before working on a vehicle, place the transmission in neutral, set the parking brakes, and block the wheels. Failure to follow these instructions could produce unexpected vehicle movement, which can result in serious personal injury or death.



DANGER

Engine-driven components such as Power Take-Off (PTO) units, fans and fan belts, driveshafts and other related rotating assemblies, can be very dangerous. Do not work on or service engine-driven components unless the engine is shut down. Always keep body parts and loose clothing out of range of these powerful components to prevent serious personal injury. Be aware of PTO engagement or nonengagement status. Always disengage the PTO when not in use.



DANGER

Do not work under a vehicle that is supported only by a hydraulic jack. The hydraulic jack could fail suddenly and unexpectedly, resulting in severe personal injury or death. Always use jackstands of adequate capacity to support the weight of the vehicle.



CAUTION

Before towing the vehicle, place the transmission in neutral and lift the rear wheels off the ground, or disconnect the driveline to avoid damage to the transmission during towing. Volvo Trucks, Inc. cannot anticipate every possible occurrence that may involve a potential hazard. Accidents can be avoided by recognizing potentially hazardous situations and taking necessary precautions. Performing service procedures correctly is critical to technician safety and safe, reliable vehicle operation. The following list of general shop safety practices can help technicians avoid potentially hazardous situations and reduce the risk of personal injury. DO NOT perform any services, maintenance procedures or lubrications until this manual has been read and understood.

4 GENERAL INFORMATION

About the Volvo D13F Engine

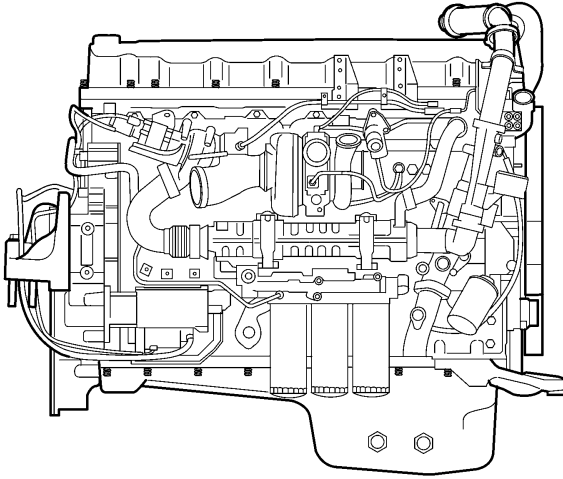

W2005779

The Volvo D13F engine with electronic unit injectors, a cooled Exhaust Gas Recirculation (EGR) system, a Exhaust Aftertreatment System which includes a Diesel Particulate Filter (DPF) and the Holset Variable Geometry Turbocharger (VGT). The Volvo Engine Brake is optional. The engine conforms to year 2007 Environmental Protection Agency (EPA) requirements. The D13F EGR system features reduced restriction plus enhanced efficiency and reliability. Its venturi system is easy to service. A Exhaust Aftertreatment System requires elevated exhaust temperatures. The system uses a diesel oxidation catalyst, a diesel particulate filter and in-line reheating of the exhaust gases. The DPF system removes Particulate Matter (PM) from the exhaust to conform to the 2007 EPA regulations. The Holset VGT features fixed vanes with a sliding nozzle ring. The nozzle position is infinitely variable between open and closed. This design reacts quickly to exhaust pressure and controls inlet pressure more precisely. Reliability is enhanced by having fewer moving parts. Its actuator and bearing housing are water cooled and engine oil lubricated for greater durability. A wide range of the current transmission offerings, including manual, automated manual and automatic, can be teamed with the D13F.

Diagnostic help can be found in the Premium Tech Tool (PTT). To obtain the Tech Tool, contact your local Volvo Dealer. The engine weighs approximately 1160 kg (2560 lb.) dry (with air compressor, without oil, coolant, starter, fan, alternator and clutch). Its design includes a one-piece cylinder head, a single overhead camshaft, three rocker arms per cylinder, unit injectors and no pushrods. Volvo Engine Brake requiring a fourth rocker arm, is optional. Monosteel pistons are made in one piece.



DANGER

Use of ether or similar types of starting aids in Volvo® US07 emission compliant engines is strictly prohibited. This applies to engines with or without the electric pre-heater option. An explosion could occur. Failure to heed this danger may result in severe personal injury or death.

Two optional fan drives are available: On/Off and electronically actuated. The electronically actuated viscous fan drive is precisely controlled by the Engine Electronic Control Unit (EECU).

Timing gears mount on the rear of the D13F improving the flow of cooling air around the front. Special service instructions apply to the camshaft position sensor. The mounting plate, idler and camshaft gears are marked to facilitate proper installation. The air compressor drive gear meshes with the double idler instead of the auxiliary idler as on the MP7 engine. Another feature of the D13F is the rear engine power take-off (REPTO-ready) that is gear driven through the timing gear train. An optional PTO with drive gear, bearing and housing can be added at the factory.

The rocker arm shaft is held in place by camshaft bearing capscrews. There are special instructions for installing the camshaft bearing caps and the rocker arm shaft during service. A stiffener plate fastens to the bottom of the cylinder block to ensure block strength and rigidity. The engine can be used with axle forward or axle back vehicles by virtue of optional oil pans.

The engine fan is mounted high or low depending on vehicle configuration.

The unit injector incorporates the pump, valve and injector. Its internal solenoids permit fast, precise control of fuel delivery into the cylinder. The unit injectors are encased by the valve cover and not exposed to the heat of exhaust system components. Fuel passes through two filters, one of which separates water from the fuel. High-pressure fuel in the unit injectors is created via the rocker arms with roller followers in constant, direct contact with the cams. Replacing injectors requires a specific procedure, and installation requires that the EECU be programmed to recognize replacement injectors. Cleaning injector bores requires a special tool. An engine compression brake option on the D13F engine assists deceleration and braking. The operation of the brake differs from earlier engine models. Working in conjunction with the exhaust cycle, the brake requires a camshaft with four cams per cylinder, two rocker arms for the exhaust valve, a bridge over the two exhaust valves, an electronic control valve and a wiring harness that includes the control valve. The exhaust valves are adjusted with shims Unique colors and the appearance of the valve cover, filters and logo labels distinguish the D13F from other engines in the Volvo line. Preventive maintenance is important to get the most from the Volvo D13F engine and to ensure many years of reliable, trouble-free operation.

There are restrictions concerning the reuse of certain fasteners.

6 GENERAL INFORMATION

D13F Engine Model Identification

Engine Information Plate

IMPORTANT ENGINE INFORMATION				VALVE LASH (JEU SOUPAPES)	
RENSEIGNEMENTS IMPORTANTS MOTEUR				INLET ROCKER 2 mm ADMISSION CULBUTEUR	
ENGINE FAMILY: FAMILLE DE MOTEURS:	ENGINE MODEL: MODELE MOTEUR:	SERIAL NO.:		EXHAUST ROCKER 1.0 mm ECHAPPEMENT CULBUTEUR	
DISPLACEMENT CYLINDREE	ADVERTISED HP @ RPM PUISS. MAXI	FUEL RATE @ ADVERTISED HP PUISS. MAXI	IDLE SPEED RALENTI	ENGINE BRAKE	EXHAUST BRAKE 3.6 mm FREIN SUR ECHAPPEMENT
mm ³ /STROKE mm ³ /COUP					NOx FEL NOx FNE (g/Bhp-hr)
THIS ENGINE CONFORMS TO U.S. EPA AND CALIFORNIA REGULATIONS APPLICABLE TO 2007 MODEL YEAR NEW HEAVY-DUTY ENGINES AND HAS A PRIMARY INTENDED SERVICE APPLICATION AS A HEAVY HEAVY-DUTY DIESEL ENGINE					NMHC+NOx FEL 1.3 NMHC+NOx FNE (g/Bhp-hr)
ment, des ?ats-Unis applicables aux nouveaux moteurs diesel Heavy duty (Gamme lourde) mod? 2007.					PARTICULATE FEL PARTICULAIRE FNE (g/Bhp-hr)
EXHAUST EMISSION CONTROL SYSTEM DISPOSITIF ANTI-POLLUTANT					
EM, EC, TC, CAC, DI, EGR, DPF		THIS ENGINE IS CERTIFIED TO OPERATE ON ULTRA LOW SULFUR DIESEL FUEL ONLY.			

W2033292

The engine information plate is located on the top of the cylinder head (valve) cover. This plate includes information in English and French concerning the following items.

- Engine family, model and serial number
- Displacement, horsepower, fuel rate, idle speed and engine brake
- Emissions regulations to which the engine conforms and other pertinent information required by emissions regulations
- Valve lash settings for inlet, exhaust and engine brake
- NOx, NMHC+NOx and particulate matter emissions
- Exhaust emission control systems

A statement concerning the limitation on the fuel to be used in the engine also appears. Code letters under Exhaust Emission Control Systems represent basic engine systems that impact emissions. They are taken from the following list.

- CAC — Charge Air Cooler
- DI — Direct Injection
- DPF — Diesel Particulate Filter
- EC — Engine Control
- EC — Engine Control
- EM — Engine Modification
- TC — Turbocharger

Service At a Glance

Operating Conditions	Highway	Vocational
	Miles / KM / Months / Hours (whichever comes first)	
BASIC SERVICE		
Engine oil and Filter Change EO – O premium Plus or VDS-4 Oil	30,000 Miles / 48,000 KM or 500 Hours	15,000 Miles / 24,000 KM 90 days or 300 hours
Chassis Lubrication	15,000 Miles / 24,000 KM or 250 Hours	8,000 Miles / 12,000 KM 45 Days or 150 Hours
Custom PM Schedule		
“A” Service (Industry norm or customer specific)	15,000 Miles / 24,000 KM or 250 Hours	8,000 Miles / 12,000 KM 45 Days or 150 Hours
“B” Service (Industry norm or customer specific)	30,000 Miles / 48,000 KM or 500 Hours	15,000 Miles / 24,000 KM 90 days or 300 Hours
3 Axle Alignment	Annually (minimum)	
Gear Oil Change	250,000 Miles / 402,000 KM or 2 years **	40,000 Miles / 64,000 KM 1 year or 1200 Hours **
Engine Components		
Fuel Filter & Water Separator	Every Oil Change	
Air Filter	At Maintenance Indicator or 12 Months	
Coolant (standard)	30,000 Miles 500,000 KM or 500,000 KM or 24 Months	
Coolant Filter (standard)	50,000 Miles / 80,000KM or 6 Months	
Coolant Conditioning	Nitrite Level Must Be Maintained as per Manufactures’s Specification	
Coolant (extended Life) Change	600,000 Miles / 1,000,000 KM or 48 Months	

8 GENERAL INFORMATION

Operating Conditions	Highway	Vocational
Coolant Filter (extended Life) Change	150,000 Miles / 240,000 KM or 12Months	
Power Steering: Fluid / Filter	Annually	Bi-Annually
Initial Valve Adjustment Valve / Injector: Check and Adjust	125,000 Miles / 200,000 KM or 24 Months After initial adjustment: 250,000 Miles / 400,000 KM or 24 Months	
EGR Cooler Damper	120,000 Miles / 200,000 KM or annually	60,000 Miles / 96,000 KM or annually
Drive Belt	300,000 Miles / 500,000 KM (Vocational 12 months)	
Volvo PM Schedule		
“L” Chassis Lube	15,000 Miles / 24,000 KM or 250 Hours	8,000 Miles / 12,000 KM or 150 Hours
“A” Inspection	15,000 Miles / 24,000 KM or 250 Hours	8,000 Miles / 12,000 KM or 150 Hours
“B” Inspection	30,000 Miles / 48,000 KM or 500 Hours	15,000 Miles / 24,000 KM or 300 Hours
“C” Inspection	60,000 Miles / 96,000 KM or 1000 Hours	30,000 Miles / 48,000 KM or 600 Hours
“D” Inspection	120,000 Miles / 200,000 KM or 2000 Hours	60,000 Miles / 96,000 KM or 1200 Hours
<p>Genuine Volvo Filters are strongly recommended. *Certain chassis vocations may require more frequent service intervals. Alter the maintenance programs to meet your needs, but never exceed Volvo recommended intervals.</p> <p>**See vehicle maintenance and lubrication manual specific details.</p> <p>THIS INSPECTION FORM IS ONLY A GENERAL GUIDE. PLEASE REFER TO THE APPROPRIATE MAINTENANCE AND LUBRICATION MANUAL FOR YOUR SPECIFIC VEHICLES AS THE AUTHORITATIVE SOURCE FOR ALL DETAILS OF A PROPER AND COMPLETE INSPECTION AND MAINTENANCE PLAN FOR YOUR VEHICLE.</p>		

Service Precautions Summary

Following is a summary list of the DO and Don't issues applying to D13F engine service:

- 1 **DO NOT** machine the cylinder head for clean-up since this will change injector depth, thereby affecting emission. It will also upset the ability to correctly adjust timing gear backlash.
- 2 **DO NOT** grind the injector copper sleeves.
- 3 Connecting rods and crankshaft main bearing capscrews can be re-used **four** times. Screw heads **MUST** be punch marked at each overhaul to indicate the number of times used.
- 4 Install the crankshaft main bearing caps according to marked assembly number. Correct alignment is also critical and is aided by the following:
 - Two casting nipples, located in the cylinder block and on the respective bearing cap, eliminate incorrect assembly
 - Sleeve pressed into the cylinder block guide the bearing caps into position for proper alignment
- 5 Connecting rod caps **MUST BE** mated to their respective connecting rods due to the "fractured manufacturing" process used. Also, the rod caps can be installed only one way because of the difference in spacing between screw holes at each side of the cap.
- 6 **DO NOT** use the lifting eye on the flywheel housing when tilting the engine / transmission assembly to an angle greater than 15 degrees.
- 7 Cylinder head installation requires lowering the head onto the gasket, then pulling the head horizontally against the timing gear mounting plate using through screws. Pressed bosses in the gasket keep the head from making full contact with the gasket surface and prevent damage to the rubber sealing rings as the head slides into position.
- 8 **DO NOT** use starting fluid (ether) on engine equipped with an inlet manifold air heater element. An explosion could occur.
- 9 The D13F engine uses a number of O-rings for sealing various fluid joints and tubes. It is essential that **new** O-rings of the correct material be used whenever joints are disassembled and reassembled.

10 GENERAL INFORMATION

Engine Serial Number Identification

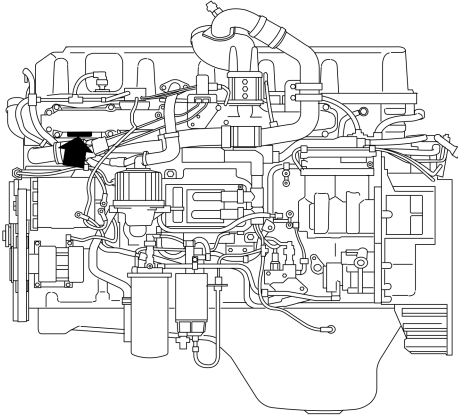

W2033586

In addition to the engine information plate on the cylinder head cover, the engine is also identified by the engine serial number stamped into the cylinder block. This serial number is located on the block left side at the front just below the inlet manifold.

Engine Specification

Weights and Dimensions

Item	Specification
Engine type	In-line direct injection diesel
Number of cylinders	6
Displacement	13 L
Swept volume	12.78 L
Cylinder bore and stroke	131 x 158 mm (5.16 x 6.22 inches)
Emissions level	EPA 07 (2.5g NOx; 0.1g Pt) maximum
Fuel system	Electronic unit injector
Valve actuation	Single overhead camshaft, four valves per cylinder
Aspiration	Variable geometry turbocharger with sliding nozzle ring
Cylinder and piston type	Wet Sleeve; one-piece steel piston
Electronic control	Electronic management system
Emission controls	Cooled EGR; Diesel Particulate Filter (DPF)
Peak power ratings	335–485 hp
Peak torque ratings	1830–2237 Nm (1350–1650 ft-lb)
Low idling	10 rps (600 rpm)
Fast idling	35.8 rps (2150 rpm)
Maximum full load revolutions	31.7 rps (1900 rpm)
Weight (production engine without vehicle details) (production engine with vehicle details)	1,115 kg (2456 lb) 1,143 kg (2518 lb)
Firing order	1-5-3-6-2-4
Compression ratio	16:1
Fasteners and threads	Metric
Flywheel housing (standard)	Aluminum
Total length	1366 mm (54 inches)
Total width	971 mm (38 inches)
Total height	1281 mm (50 inches)

12 SPECIFICATIONS

Engine Performance Specification

Engine Designation	Horsepower	@RPM	Torque (Maximum)	@RPM
D13F335	250 kW (335 hp)	1400 – 1700	1830 Nm (1350 ft-lb)	1100
D13F375	280 kW (375 hp)	1400 – 1700	1966 Nm (1450 ft-lb)	1100
D13F405	302 kW (405 hp)	1500 – 1700	1966 Nm (1450 ft-lb)	1100
D13F425	317 kW (425 hp)	1500 – 1600	2102 Nm (1550 ft-lb)	1100
D13F435	324 kW (435 hp)	1400 – 1800	2237 Nm (1650 ft-lb)	1100
D13F485	362 kW (485 hp)	1600 – 1900	2237 Nm (1650 ft-lb)	1100

Component Features and Materials

Item	Description
Air compressor	Flange mounted, oil lubricated, water cooled
Camshaft	Induction hardened, gear driven
Coolant conditioner	Spin-on type, disposable
Connecting rods	Forged steel, cracked cap design
Crankshaft	Drop forged steel, induction hardened, seven main bearings
Cylinder block	In-line six cylinder, nodular iron, machined with bearing caps, stiffener plate, timing gear mounting plate, guide dowels for cylinder head; wet replaceable cylinder sleeves
Cylinder head	One-piece cast iron alloy; overhead camshaft, four valves per cylinder, unit injectors; cast iron valve guides and oil seals; steel valve seats; valve alignment 12 degrees from perpendicular; copper injector sleeves; integral fuel passages and thermostat housing; guide slots for installation on block
Valve cover	Plastic, 20 spring tension screws
Cylinder liner	Wet Sleeve; replaceable; with EDPM rubber and Viton seals
Cylinder head — Valve springs	Double springs on each exhaust valve
Cylinder head — Valve guides	Cast iron, replaceable; with oil seals
Cylinder head gasket	One-piece steel stamping; elastomer seals added; one-time bosses to aid in head installation
Cylinder head bolts	M16 (38)
Timing gear cover (rear of cylinder head)	Die-cast aluminum, elastomer seals
Flywheel housing	Die-cast aluminum
Fuel filters	One main, one pre-filter

14 SPECIFICATIONS

Component Features and Materials

Item	Description
Fuel injection	Six individually programmed unit injectors: EECU controlled; common fuel gallery in head; constant supply pressure; over-pressure return
Fuel supply pump	Gear type pump integral with power steering pump; idler gear driven
Lubrication system	Crankshaft gear driven oil pump; system integrated with block and head; serves camshaft, rocker arm shaft, pistons, crankshaft, air compressor, turbocharger, EGR valve; three oil filters; oil level and temperature sensor in oil pan; pump pressure tube, strainer and pressure relief valve
Main bearing caps	Nodular iron; machined with block; No. 7 mounts oil pump; numbered for reassembly; sleeve guides for screws; thrust washers at No. 4 main bearing journal
Exhaust manifold	Three-piece, six port
Pistons	One-piece steel; three ring grooves
Piston rings — Compression	Two: one trapezoidal cross section, one rectangular cross section
Piston rings — Oil	One: garter spring type; scraping
Oil filters	Two full flow, one bypass; Filter capacity, two full flow: <ul style="list-style-type: none"><li data-bbox="505 1096 838 1125">• 4.0–4.5 liters (4.2–4.8 quarts)
Oil pan	Plastic, steel; 22 spring tension screws Sump capacity: <ul style="list-style-type: none"><li data-bbox="505 1206 859 1235">• 25 liters (26.4 quarts) minimum<li data-bbox="505 1243 866 1273">• 30 liters (31.7 quarts) maximum
Thermostat	Sleeve type: 82°C (180°F)
Thermostat housing	Integrated in cylinder head

Component Features and Materials

Item	Description
Turbocharger	Variable geometry type: Holset; exhaust driven; fixed vanes; sliding ring nozzle; infinitely variable volume; oil and water cooled
Valve lifters	Roller followers
Valve seat inserts	Pressed in head; replaceable
Vibration damper	Internal fluid-filled ring
Coolant pump	Centrifugal rotor impeller; belt driven

16 SPECIFICATIONS

Tightening Torques and Patterns

Sensors and Wiring Harness



CAUTION

Overtorquing a sensor or sensor mounting screw can result in sensor breakage or thread damage

Sensors	
Air Pressure / Temperature, Inlet Manifold	3.3 N.m (29 lb-in)
Camshaft Position	8 ± 2 N.m (6 ± 1 lb-ft)
Coolant Level (surge tank)	Plug-in
Coolant Temperature (front, right side of cylinder head)	22 ± 3 N.m (16 ± 2 lb-ft)
Crankcase Position / Engine Speed	10 ± 1 N.m (7 ± 1 lb-ft)
Crankcase Pressure (block, front of air compressor)	30 ± 5 N.m (22 ± 4 lb-ft)
Fuel Pressure ((fuel filter housing)	25 ± 3 N.m (18.5 ± 2 lb-ft)
Oil Level / Temperature, (inside sump)	standard torque
Oil Pressure (block, front of air compressor)	30 ± 5 N.m (22 ± 4 lb-ft)
Turbocharger Wheel Speed	8.5 N.m (75 lb-in)
Water -in-Fuel (on Fuel / Water Separator)	1.7 ± 10.6 N.m (15 ± 5 lb-in)
Wiring Harness	
Attaching Screws	24 ± 4 N.m (18 ± 3 lb-ft)

General Tightening Torques

M6 standard bolt 8.8	$10 \pm 1.5 \text{ Nm}$ ($7.4 \pm 1 \text{ ft-lb}$) ($89 \pm 13 \text{ in-lb}$)
M8 standard bolt 8.8	$24 \pm 4 \text{ Nm}$ ($18 \pm 3 \text{ ft-lb}$)
M10 standard bolt 8.8	$48 \pm 8 \text{ Nm}$ ($35 \pm 6 \text{ ft-lb}$)
M12 standard bolt 8.8	$85 \pm 15 \text{ Nm}$ ($63 \pm 11 \text{ ft-lb}$)
M14 standard bolt 8.8	$140 \pm 25 \text{ Nm}$ ($103 \pm 18 \text{ ft-lb}$)
M16 standard bolt 8.8	$190 \pm 35 \text{ Nm}$ ($140 \pm 26 \text{ ft-lb}$)

General Tightening Torques

Bolts that have been torque-tightened only, can be reused.	
Torque-tightened bolts, angle-tightened bolts, or yield-limit-tightened bolts:	
Grade 8.8	Should not be reused
Grade 10.9	Can be reused
Grade 12.9	Can be reused
Note: Check bolts before reusing. Bolts showing damage, for example cut marks on the underside or distortion of the flats, should be discarded.	

General Tightening Torques

Intermediate front engine mounting brackets (accessories brackets)	
Step 1	$105 \pm 15 \text{ Nm}$ ($77.5 \pm 11 \text{ ft-lb}$)
Step 2 (angle tightening)	$60 \pm 5 \text{ degrees}$
Front engine mounting	
Bracket to engine block	$275 \pm 45 \text{ Nm}$ ($203 \pm 33 \text{ ft-lb}$)
Bracket to engine cushion	$140 \pm 25 \text{ Nm}$ ($103 \pm 18 \text{ ft-lb}$)
Cushion to cross member	$85 \pm 15 \text{ Nm}$ ($63 \pm 11 \text{ ft-lb}$)

18 SPECIFICATIONS

General Tightening Torques

Rear engine mounting	
Bracket to flywheel housing	300 ± 45 Nm (221 ± 33 ft-lb)
Bracket to engine cushion	540 ± 90 Nm (398 ± 66 ft-lb)
Cushion to frame	200 ± 30 Nm (148 ± 24 ft-lb)
Crankshaft main bearing cap	
Step 1	150 ± 20 Nm (111 ± 15 ft-lb)
Step 2 (angle tightening)	120 ± 5 degrees
Connecting rod cap	
Step 1	20 ± 3 Nm (15 ± 2 ft-lb)
Step 2	60 ± 3 Nm (44 ± 2 ft-lb)
Step 3 (angle tightening)	90 ± 5 degrees
Piston cooling nozzle	24 ± 4 Nm (18 ± 3 ft-lb)
Engine block plugs	50 ± 5 Nm (37 ± 7 ft-lb)

Engine Stiffening Frame

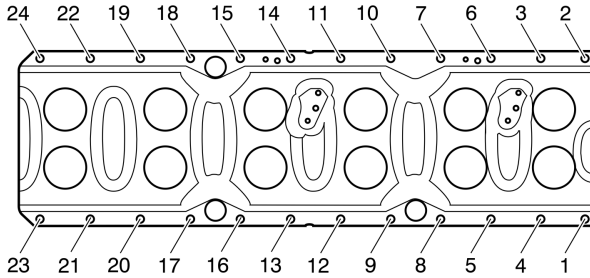

T2022728

Step 1: Tighten the bolts 1-24 in numerical order 40 ± 5 Nm (30 ± 4 ft-lb)

Step 2: Tighten the bolts 1-24 in numerical order (angle tightening) 90 ± 5 degrees

Note: These bolts should not be reused.

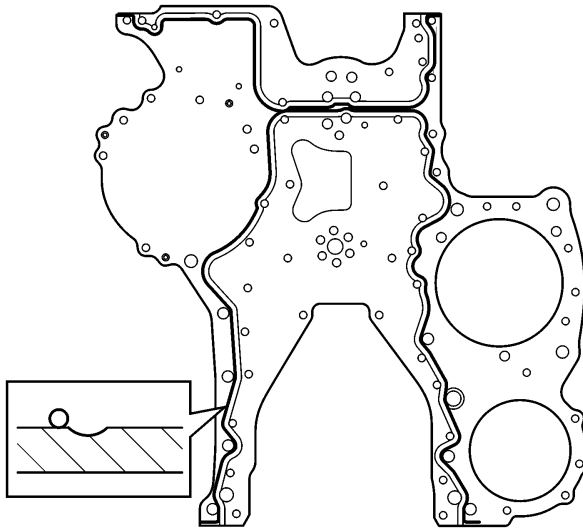

T2022337

Note: Apply sealant outside the groove as illustrated, maximum 20 minutes before mounting.

Thickness of sealant bead: 2 mm (0.079 inch)

20 SPECIFICATIONS

Timing Gear Gasket

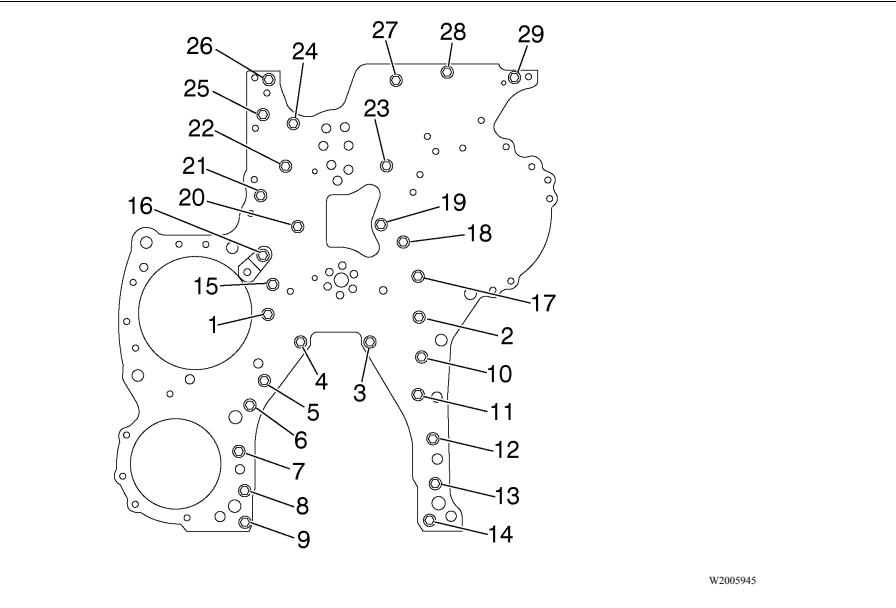

W2005945

Do not reuse mounting plate screws.
Do NOT apply sealant to new, coated screws.
Timing gear plate, tighten in sequence shown
 28 ± 4 Nm (21 ± 3 ft-lb)

Timing Gears

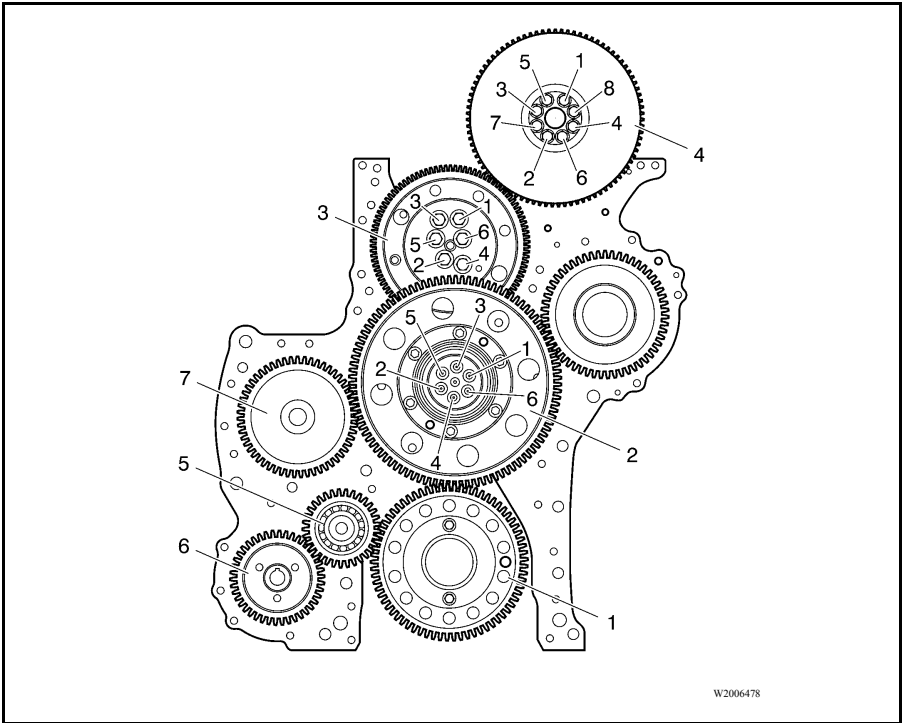

1. Drive gear, crankshaft.....	24 ± 4 Nm (18 ± 3 ft-lb)
2. Double idler gear:	
Step 1	25 ± 3 Nm (19 ± 2 ft-lb)
Step 2 (angle tightening).....	110 ± 5 degrees
Note: Tighten following the order shown in the illustration.	
3. Idler gear, adjustable:	
Step 1	35 ± 4 Nm (26 ± 3 ft-lb)
Step 2 (angle tightening).....	120 ± 5 degrees
Note: Tighten following the order shown in the illustration.	
4. Drive gear, camshaft (includes vibration damper):	
Step 1	45 ± 5 Nm (33 ± 4 ft-lb)
Step 2 (angle tightening).....	90 ± 5 degrees
Note: Tighten following the order shown in the illustration.	
5. Idler gear: 140 ± 10 Nm (103 ± 7 ft-lb)	
6. Drive gear, power steering pump: 100 ± 10 Nm (74 ± 7 ft-lb)	
7. Drive gear, air compressor: 200 +50 -0 Nm (147 +37 -0 ft-lb)	

22 SPECIFICATIONS

Flywheel Housing

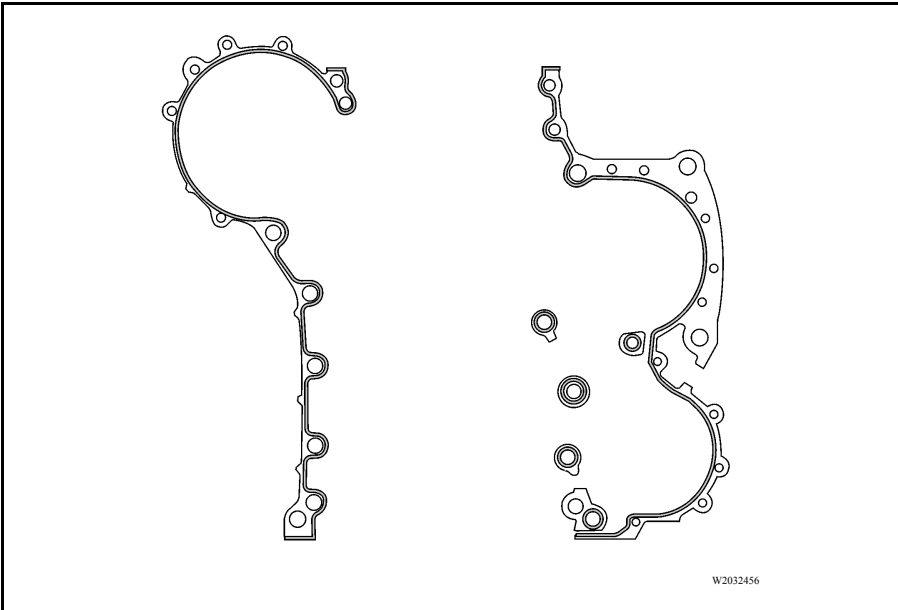

W2032456

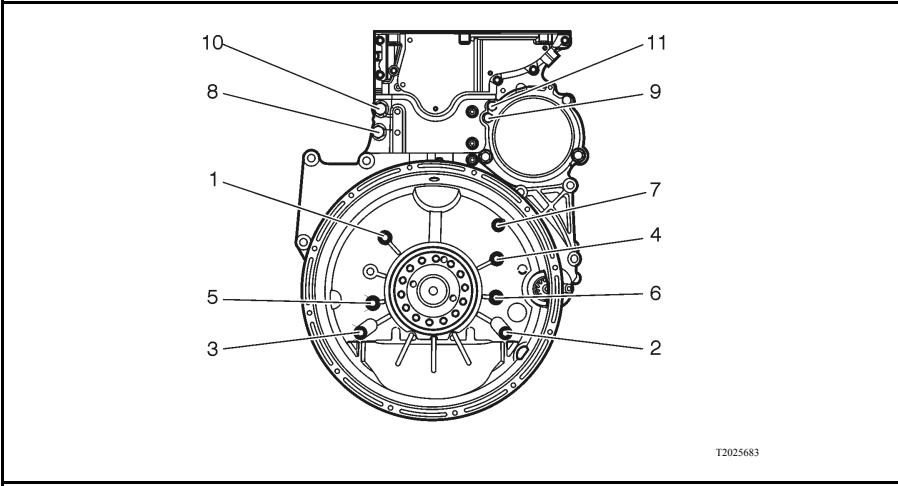

T2025683

- Step 1: Tighten all M14, M10, M8 bolts24 ± 4 Nm (18 ± 3 ft-lb)
- Step 2: Tighten all bolts in numerical order to the following torque:
- M14 bolts (1–7) 140 ± 20 Nm (103 ± 15 ft-lb)
- M10 bolts (8–11).....48 ± 8 Nm (36 ± 6 ft-lb)
- M8 bolts (12–22)24 ± 4 Nm (18 ± 3 ft-lb)

Note: Apply sealant in a 2 mm (0.079 inch) thick bead as illustrated.

Timing Gear Cover

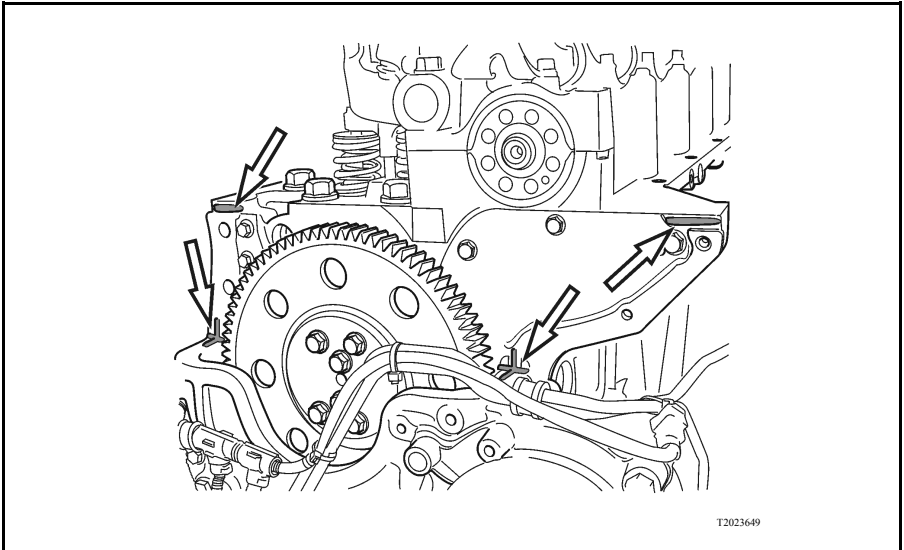

T2023649

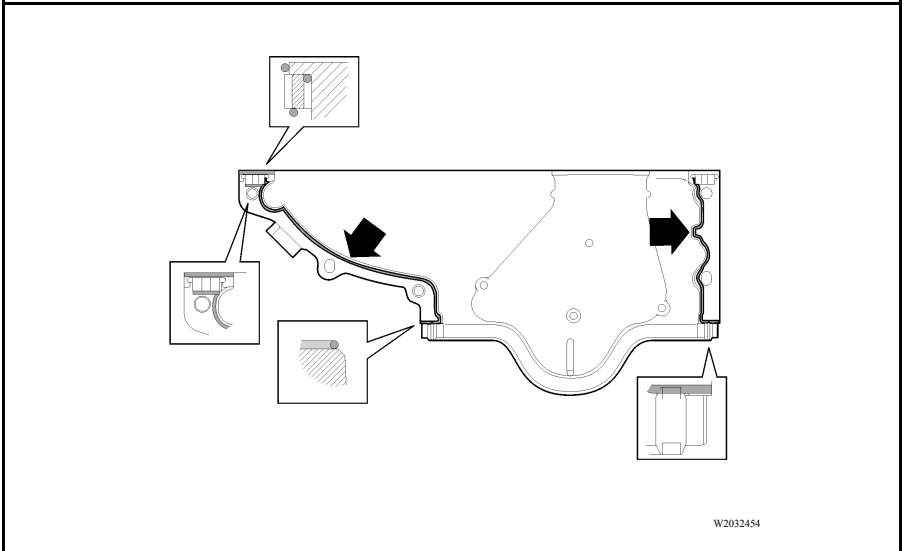

W2032454

- Step 1: Position the cover in place with bolts 1 and 2 and install alignment tool.
 Step 2: Tighten the bolts in the numerical order shown.24 ± 4 Nm (18 ± 3 ft-lb)

Note: Apply sealant in a 2 mm (0.079 inch) thick bead, maximum 20 minutes before mounting, and carefully tighten the contact surfaces shown in the enlarged parts of the illustration.

24 SPECIFICATIONS

Flywheel

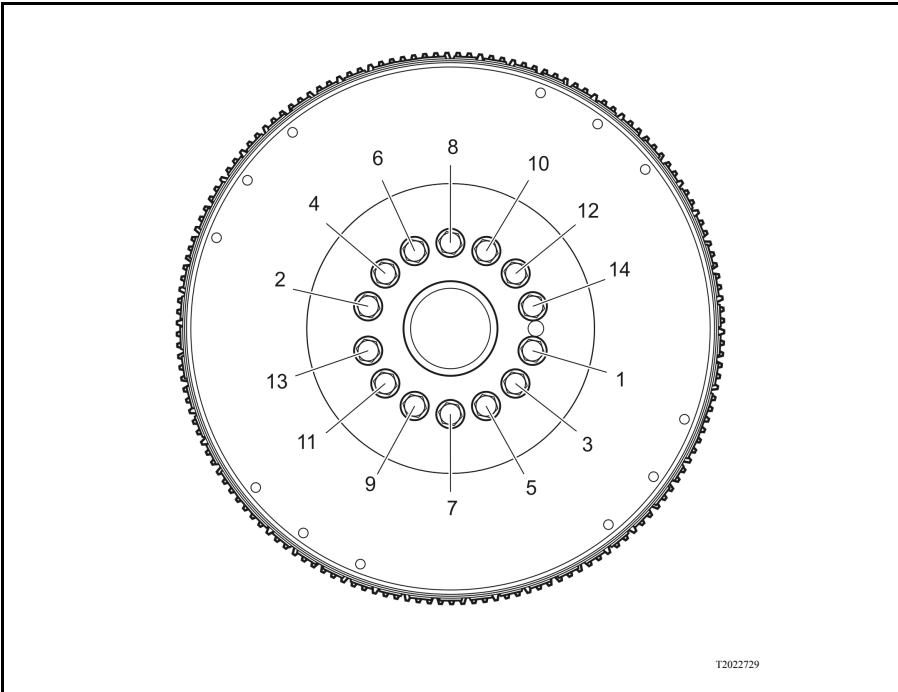

T2022729

- Step 1 $60 \pm 5 \text{ Nm}$ ($44 \pm 4 \text{ ft-lb}$)
- Step 2 (angle tightening) $120 \pm 10 \text{ degrees}$

Note: Make sure the flange is dry and clean. Tighten the bolts in the numerical order as shown. Mark the head of each screw after installation. Discard screws with four marks when removed and replace with **newscrews**.

Do not lubricate new screws that are coated.

Cover, Crankshaft Sseal

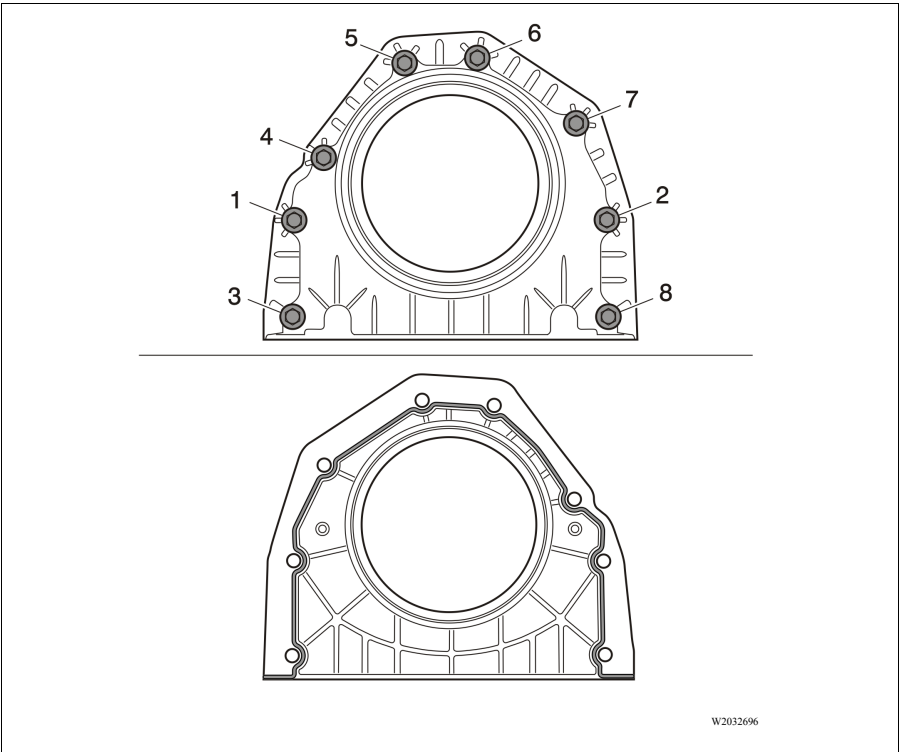

W2032696

Step 1. Position the cover with bolts 1 and 2 and tighten to contact

Step 2: Tighten the bolts in numerical order 1–8 as shown..... $24 \pm 4 \text{ Nm}$ ($18 \pm 3 \text{ ft-lb}$)

Note: Apply sealant in a 2 mm (0.079 inch) thick bead as illustrated and tighten bolts in numerical order.

26 SPECIFICATIONS

Front Engine Support

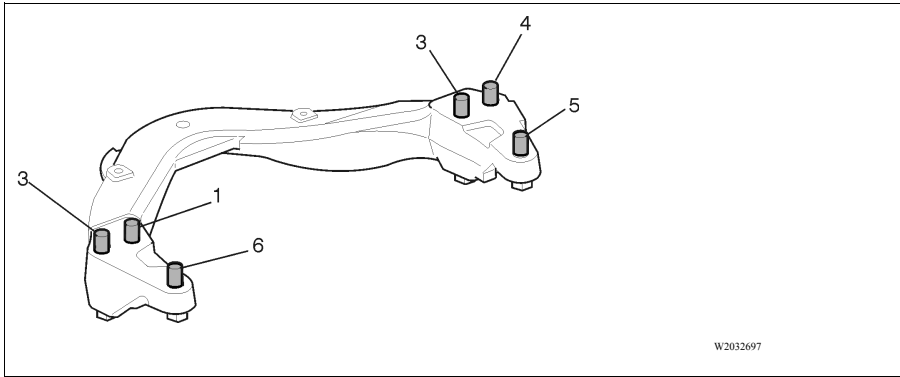

Step 1. Tighten in order: 1, 2, 3, 4, 5 and 6. 275 ± 45 Nm (203 ± 33 lb-ft)
 Step 2. Verify in the same order. 275 ± 45 Nm (203 ± 33 lb-ft)

Front Engine Support Mounting Bracket

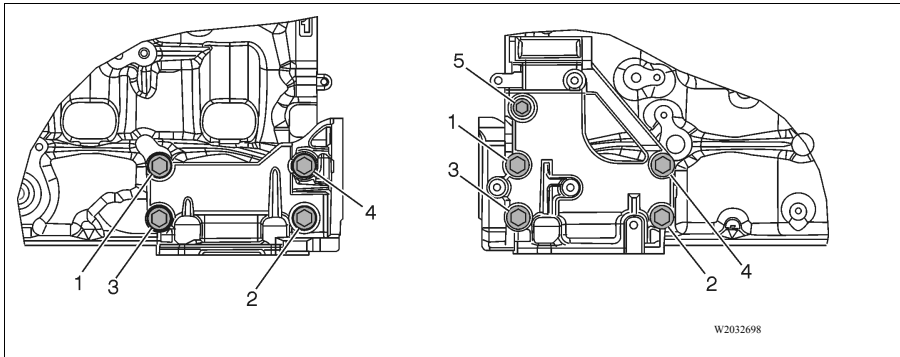

Sequence	Torque	Angle Tighten
Step 1. Screw No. 1	80 ± 15 Nm (59 ± 11 lb-ft)	—
Step 2. Screw No. 2, 3 and 4	105 ± 15 Nm (77 ± 11 lb-ft)	$60 \pm 5^\circ$
Step 3. Screw No. 1	105 ± 15 Nm (77 ± 11 lb-ft)	$60 \pm 5^\circ$
Step 4. Screw No. 5	Standard screw torque	—

Crankshaft Vibration Damper

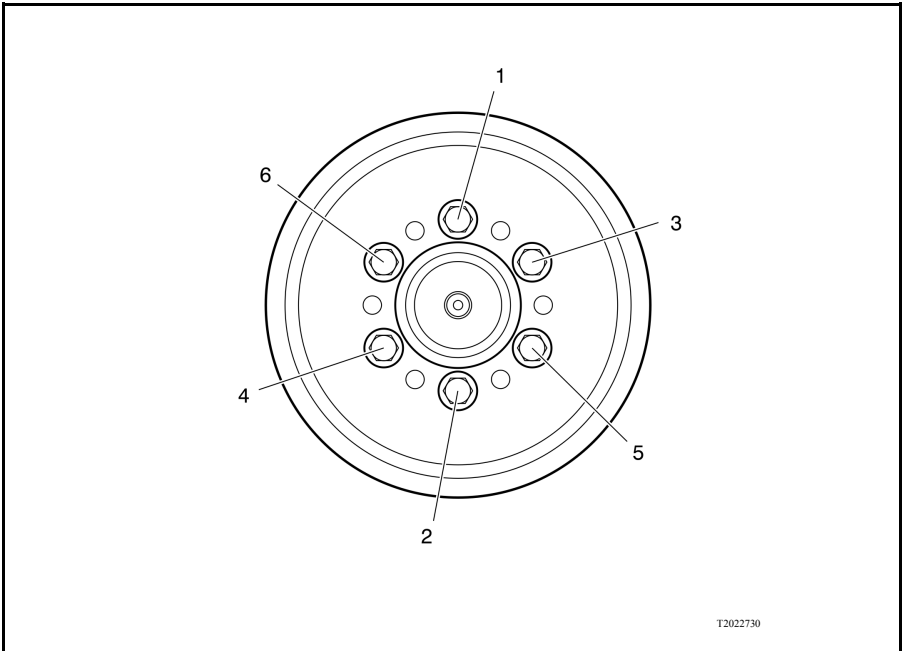

T2022730

- | | |
|--------------|---------------------------|
| Step 1 | 35 ± 5 Nm (26 ± 4 ft-lb) |
| Step 2 | 90 ± 10 Nm (66 ± 7 ft-lb) |

Note: Tighten the bolts in the numerical order 1, 2, 3, 4, 5, 6, 1.
 The vibration damper 8.8 bolts should not be reused.

28 SPECIFICATIONS

Cylinder Head

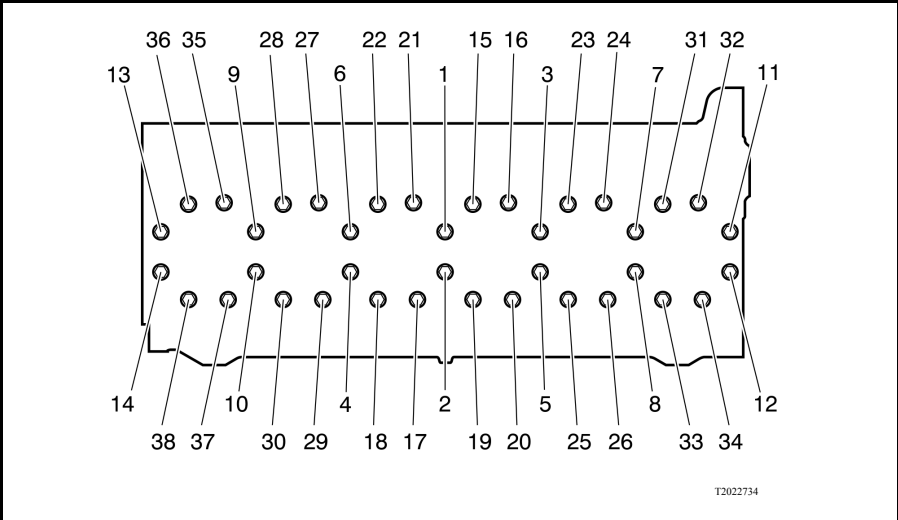

T2022734

- Step 1 $100 \pm 5 \text{ Nm}$ ($74 \pm 4 \text{ ft-lb}$)
- Step 2 (angle tightening)..... $120 \pm 5 \text{ degrees}$
- Step 3 (angle tightening)..... $90 \pm 5 \text{ degrees}$

Note: The cylinder head must be mounted according to instructions, see Cylinder Head, Replacement.

Bearing Cap, Camshaft/Rocker Arm Shaft

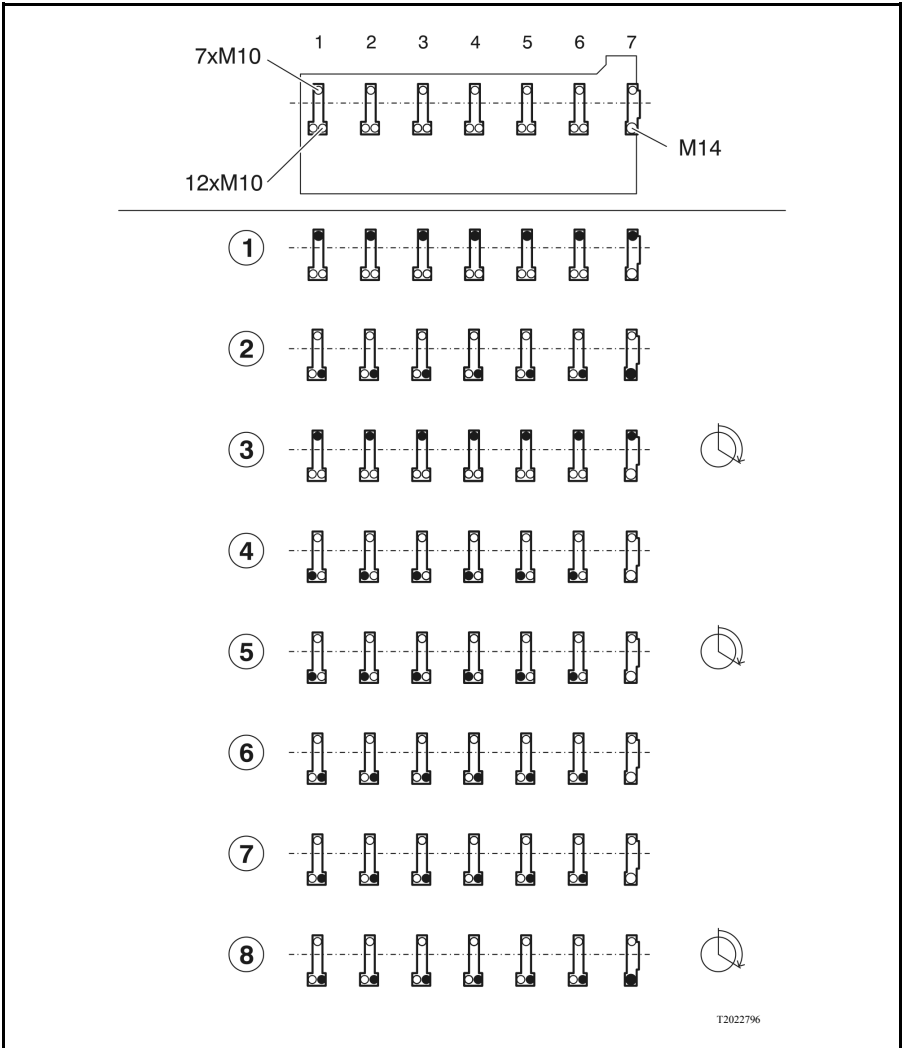

30 SPECIFICATIONS

Bearing caps 1 to 6 are attached with one bolt on the engine right side and two bolts on the engine left side, while bearing cap 7 is attached with only one bolt per side. Tighten the bolts in the following steps as illustrated:

Note: Tighten the bolts in numerical order from bearing cap 1 to 7 or 7 to 1, except in step 2.

Step 1: With camshaft and bearing caps in place, tighten the marked bolts of bearing caps 1 to 7 25 ± 3 Nm (19 ± 2 ft-lb)

Step 2: With rocker shaft in place, tighten the marked bolts (in stages) in the order 4, 3, 5, 2, 6, 1, 7..... 60 ± 5 Nm (44 ± 4 ft-lb)

Note: The bolts must be tightened in stages to ensure that the rocker arm shaft is seated without bending.

Step 3: Angle tighten marked bolts of bearing caps 1 to 7..... 90 ± 5 degrees

Step 4: Tighten the marked bolts of bearing caps 1 to 6 25 ± 3 Nm (19 ± 2 ft-lb)

Step 5: Angle tighten the bolts of bearing caps 1 to 6..... 120 ± 5 degrees

Step 6: Loosen the marked bolts of bearing caps 1 to 6.

Step 7: Tighten the marked bolts of bearing caps 1 to 6 25 ± 3 Nm (19 ± 2 ft-lb)

Step 8: Angle tighten the bolts of bearing caps 1 to 6 and the bolt of bearing cap 7 120 ± 5 degrees

Note: When only the rocker arm has been loosened, step 1 and step 3 are not required.

Volvo Engine Brake control valve 24 ± 4 Nm (18 ± 3 ft-lb)

Locknut, Valve Adjustment Screw

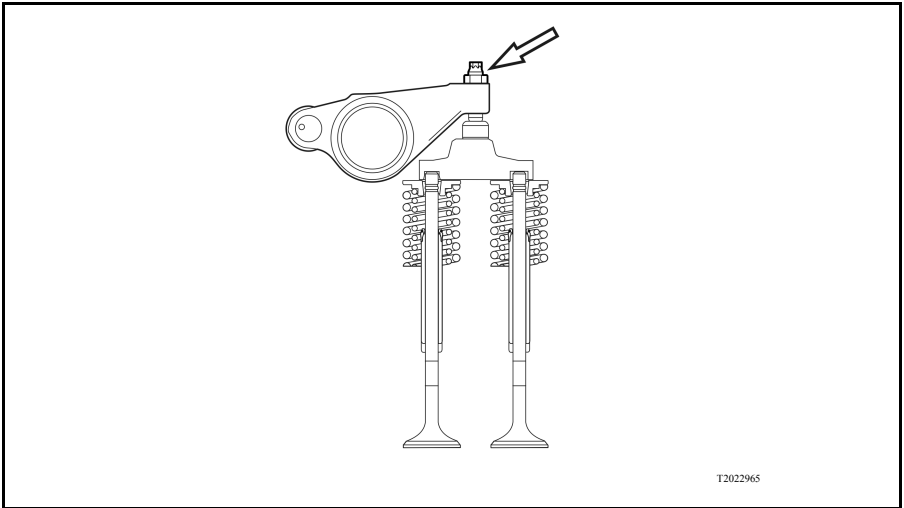

Locknut, valve adjustment screw (inlet/exhaust)	$38 \pm 4 \text{ Nm}$ ($28 \pm 3 \text{ ft-lb}$)
or, angle tighten after contact.....	$60 \pm 5 \text{ degrees}$

Locknut, Valve Adjustment Screw (Volvo Engine Brake)

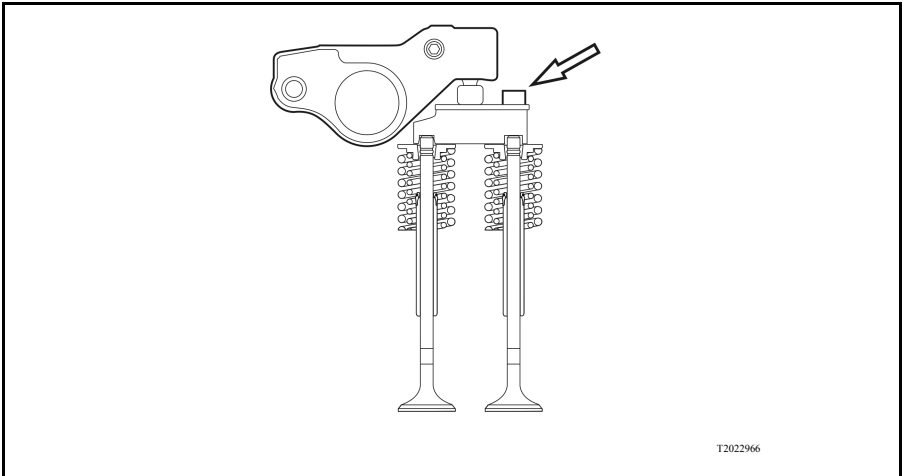

Locknut, valve adjustment screw (exhaust, VEB).....	$38 \pm 4 \text{ Nm}$ ($28 \pm 3 \text{ ft-lb}$)
or, angle tighten after contact.....	$30 +1.5 -0 \text{ degrees}$

Note: Hold the valve bridge while tightening.

32 SPECIFICATIONS

Locknut, Volvo Engine Brake Rocker Arm

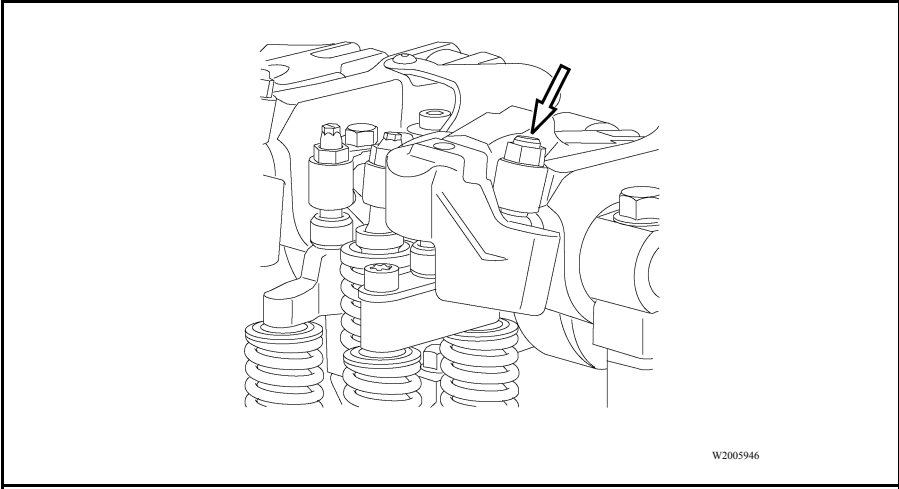

W2005946

Locknut, Volvo Engine Brake rocker arm	$52 \pm 4 \text{ Nm}$ ($38 \pm 3 \text{ ft-lb}$)
or, angle tighten after contact.....	$45 \pm 5 \text{ degrees}$

Camshaft bearing Cap

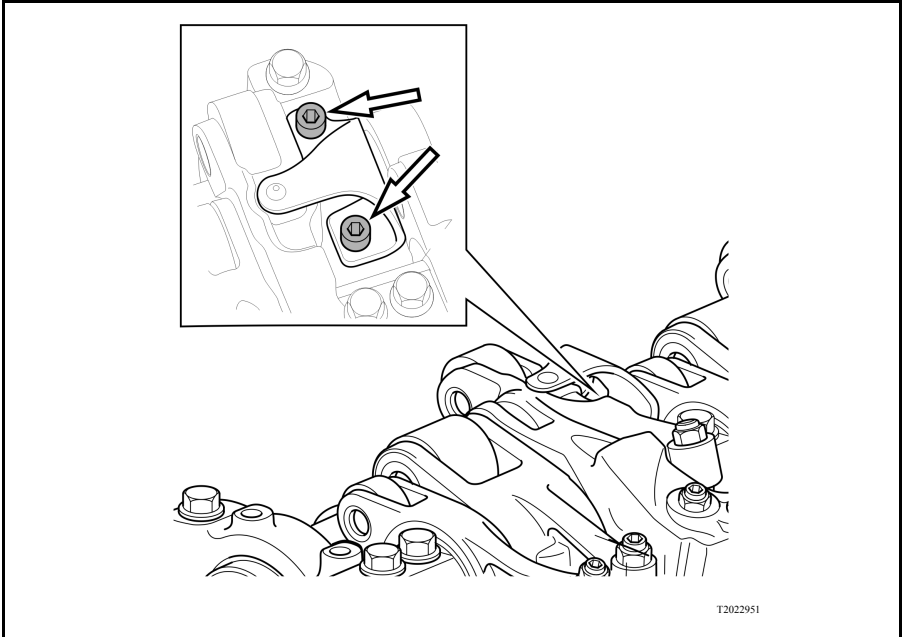

T2022951

Camshaft bearing cap spring tab (Volvo Engine Brake only)
 $25 \pm 3 \text{ Nm}$ ($18 \pm 2 \text{ ft-lb}$)

34 SPECIFICATIONS

Valve Cover

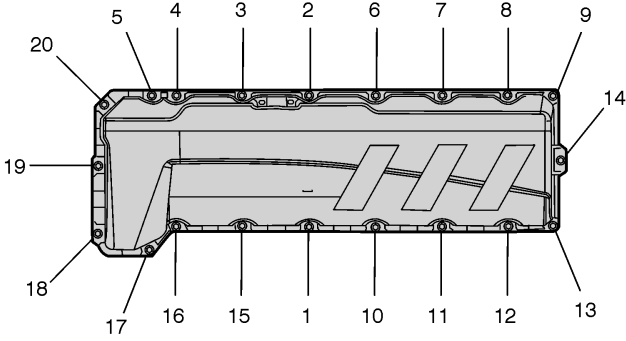

W2032521

Install two alignment pins and bushings in the head before assembling the valve cover.

Note: Tighten the bolts in the numerical order shown, $.24 \pm 4 \text{ Nm}$ ($18 \pm 3 \text{ ft-lb}$)

Oil pump, pickup tube	$.24 \pm 4 \text{ Nm}$ ($18 \pm 3 \text{ ft-lb}$)
-----------------------------	---

Oil filter housing	$.24 \pm 4 \text{ Nm}$ ($18 \pm 3 \text{ ft-lb}$)
--------------------------	---

Oil filter.....	$.25 +5/-0 \text{ Nm}$ ($18.5 +3.5/-0 \text{ ft-lb}$)
-----------------	---

Oil Pan

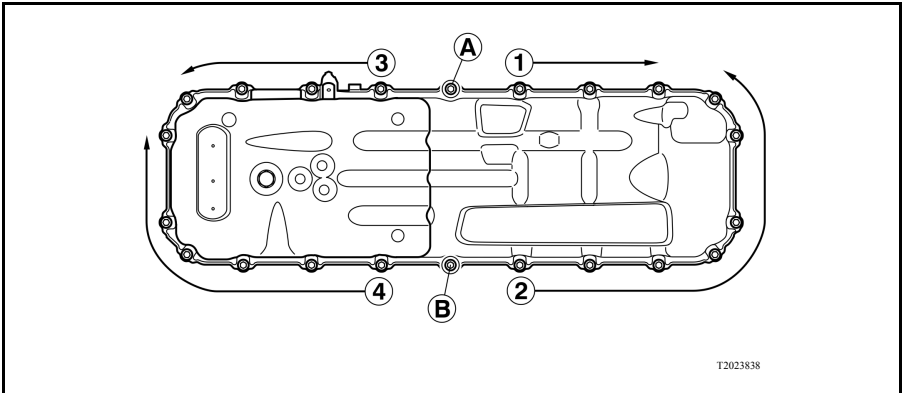

T2023838

Oil pan (steel and plastic)	24 ± 4 Nm (18 ± 3 ft-lb)
Install the oil pan bolts A and B, and tighten.....	24 ± 4 Nm (18 ± 3 ft-lb)
Tighten the bolts from the middle and outwards in order 1-4 as shown	24 ± 4 Nm (18 ± 3 ft-lb)
Finish by checking the torque for bolts A and B	24 ± 4 Nm (18 ± 3 ft-lb)
Drain plug, oil pan (steel and plastic)	60 ± 10 Nm (44 ± 7 ft-lb)

36 SPECIFICATIONS

Additional Bottom Of Engine Components

Lube Valve Housing	
Attaching Screws (4)	Hand start all, then tighten to 48 ± 8 Nm (35 ± 6 lb-ft)
Crankshaft Bearing Caps	
Discard screws with four marks when removed and substitute new screws.	
Step 1. Attaching Screws	150 ± 20 Nm (111 ± 15 lb-ft)
Step 2. Angle tighten	$120^\circ \pm 5^\circ$
Connecting Rod Bearing Caps	
Discard screws with four marks when removed and substitute new screws. Tighten screws in a cross pattern	
Step 1. Attaching Screws	20 ± 3 Nm (15 ± 2 lb-ft)
Step 2.	60 ± 3 Nm (44 ± 2 lb-ft)
Step 3. Angle tighten	$90^\circ \pm 5^\circ$
Oil Pan Drain Plug	60 ± 10 Nm (44 ± 7 lb-ft)
Oil Pump Attaching Screws	24 ± 4 Nm (18 ± 3 lb-ft)
Nozzle Attaching Screws, Piston Cooling Do not reuse	24 ± 4 Nm (18 ± 3 lb-ft)

Oil cooler, retaining bolts

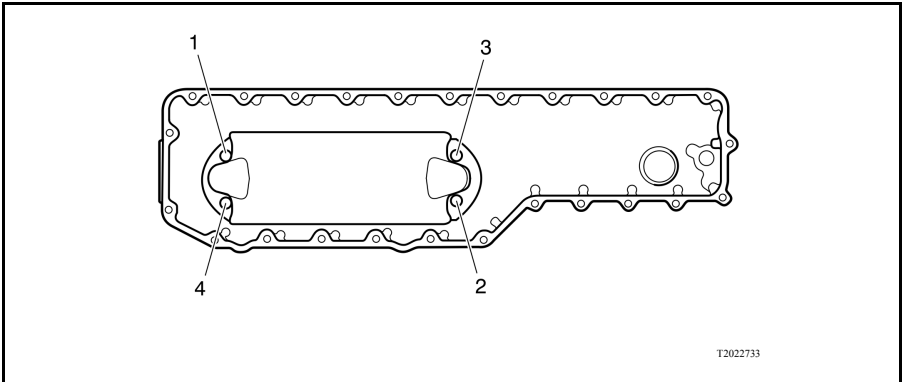

T2022733

- | | |
|--------------|--|
| Step 1 | $5 \pm 1 \text{ Nm}$ ($44 \pm 9 \text{ in-lb}$) |
| Step 2 | $27 \pm 4 \text{ Nm}$ ($20 \pm 3 \text{ ft-lb}$) |

Note: Tighten the bolts diagonally and finish by tightening the first bolt again.

Oil cooler cover

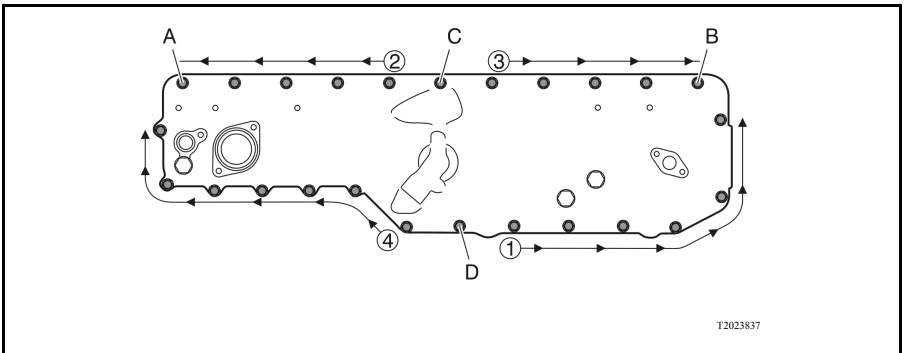

T2023837

Position the cover to the engine block and install bolt (A) into the oval hole. Press the cover against the water pump housing using an assembly tool 88800022 and install bolt (B). Check that the cover is positioned correctly.

- | | |
|---|--|
| Install bolts C and D and tighten | $24 \pm 4 \text{ Nm}$ ($18 \pm 3 \text{ ft-lb}$) |
| Tighten the cover bolts from the middle and outwards in order 1–4 as shown | $24 \pm 4 \text{ Nm}$ ($18 \pm 3 \text{ ft-lb}$) |
| Finish by checking the torque for bolts C and D | $24 \pm 4 \text{ Nm}$ ($18 \pm 3 \text{ ft-lb}$) |

38 SPECIFICATIONS

Retainer, Unit Injector

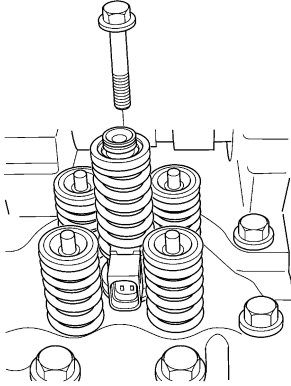

T2022208

Retainer, unit injector: This tightening method is for a unit injector with a sealing washer.

First tightening:

Step 120 +5/-0 Nm (15 +4/-0 ft-lb)

Step 2. Angle tightening 180 ± 5 degrees

Loosen until the torque is 10–15 Nm (7–11 ft-lb).

Second tightening:

Step 120 +5/-0 Nm (15 +4/-0 ft-lb)

Step 2. Angle tightening 90 ± 5 degrees

Locknut, Unit Injector Adjusting Screw

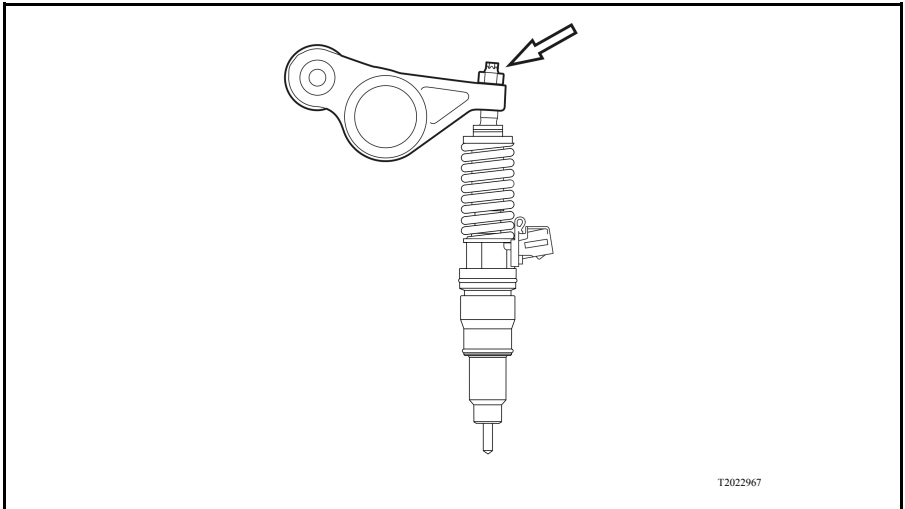

T2022967

Locknut, unit injector adjusting screw.....	$52 \pm 4 \text{ Nm}$ ($38 \pm 3 \text{ ft-lb}$)
or, angle tighten after contact.....	$45 \pm 5 \text{ degrees}$

40 SPECIFICATIONS

Low Pressure Fuel Circuit

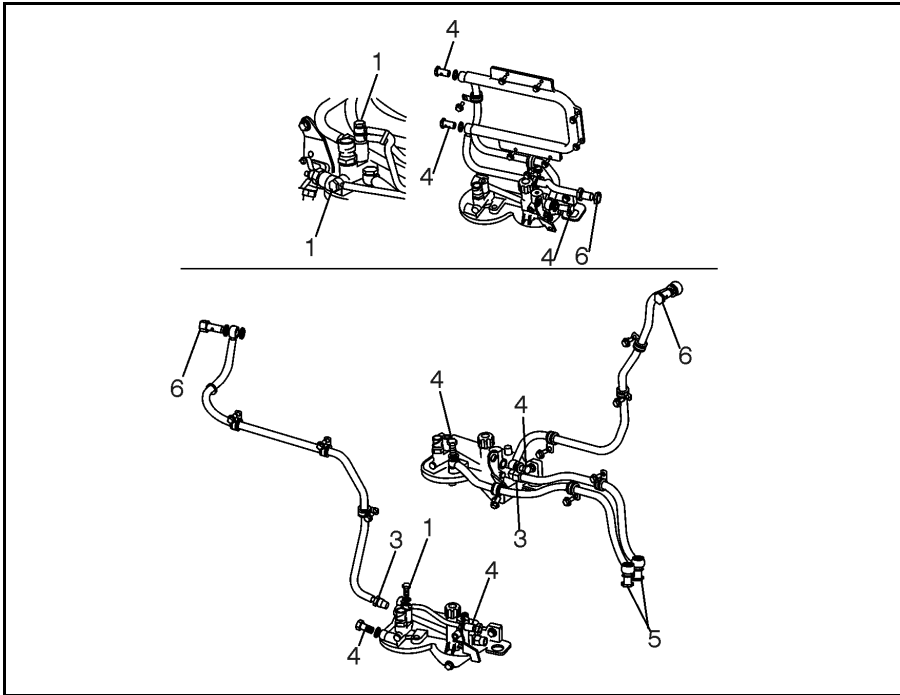

Fuel line fittings: Filter Housing

Attaching Screws, M8 x 1.25 24 ± 4 N.m (18 ± 3 lb-ft)

1	18 ± 3 Nm (13 ± 2 ft-lb)
2	28 ± 4 Nm (20.5 ± 3 ft-lb)
3	30 ± 4 Nm (22 ± 3 ft-lb)
4	35 ± 5 Nm (26 ± 4 ft-lb)
5	40 ± 5 Nm (29.5 ± 4 ft-lb)
6	48 ± 5 Nm (35 ± 4 ft-lb)

Additional Left-Side Engine Components

Alternator	
Mounting Bracket Attaching Screws, M10	48 ± 8 Nm (35 ± 6 lb-ft)
Pad Mount Attaching Screws, M12	85 ± 15 Nm (63 ± 11 lb-ft)
Attaching Screws, Tension Idler Roller	48 ± 8 Nm (35 ± 6 lb-ft)
Pulley Nuts	101 ± 6.5 Nm (75 ± 5 lb-ft)
Inlet Manifold	Torque
Plug, Inlet Manifold	20 ± 3 Nm (15 ± 2 lb-ft)
Air Compressor, Brake System	
Gear Attaching Nut	200 + 50/0 Nm (147+ 37/- 0 lb-ft)
Compressor Attaching Nuts	85 ± 15 Nm (63 ± 11 lb-ft)
Grease Connector	25 ± 4 Nm (18 ± 3 lb-ft)
Attaching Studs	25 ± 4 Nm (18 ± 3 lb-ft)
Fuel Pump	
Attaching Screws (to Power Steering Pumps)	8 +2/-0 Nm (6 + 1/-0 lb-ft)
Banjo Bolts	40 ± 5 Nm (30 ± 4 lb-ft)
Power Steering Pump	
Gear Attaching Nuts	100 ± 10 Nm (74 ± 7 lb-ft)
Attaching Screws	24 ± 4 Nm (18 ± 3 lb-ft)
Refrigerant Compressor, Air Conditioning	
M8 Attaching Screws	24 ± 4 Nm (18 ± 3 lb-ft)

42 SPECIFICATIONS

Aftertreatment Fuel Supply Line

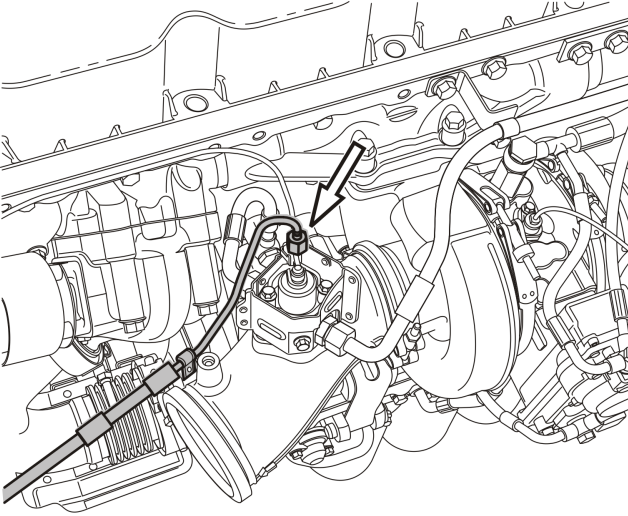

W2005926

1. Aftertreatment Fuel Injector, fuel supply line	15 ± 0.5 Nm (135 \pm 5 in-lb)
2. Mounting Bolts	14 Nm (125 in-lb)
3. Two-Way Check Valve	15 Nm (135 in-lb)
4. Air Line	27 Nm (235 in-lb)

Intake manifold

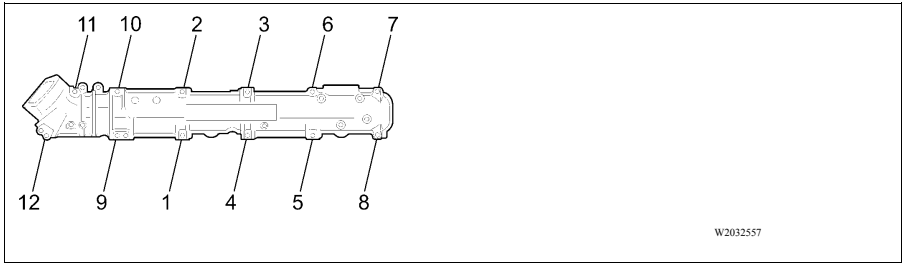

W2052557

Tighten the bolts diagonally from the center outward.

24 ± 4 Nm (18 ± 3 ft-lb)

44 SPECIFICATIONS

Exhaust Manifold

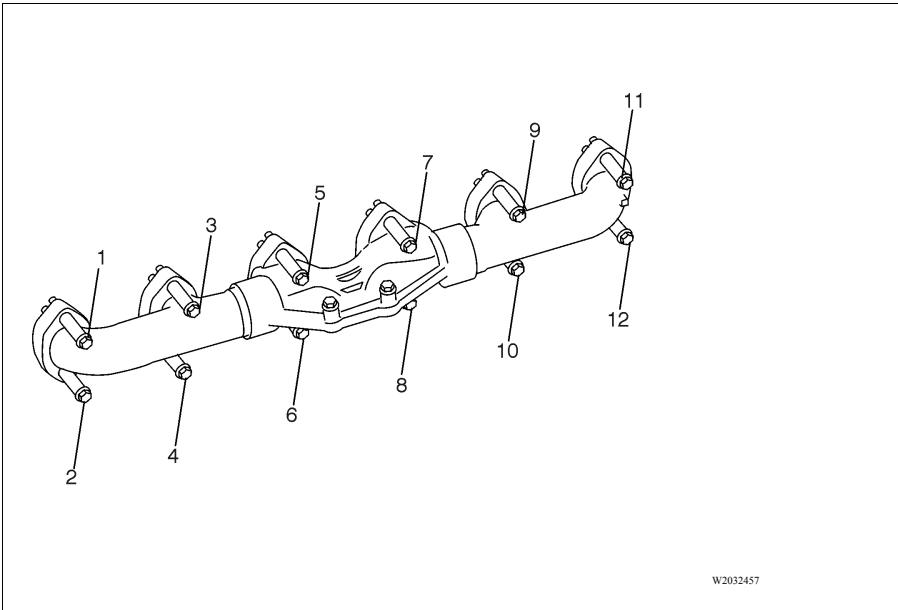

Use anti-seize compound on contact surface of nuts, bolts and screws when reassembled exhaust system components

Step 1. All screws	$5 \pm 1.5 \text{ Nm}$ ($3.5 \pm 1 \text{ lb-ft}$)
Step 2. Tighten bolts 1, 4, 5, 8, 9, 12 in order	$5 \pm 1.5 \text{ Nm}$ ($7.5 \pm 1 \text{ ft-lb}$)
Step 3. Tighten bolts 3, 2, 7, 6, 11, 10, 1, 4, 5, 8, 9, 12 in order	$48 \pm 8 \text{ Nm}$ ($35 \pm 6 \text{ ft-lb}$)

Cooling Duct Cover

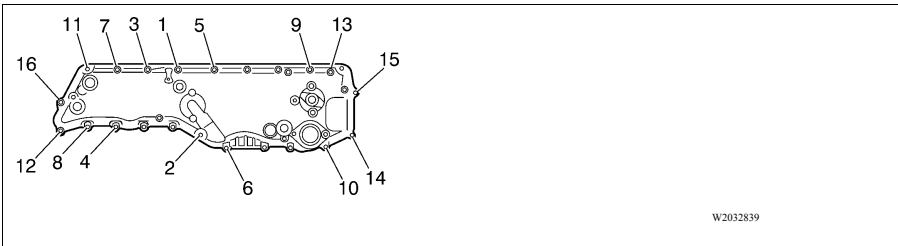

Tighten screws in the order indicated to	$24 \pm 4 \text{ Nm}$ ($18 \pm 3 \text{ lb-ft}$)
--	--

Coolant Pump

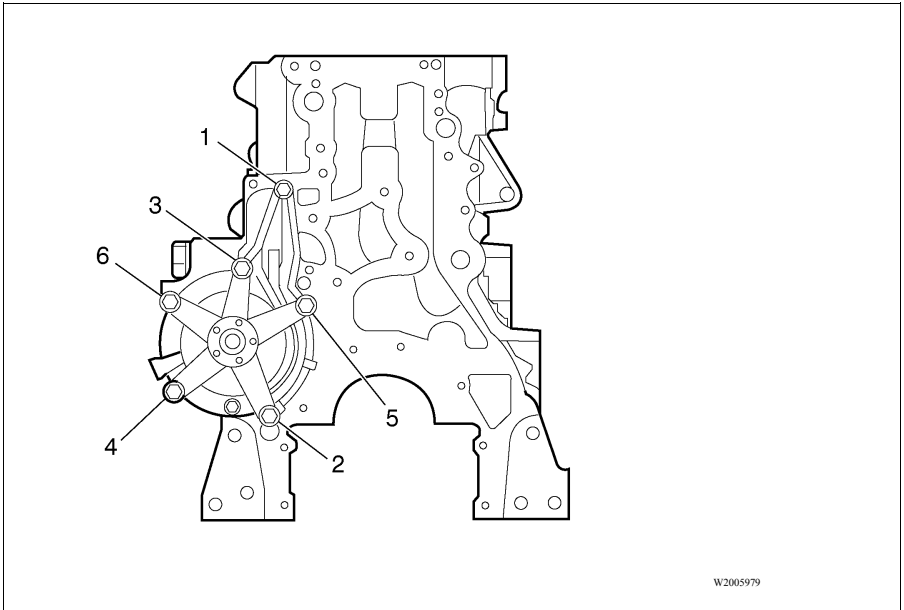

W2005979

Coolant pump (Note: Tighten in sequence twice)	$24 \pm 4 \text{ Nm}$ ($18 \pm 3 \text{ ft-lb}$)
Coolant pump pulley	$24 \pm 4 \text{ Nm}$ ($18 \pm 3 \text{ ft-lb}$)
Coolant pump housing	$48 \pm 8 \text{ Nm}$ ($35 \pm 6 \text{ ft-lb}$)
Front and side cover, thermostat housing	$24 \pm 4 \text{ Nm}$ ($18 \pm 3 \text{ ft-lb}$)
Tensioner	$48 \pm 8 \text{ Nm}$ ($35 \pm 6 \text{ ft-lb}$)
Drive belt idler	$24 \pm 4 \text{ Nm}$ ($18 \pm 3 \text{ ft-lb}$)
Fan hub 15mm hex (wrench size) nut	$48 \pm 8 \text{ Nm}$ ($35 \pm 6 \text{ ft-lb}$)
Viscous fan drive Drive-to-hub	$24 \pm 4 \text{ Nm}$ ($18 \pm 3 \text{ ft-lb}$)

46 SPECIFICATIONS

Tighten Torques front of Engine

Starter motor mounting nuts	
Delco	85 ± 15 Nm (63 ± 11 ft-lb)
Melco	60 ± 6 Nm (44 ± 5 ft-lb)
Starter cables (Bat+, E-)	
Delco	26 ± 1.5 Nm (19 ± 1 ft-lb)
Melco	25 ± 5 Nm (18.5 ± 3.5 ft-lb)
Starter control wire:	
Delco	2.2 ± 0.2 Nm (19.5 ± 2 in-lb)
Melco	4 ± 1 Nm (35 ± 9 in-lb)
Alternator:	
Mounting bracket	48 ± 8 Nm (35 ± 6 ft-lb)
Pad mounts	65.5 ± 7.5 Nm (48 ± 5.5 ft-lb)
Pulley nut	101.5 ± 6.5 Nm (75 ± 5 ft-lb)
Battery terminal	6.5 ± 0.25 Nm (57.5 ± 2.5 in-lb)
Ground terminal	6.2 ± 0.5 Nm (55 ± 5 in-lb)
I, R terminals	2.3 ± 0.5 Nm (20 ± 5 in-lb)
AC refrigerant compressor mounting bolts	24 ± 4 Nm (18 ± 3 ft-lb)
Wiring harness conduit to block	24 ± 3 Nm (18 ± 2 ft-lb)
Wiring harness conduit cover	3.5 ± 0.5 Nm (31 ± 4.4 in-lb)
Cable channel cover	3.5 ± 0.5 Nm (31 ± 4.4 in-lb)

Air Compressor

Air compressor mounting bolts	85 ± 15 Nm (63 ± 11 ft-lb)
Air compressor out connection	130 ± 20 Nm (96 ± 15 ft-lb)
Air compressor gear	270 ± 20 Nm (200 ± 15 ft-lb)

Engine Component Torque Specifications (Critical Fasteners)

Note: All components are to be clean and free from foreign material or corrosion. Assemblies are to be made using suitable tools and procedures so that no permanent damage will occur as a result of the assembly.

Threads, washers, under head of screws and washer face of nuts should be lubricated with clean engine oil unless otherwise specified.

The following listed fasteners require the use of a calibrated manual torque wrench. If an adapter is required in combination with a torque wrench, a correction factor must be applied to the torque wrench reading in order to obtain accurate fastener torque values. Fasteners noted by an asterisk (*) require retorquing after engine run-in.

Fastener Reuse

	CAUTION
Repeated tightening of fasteners and threaded components reduces their capacity to function adequately. The following table describes the various items and the limits of their reusability. Failure to conform to these limits may result in severe component damage.	

Fastener Reuse

Fstteners	Example	Reusable Limit	Reusable Recommendation
Highly loaded screws (Phosphating plus oil)	Cylinder Head Injector yoke Camshaft Bearing Housing Transmission Flywheel	5 times	Apply engine oil on threads and under screw heads. Mark bolt head with an indentation. Dry mounting for new screws (delivered with oil pre-applied and anti-rust treatment for spare parts). If a part is replaced, e.g., cylinder head, also replace the screws.
Highly loaded screws (Phosphating plus oil)	Connect- ing rods for D13F engines	5 times	Apply Molykote grease “G-Rapid+MoS2” (spray).
Special screws (specific shape)	Oil pan and valve cover	No limit	No limit if no cracks, corrosion or damage to the flat surface.

48 SPECIFICATIONS

Fastener Reuse (cont'd.)

Fssteners	Example	Reusable Limit	Reusable Recommendation
Stainless steel studs and flange locknuts (Spiralock)	Turbocharger	5 times	If turbocharger or the exhaust manifold is replaced, also replace the studs and nuts.
Prevailing torque feature screws (Dri-Loc Plastic or Tuflock)	Piston cooling jets, transmission plate	5 times	
Standard screws (ZIB)	Property class 8.8	No limit	No limit if no cracks, corrosion or damage to the flat surface.

Fastener Reuse

Fssteners	Example	Reusable Limit	Reusable Recommendation
V-nipple with taper threads	With locking fluid pre-applied	Do not reuse	Before fitting the new nipple, clean the hole with a nipple tap and apply Loctite® 270 on the nipple thread, or use a new coated nipple.
Taper plus or nipples	With sealer fluid pre-applied	Do not reuse	Before fitting the new nipple, clean the hole with a nipple tap and apply Loctite® 542 on the nipple thread, or use a new coated nipple.

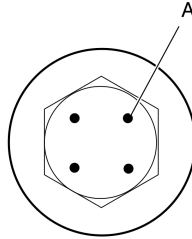

W2005481

Bolt Head Punch Marks



CAUTION

Bolts for the following components may be reused four times only. The heads of these bolts must be marked with a punch (A) after each use. When re-using bolts, the bolt head and threads must be lubricated with clean engine oil. Do not lubricate new bolts as they are already lubricated.

- CYLINDER HEAD BOLTS
- CAMSHAFT and ROCKER SHAFT BOLTS
- FLYWHEEL BOLTS
- MAIN BEARING BOLTS
- CONNECTING ROD BOLTS



CAUTION

Do not re-use timing gear mounting plate bolts. Do not re-use timing gear mounting bolts. Do not re-use piston spray nozzle bolts

50 SPECIFICATIONS

Gasket and Seal Reuse

Gasket and Seal Reuse

Components	Example	Reusable Limit	Reuse Recommendations
Gaskets (steel)	Cylinder head	Do not reuse	Discard the old gasket and substitute new if the head is removed.
Gaskets (hot)	Exhaust manifold, turbocharger, EGR system	Do not reuse	Discard the old gasket and substitute new if associated components are removed.
Rubber Gaskets (special)	Sealing strips (coolant duct cover, valve cover and oil pan, timing gear cover)	No limit if no damage and no leaks	Remove old silicone from the T joints. Clean the surface. Apply fresh silicone.
Rubber Gaskets (standard)	O-rings and sealing rings	No limit if no damage and no leaks	
Bonded seals, steel/rubber gasket	Nipples, hollow screws and oil filter housing	No limit if no damage and no leaks	
Valve seals	Valve stems	No limit if no damage and no leaks	Discard old seals and substitute new if the gasket is removed.
Crankshaft seals		Do not reuse	Discard old seals and substitute new if removed. Do not apply oil on the inside or outside diameters of the seal during assembly. SEALS MUST BE DRY MOUNTED.

Gasket and Seal Reuse

Components	Example	Reusable Limit	Reuse Recommendations
Sealant agent (One component RTV1)	Sealing between: Timing Gear Plate and Cylinder Block Flywheel Housing and Timing Gear Plate Front Cover and Cylinder Block Timing Gear Cover and Gear Plate (Dow Corning® LDC 7091 Silicone - can substitute Dow Corning®832)	Do not reuse	Remove the old RTV1 sealant. Clean the Surface. Apply fresh RTV1 sealant. IMPORTANT: Remove the old silicone from the T joints and apply fresh.

52 SPECIFICATIONS

Engine Lubricants and Sealants

Use only the following recommended sealing compounds and lubricants.

Note: All genuine cylinder head gaskets are pre-coated and do not require any type of sealing compound. When installing new gaskets, clean and degrease gasket sealing surfaces to avoid leaks.

Location	Sealant or Lubricant
Cup plugs/threaded plugs	Loctite® 277 or equivalent / Teflon® thread sealer
Cylinder liner seat	1161231 sealant
Oil filter seal	Clean engine oil
Holding metal parts in place	Petroleum jelly
Valve stems and guides	Clean engine oil
Engine front cover/flywheel housing/timing gear cover	3092340 sealant
Engine parts, fasteners and washers	Clean engine oil
Exhaust manifold studs	High temperature 1161929 anti-seize
Oil cooler assembly O-ring	Clean engine oil
O-rings, coolant, EPDM	Clean coolant, or Dow Corning® 55
O-rings (except as noted)	Dow Corning® 55 O-ring lubricant
Threaded sensors	Sealing compound on threads
Turbocharger mounting nuts	1161929 anti-seize

Note: All part numbers are for reference only, you should always refer to truck BOM's before ordering parts.

Engine Fault Codes

Description	Fault Code
PID	
Fan speed	PID26
Preheat Relay	PID45
Particulate Trap Differential Pressure	PID81
Vehicle Speed	PID84
Cruise control status	PID85
Pedal message	PID91
Fuel pressure	PID94
Water in fuel sensor	PID97
Oil Level	PID98
Oil Pressure	PID100
Boost Pressure	PID102
Turbo speed	PID103
Boost Temperature	PID105
Ambient Pressure	PID108
Coolant Temperature	PID110
Coolant Level	PID111
Crankcase Pressure /(Crankhouse Pressure)	PID153
ECU battery potential	PID158
Ambient Air Temperature	PID171
Exhaust Gas Temperature	PID173
Oil Temperature	PID175
Transmission Oil Temperature	PID177
Immobilizer	PID224
Calibration Factor (K)	PID228

54 SPECIFICATIONS

Engine Fault Codes

Description	Fault Code
Total Vehicle Distance	PID245
Time data failure	PID251
Date data failure	PID252
Relative Air Humidity	PID354
Compressor Discharge Temperature	PID404
EGR Diff Pressure	PID411
EGR Temperature After Cooler	PID412

Engine Fault Codes

Description	Fault Code
SID	
Injector 1	SID1
Injector 2	SID2
Injector 3	SID3
Injector 4	SID4
Injector 5	SID5
Injector 6	SID6
Water-in-fuel Valve	SID18
CAM Speed sensor	SID21
Crank Speed sensor	SID22
Variable Geometry Turbocharger Actuator #1	SID27
Cooling Fan control	SID33
Starter Output	SID39
Preheat sense 1	SID70
Preheat sense 2	SID71
EGR Valve 1 (LISK)	SID146
Buffered IVS	SID230
CAN1 J1939 communication link	SID231
5 V supply	SID232
Programme memory	SID240
Calibration memory EEPROM	SID253
Controller 1	SID254

56 SPECIFICATIONS

Engine Fault Codes

PPID	
EGR Mass Flow	PPID35
ECU Temperature	PPID55
VGT SRA Temperature	PPID89
VCB	PPID122
NOx sensor gas outlet	PPID270
Air temperature for humidity compensation	PPID272
Soot level	PPID326
After treatment injection shut-off valve	PPID328
After treatment fuel injector	PPID329
Discharge Recirculator Valve Solenoid	PPID330
Engine fan thermal switch	PPID333
Ash Level in the Diesel Particle filter	PPID337
Exhaust gas temperature sensor #2	PPID387
Exhaust gas temperature sensor #3	PPID436
After treatment injector fuel pressure	PPID437

Engine Fault Codes

Description	Fault Code
PSID	
Aftertreatment System Conditioning	PSID25
Insufficient reagent quality	PSID40
Too low reagent consumption	PSID41
Interruption of dosing activity	PSID42
Incorrect EGR flow	PSID43
Deactivation of EGR	PSID44
High NOx - Root cause unknown	PSID45
NOx monitoring failure	PSID46
Particulate trap regeneration	PSID47
Boost Air system	PSID98
ATI system	PSID108
VIN check 1	PSID161
VIN check 2	PSID162
CAN1 J1939 communication, time-out	PSID201
CAN1 J1939 communication, time-out	PDIS202
CAN2 J1939 communication link	PSID232

58 SPECIFICATIONS

FMI Table

Failure Mode Indicator	Description
0	DATA VALID BUT ABOVE NORMAL OPERATING RANGE – MOST SEVERE LEVEL
1	DATA VALID BUT BELOW NORMAL OPERATING RANGE – MOST SEVERE LEVEL
2	DATA ERRATIC, INTERMITTENT OR INCORRECT
3	VOLTAGE ABOVE NORMAL, OR SHORTED TO HIGH SOURCE
4	VOLTAGE BELOW NORMAL, OR SHORTED TO LOW SOURCE
5	CURRENT BELOW NORMAL, OR OPEN CIRCUIT
6	CURRENT ABOVE NORMAL, OR GROUNDED CIRCUIT
7	MECHANICAL SYSTEM NOT RESPONDING OR OUT OF ADJUSTMENT
8	ABNORMAL FREQUENCY OR PULSE WIDTH OR PERIOD
9	ABNORMAL UPDATE RATE
10	ABNORMAL RATE OF CHANGE
11	ROOT CAUSE NOT KNOWN
12	BAD INTELLIGENT DEVICE OR COMPONENT
13	OUT OF CALIBRATION
14	SPECIAL INSTRUCTION
15	DATA VALID BUT ABOVE NORMAL OPERATING RANGE – LEAST SEVERE LEVEL

Conversion Chart

Conversion Units			Multiply By:
Length Calculations			
Inches (in)	to	Millimeters (mm)	25.40
Inches (in)	to	Centimeters (cm)	2.540
Feet (ft)	to	Centimeters (cm)	30.48
Feet (ft)	to	Meters (m)	0.3048
Yards (yd)	to	Centimeters (cm)	91.44
Yards (yd)	to	Meters (m)	0.9144
Miles	to	Kilometers (km)	1.609
Millimeters (mm)	to	Inches (in)	0.03937
Centimeters (cm)	to	Inches (in)	0.3937
Centimeters (cm)	to	Feet (ft)	0.0328
Centimeters (cm)	to	Yards (yd)	0.0109
Meters (m)	to	Feet (ft)	3.281
Meters (m)	to	Yards (yd)	1.094
Kilometers (km)	to	Miles	0.6214

60 SPECIFICATIONS

Conversion Chart

Conversion Units			Multiply By:
Volume Calculations			
Cubic Inches (cu-in)	to	Cubic Centimeters (cu-cm)	16.387
Cubic Inches (cu-in)	to	Liters (L)	0.01639
Quarts (qt)	to	Liters (L)	0.9464
Gallons (gal)	to	Liters (L)	3.7854
Cubic Yards (cu-yd)	to	Cubic Meters (cu-m)	0.7646
Cubic Centimeters (cu-cm)	to	Cubic Inches (cu-in)	0.06102
Liters (L)	to	Cubic Inches (cu-in)	61.024
Liters (L)	to	Quarts (qt)	1.0567
Liters (L)	to	Gallons (gal)	0.2642
Cubic Meters (cu-m)	to	Cubic Yards (cu-yd)	1.308

Conversion Chart

Conversion Units			Multiply By:
Area Calculations			
Square Inches (sq-in)	to	Square Millimeters (sq-mm)	645.2
Square Inches (sq-in)	to	Square Centimeters (sq-cm)	6.452
Square Feet (sq-ft)	to	Square Centimeters (sq-cm)	929.0
Square Feet (sq-ft)	to	Square Meters (sq-m)	0.0929
Square Yards (sq-yd)	to	Square Meters (sq-m)	0.8361
Square Miles (sq-miles)	to	Square Kilometers (sq-km)	2.590
Square Millimeters (sq-mm)	to	Square Inches (sq-in)	0.00155
Square Centimeters (sq-cm)	to	Square Inches (sq-in)	0.155
Square Centimeters (sq-cm)	to	Square Feet (sq-ft)	0.001076
Square Meters (sq-m)	to	Square Feet (sq-ft)	10.76
Square Meters (sq-m)	to	Square Yards (sq-yd)	1.196
Square Kilometers (sq-km)	to	Square Miles (sq-miles)	0.3861

62 SPECIFICATIONS

CONVERSION CHART

Conversion Units			Multiply By:
Weight Calculations			
Ounces (oz)	to	Grams (g)	28.5714
Pounds (lb)	to	Kilograms (kg)	0.4536
Pounds (lb)	to	Short Tons (US tons)	0.0005
Pounds (lb)	to	Metric Tons (t)	0.00045
Short Tons (US tons)	to	Pounds (lb)	2000
Short Tons (US tons)	to	Kilograms (kg)	907.18486
Short Tons (US tons)	to	Metric Tons (t)	0.90718
Grams (g)	to	Ounces (oz)	0.035
Kilograms (kg)	to	Pounds (lb)	2.205
Kilograms (kg)	to	Short Tons (US tons)	0.001102
Kilograms (kg)	to	Metric Tons (t)	0.001
Metric Tons (t)	to	Pounds (lb)	2205
Metric Tons (t)	to	Short Tons (US tons)	1.1023
Metric Tons (t)	to	Kilograms (kg)	1000
Force Calculation			
Ounces Force (ozf)	to	Newtons (N)	0.2780
Pounds Force (lbf)	to	Newtons (N)	4.448
Pounds Force (lbf)	to	Kilograms Force (kgf)	0.456
Kilograms Force (kgf)	to	Pounds Force (lbf)	2.2046
Kilograms Force (kgf)	to	Newtons (N)	9.807
Newtons (N)	to	Kilograms Force (kgf)	0.10196
Newtons (N)	to	Ounces Force (ozf)	3.597
Newtons (N)	to	Pounds Force (lbf)	0.2248

CONVERSION CHART

Conversion Units			Multiply By:
Torque Calculation			
Pound Inches (lb-in)	to	Newton Meters (N·m)	0.11298
Pound Feet (lb-ft)	to	Pound Feet (lb-ft)	1.3558
Pound Feet (lb-ft)	to	Kilograms Force per Meter (kgfm)	0.13825
Newton Meters (N.m)	to	Pound Inches (lb-in)	8.851
Newton Meters (N.m)	to	Pound Feet (lb-ft)	0.7376
Newton Meters (N.m)	to	Kilograms Force per Meter (kgfm)	0.10197
Kilograms Force per Meter (kgfm)	to	Pound Feet (lb-ft)	7.223
Kilograms Force per Meter (kgfm)	to	Newton Meters (N.m)	9.807
Radiator Specific Heat Dissipation Calculations to			
British Thermal Unit per Hour (BTU/hr)	to	Kilowatt per Degree Celsius (kW/°C)	0.000293
Kilowatt per Degree Celsius (kW/°C)	to	British Thermal Unit per Hour (BTU/hr)	3414.43
Temperature Calculations			
Degrees Fahrenheit (°F)	to	Degrees Celsius (°C)	(°F - 32) x 0.556
Degrees Celsius (°C)	to	Degrees Fahrenheit (°F)	(1.8 x °C) + 32
Power Calculations			
Horsepower (hp)	to	Kilowatts (kW)	0.74627
Kilowatts (kW)	to	Horsepower (hp)	1.34

64 SPECIFICATIONS

CONVERSION CHART

Conversion Units			Multiply By:
Pressure Calculations			
Atmospheres (atm)	to	Bars (bar)	1.01325
Atmospheres (atm)	to	Kilopascals (kPa)	101.325
Bars (bar)	to	Atmospheres (atm)	0.98692
Bars (bar)	to	Kilopascals (kPa)	100
Bars (bar)	to	Pounds per Square Inch (psi)	14.5037
Inches of Mercury (in Hg)	to	Kilopascals (kPa)	3.377
Inches of Water (in H ₂ O)	to	Kilopascals (kPa)	0.2491
Pounds per Square Inch (psi)	to	Kilopascals (kPa)	6.895
Pounds per Square Inch (psi)	to	Bar (bar)	0.06895
Kilopascals (kPa)	to	Atmospheres (atm)	0.00987
Kilopascals (kPa)	to	Inches of Mercury (in Hg)	0.29612
Kilopascals (kPa)	to	Inches of Water (in H ₂ O)	4.01445
Kilopascals (kPa)	to	Pounds per Square Inch (psi)	0.145
Fuel Performance Calculations			
Miles per Gallon (mile/gal)	to	Kilometers per Liter (km/L)	0.4251
Kilometers per Liter (km/L)	to	Miles per Gallon (mile/gal)	2.352
Velocity Calculations			
Miles per Hour (mile/hr)	to	Kilometers per Hour (km/hr)	1.609
Kilometers per Hour (km/hr)	to	Miles per Hour (mile/hr)	0.6214
Volume Flow Calculations			
Cubic Feet per Minute (cu-ft/min)	to	Liters per Minute (L/min)	28.32
Liters per Minute (L/min)	to	Cubic Feet per Minute (cu-ft/min)	0.03531

Engine Dimensions

Cylinder Head

Maximum unevenness (bottom face)	0.1 mm (0.004 inch)
----------------------------------	---------------------

Cylinder Head Bolts

Quantity	38
Thread size	M16
Length	200 mm (7.87 inches)

Cylinder Block

Length	1052 mm (41.42 inches)
Height, upper block face — crankshaft center	422 mm (16.61 inches)
Height, lower block face — crankshaft center	120 mm (4.72 inches)

Cylinder Liner

Type	Wet, replaceable
Height of sealing surface above block face	0.15–0.21 mm (0.006–0.008 inch)
Number of sealing rings per cylinder liner	1 + 3

Piston

Number of ring grooves	3
Front marking	Arrow pointing forwards

66 SPECIFICATIONS

Piston Rings

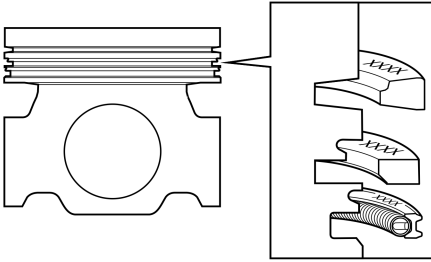

T2022726

Quantity	2
Labelling	Up (color marking to left of gap)
Piston ring clearance in groove	
Upper compression ring	Trapezium profile
Lower compression ring	0.09–0.14 mm (0.0035–0.0055 inch)
Oil Scraper Ring	
Quantity	1
Labelling	Up (color marking to left of gap)
Piston ring clearance in groove	0.05–0.10 mm (0.0019–0.0039 inch)

Valve Mechanism

Note: When replacing valve seats, also replace the valves.

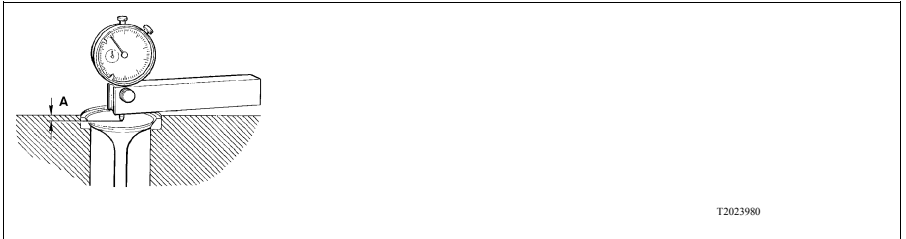

T2023980

Measurement (A) between valve head and cylinder head face

Inlet	1.0 mm (0.039 inch) minimum
Exhaust	1.35 mm (0.053 inch) minimum
Maximum wear value	
Inlet	1.7 mm (0.067 inch)
Exhaust	1.5 mm (0.059 inch)
Valve lash (clearance) cold engine, adjustment value	
Inlet	0.2 mm (0.008 inch)
Exhaust	0.8 mm (0.031 inch)
Exhaust, Volvo Engine Brake	1.0 mm (0.394 inch)
Valve lash (clearance) cold engine, check value	
Inlet	0.15–0.25 mm (0.006–0.009 inch)
Exhaust	0.75–0.85 mm (0.029–0.033 inch)
Exhaust, Volvo Engine Brake	0.95–1.05 mm (0.037–0.041 inch)

Rocker Arms

Rocker arm bearing clearance	0.08 mm (0.003 inch) maximum
Rocker arm roller clearance	0.1 mm (0.004 inch) maximum

68 SPECIFICATIONS

Valve Guides

Length Inlet/Exhaust	83.5 mm (3.287 inches)
Inner diameter Inlet/Exhaust	8 mm (0.315 inch)
Height above cylinder head spring surface Inlet/Exhaust	24.5 ± 0.2 mm (0.965 ± 0.008 inch)

Valve Springs

Inlet valve spring Length unloaded	73.8 mm (2.91 inches)
Exhaust outer valve spring Length unloaded	73.8 mm (2.91 inches)
Exhaust inner valve spring Length unloaded	70.5 mm (2.78 inches)

Engine Timing Gear

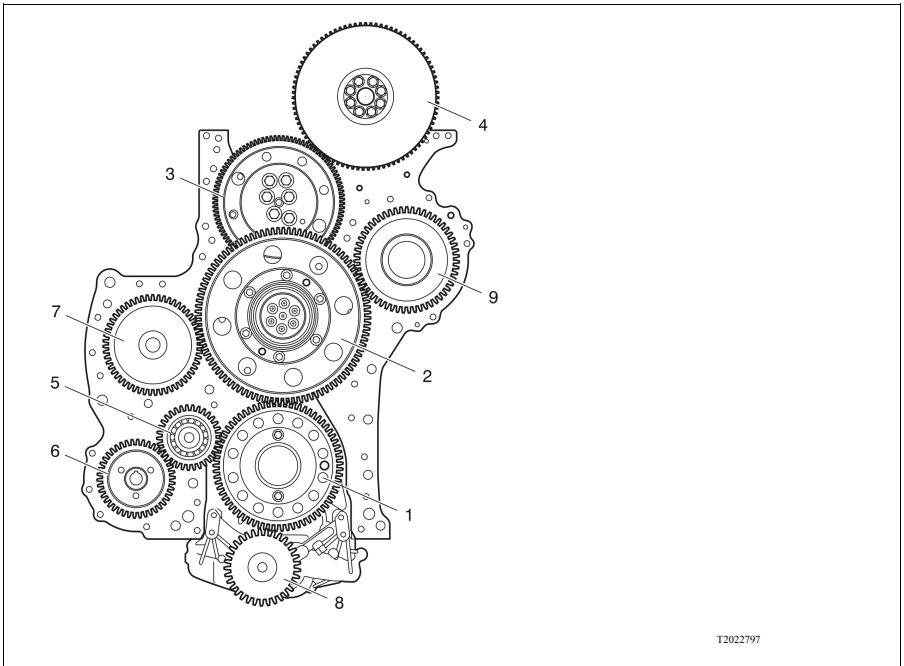

T2022797

1. Drive gear, crankshaft	63
2. Idler gear, outer and inner drive	Outer: 84, Inner: 56
3. Idler gear, adjustable	73
4. Drive gear, camshaft	84
5. Idler gear, power steering pump	29
6. Drive gear, power steering pump	36
7. Drive gear, air compressor	48
8. Drive gear, lubricating oil pump	31
9. Engine power take-off (optional)	50
Idler gear to camshaft gear backlash (adjustable)	0.05–0.15 mm (0.002–0.006 inch)
Oil pump backlash	0.05–0.40 mm (0.002–0.016 inch)
Idler gear axle-to-bushing clearance	0.05 mm (0.002 inch) maximum
All other drive and idler gear, backlash	0.05–0.17 mm (0.002–0.007 inch)

70 SPECIFICATIONS

Camshaft

Control of camshaft settings, cold engine and valve clearance for cylinder 1 inlet valve equals zero.

Inlet valve for cylinder 1 should be open 1.6 ± 0.3 mm (0.063 ± 0.012 inch) at a flywheel position of 6 degrees after TDC.

When checking, the timing gears must be rotated in the correct direction (counterclockwise) in order to take up all gear tooth clearance.

Axle arrangements	Gear
Number of bearings	7
Standard bearing journal diameter	69.97–70.00 mm (2.754–2.760 inch)
Undersize bearing journal diameters	
0.25 mm (0.010 inch)	69.72–69.78 mm (2.746–2.747 inches)
0.50 mm (0.020 inch)	69.47–69.53 mm (2.735–2.737 inches)
0.75 mm (0.030 inch)	69.22–69.28 mm (2.725–2.728 inches)

Valve lift at zero play Inlet Exhaust Volvo Engine Brake™	13.1 mm (0.520 inch) 12.5 mm (0.490 inch)
Permitted wear, entire camshaft profile	0.1 mm (0.0039 inch) maximum
Unit injector, stroke	18 mm (0.710 inch)

Wear value	
Max end float	0.24 mm (0.0094 inch)
Bearing, permitted diametrical wear	0.1 mm (0.0039 inch) maximum

Camshaft Bearings

Camshaft bearing thickness, standard	1.92 mm (0.075 inch)
Oversize	
0.25 mm (0.010 inch)	2.04 mm (0.080 inch)
0.50 mm (0.020 inch)	2.17 mm (0.085 inch)
0.75 mm (0.030 inch)	2.29 mm (0.090 inch)

Crank Mechanism Main Bearing Journals

Standard diameter (Ø)	108.0 mm (4.25 inches)
Undersize diameter	
0.25 mm (0.010 inch)	107.75 mm (4.2421 inches)
0.50 mm (0.020 inch)	107.50 mm (4.2323 inches)
0.75 mm (0.030 inch)	107.25 mm (4.2224 inches)
1.00 mm (0.040 inch)	107.00 mm (4.2126 inches)
1.25 mm (0.050 inch)	106.75 mm (4.2027 inches)
Surface finish, main bearing journal	Ra 0.25
Surface finish, radius	Ra 0.4
Width, axial bearing pin (A), standard	47.0 mm (1.850 inches)
Oversize	
0.2 mm (0.008 inch), axial bearing 0.1 mm (0.004 inch)	47.2 mm (1.858 inches)
0.4 mm (0.016 inch), axial bearing 0.2 mm (0.008 inch)	47.4 mm (1.866 inches)
0.6 mm (0.241 inch), axial bearing 0.3 mm (0.012 inch)	47.6 mm (1.874 inches)
Recess radius (R)	4.0 mm (0.157 inch)

72 SPECIFICATIONS

Thrust Washers (Axial Bearing)

Standard width (B)	3.18 mm (0.125 inch)
Oversize	
0.1 mm (0.004 inch)	3.28 mm (0.129 inch)
0.2 mm (0.008 inch)	3.38 mm (0.133 inch)
0.3 mm (0.012 inch)	3.48 mm (0.137 inch)
0.4 mm (0.016 inch)	3.58 mm (0.141 inch)

Main Bearings

Standard thickness (D)	2.48 mm (0.098 inch)
Oversize	
0.25 mm (0.010 inch)	2.61 mm (0.103 inch)
0.50 mm (0.020 inch)	2.74 mm (0.108 inch)
0.75 mm (0.030 inch)	2.86 mm (0.112 inch)
1.00 mm (0.040 inch)	2.98 mm (0.117 inch)
1.25 mm (0.050 inch)	3.11 mm (0.122 inch)
Main bearing maximum permitted diametrical wear value	0.05–0.12 mm (0.002–0.005 inch)

Connecting Rod Journals

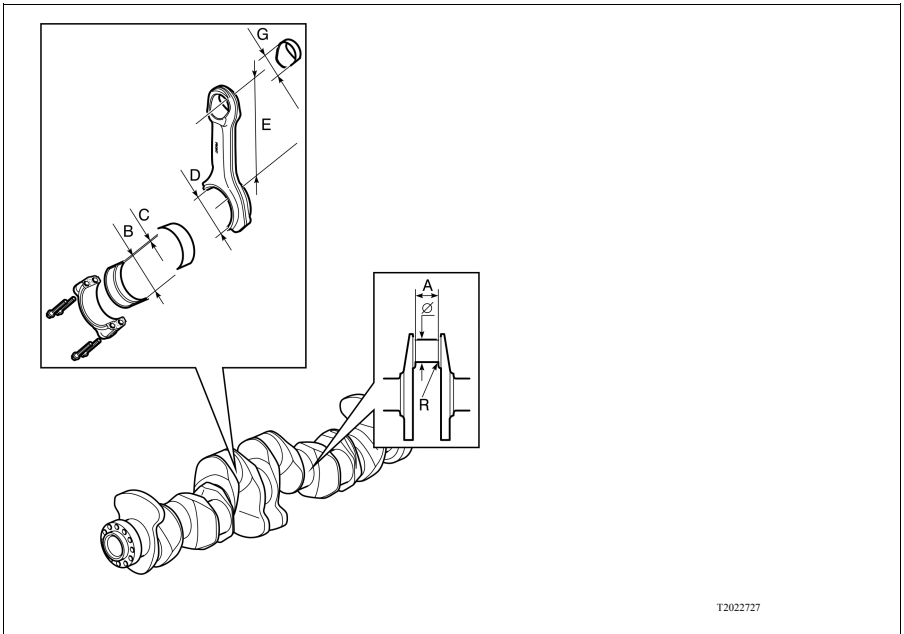

T2022727

Diameter (Ø)	99.0 mm (3.898 inches)
Undersize	
0.25 mm (0.010 inch)	98.75 mm (3.888 inches)
0.50 mm (0.020 inch)	98.50 mm (3.878 inches)
0.75 mm (0.030 inch)	98.25 mm (3.868 inches)
1.00 mm (0.040 inch)	98.00 mm (3.858 inches)
1.25 mm (0.050 inch)	97.75 mm (3.848 inches)
Surface finish, bearing journal	Ra 0.25
Surface finish, radius	Ra 0.4
Width (A)	57.0 mm (2.244 inches)
Recess radius (R)	4.0 mm (0.157 inch)

74 SPECIFICATIONS

Connecting Rod Bearings

Standard thickness (C)	2.39 mm (0.094 inch)
Oversize	
0.25 mm (0.010 inch)	2.14 mm (0.084 inch)
0.50 mm (0.020 inch)	1.89 mm (0.074 inch)
0.75 mm (0.030 inch)	1.64 mm (0.064 inch)
1.00 mm (0.040 inch)	1.39 mm (0.054 inch)
1.25 mm (0.050 inch)	1.14 mm (0.044 inch)

Connecting Rod

Wear Value	
End play, connecting rod at crankshaft journal ¹	0.35 mm (0.0138 inch) maximum
Big-end bearing, diametrical play	0.1 mm (0.004 inch)

¹ The measurements refer to lubricated components.

Marking:

The FRONT marking on the connecting rod faces forward

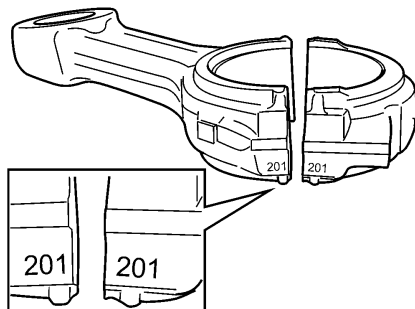

T2019085

The connecting rod and cap are marked as a pair with a three-digit serial number.

Flywheel, Mounted

Axial runout (manual transmission) measurement radius	150 mm (5.91 inches) Less than 0.21 mm (0.008 inch)
---	--

Flywheel Housing, Mounted

Axial runout of contact surface against clutch housing	0.2 mm (0.008 inch) maximum
Radial runout of guide against clutch housing	0.26 mm (0.010 inch) maximum

Crankshaft

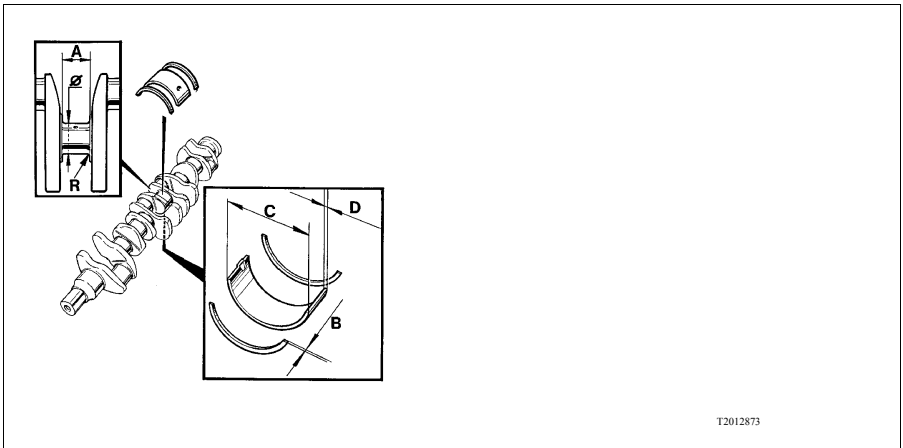

T2012873

Wear value

Crankshaft axial clearance ¹	0.4 mm (0.016 inch) maximum
---	-----------------------------

Machining value

Main bearing and connecting rod bearing journal out-of-round	0.006 mm (0.0002 inch) maximum
Main bearing and connecting rod bearing journal taper	0.02 mm (0.0008 inch) maximum
Runout of middle bearing	0.15 mm (0.006 inch) maximum

¹ The measurements refer to lubricated components.

76 ENGINE COMPONENT AND LOCATION

Cylinder Head

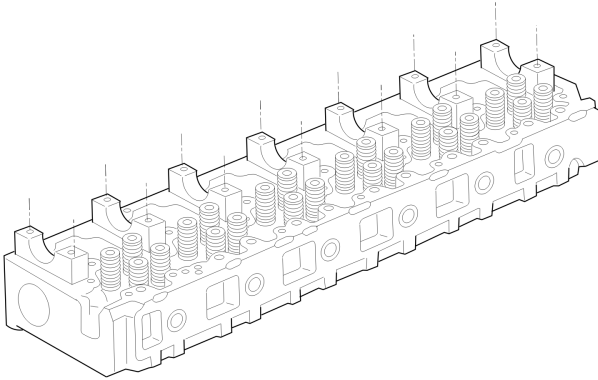

W2033297

Main features of the cylinder head are:

- One-piece cast iron
- Integral thermostat housing

Separate chambers for exhaust and inlet at each cylinder make this a "crossflow" design. The fuel channel, drilled from front to rear, connects with grooves machined around each injector opening. A plug at the rear of the cylinder head seals this channel.

Camshaft and Valve Train

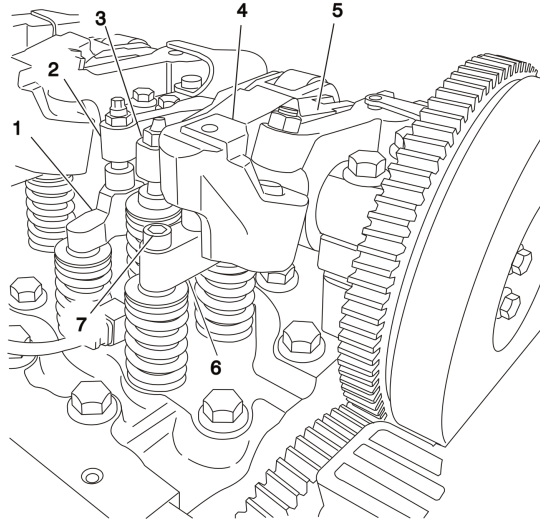

W2033300

- | | |
|------------------------------|----------------------------------|
| 1. Inlet Valve Yoke (Bridge) | 5. Volvo Engine Brake Rocker Arm |
| 2. Inlet Valve Rocker Arm | 6. Exhaust Valve Yoke (Bridge) |
| 3. Injector Rocker Arm | 7. Shim Retaining Screw |
| 4. Exhaust Valve Rocker Arm | |

The engine has an overhead camshaft and rocker arm shaft in support of four valves per cylinder. The camshaft rides on seven journals with a bearing cap and support block (saddle) at each point. The bearing inserts (shells), bearing caps and support blocks are replaceable.

In standard configuration (with VGT exhaust brake only), there are three cams for each cylinder, including inlet, injection and exhaust. There are four cams per cylinder in the optional configuration (VGT exhaust brake plus Volvo Engine Brake) with the addition of a "brake" cam at each cylinder.

The rocker arms are positioned on the shaft (front to back) in the order of inlet, injector, exhaust and brake, if so equipped. Both the inlet and exhaust rocker arms each drive the valve pairs via a pinless yoke (bridge). On engines equipped with Volvo Engine Brake, the "brake" rocker arm works in combination with the exhaust rocker arm to precisely control the opening and closing of the exhaust valves for engine braking.

Exhaust valve yokes include a shim for adjustment. Replaceable valve guides and seats are made of alloyed cast iron and steel respectively. All valve guides have oil seals. Exhaust valves have double valve springs.

78 ENGINE COMPONENT AND LOCATION

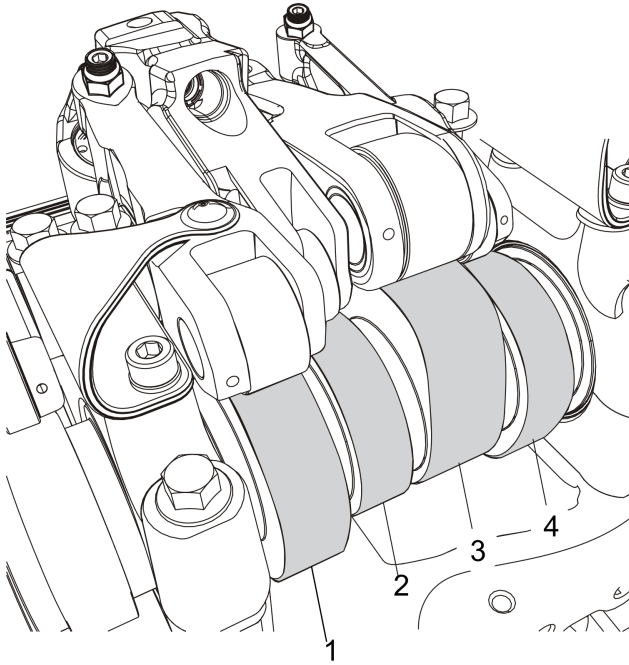

W2033303

- | | |
|----------------------|-----------------|
| 1. Exhaust Brake Cam | 3. Injector Cam |
| 2. Exhaust Cam | 4. Inlet Cam |

Rollers in the ends of the rocker arms contact the cam shaft. The contacts with the yokes have ball sockets for flexibility.

The camshaft is induction-hardened. Timing marks for valve and injector adjustment are located on the flange forward of the No. 1 camshaft journal. These marks are for adjusting valve clearance. They do not apply to camshaft timing.

Camshaft thrust washers are integral on the No. 7 journal bearing. Smooth rotation is ensured by means of a vibration damper on the camshaft gear. Teeth on the damper interact with the camshaft position sensor for input to the EECU.

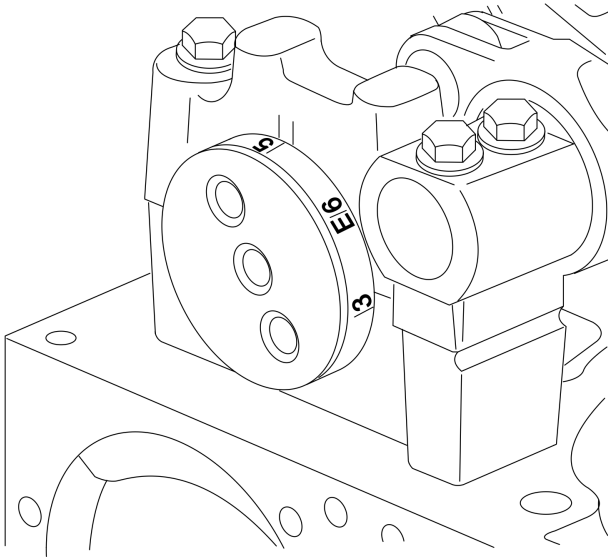

W2033306

Timing marks on the camshaft provide for valve and injector adjustment. Volvo Engine Brake includes its own electronic control governed by driver's choice through a switch near the steering wheel. This control mounts on the cylinder head between the No. 3 and No. 4 cylinder rocker arms. The wiring harness includes additional wire leads for Volvo Engine Brake.

80 ENGINE COMPONENT AND LOCATION

Cylinder Block

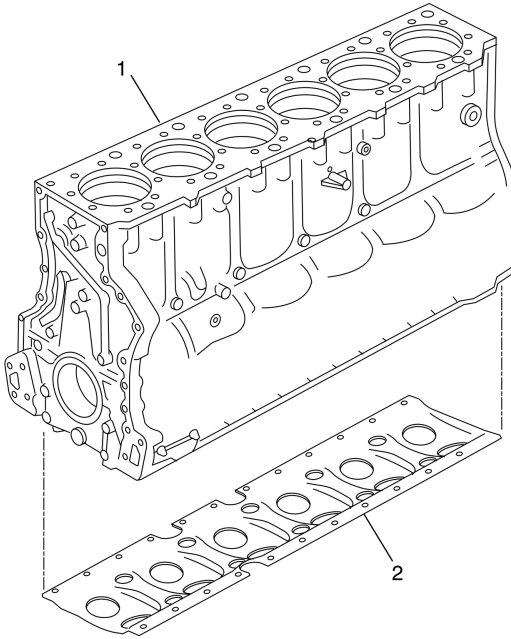

W2033309

1. Cylinder Block

2. Block Stiffener Plate

The cylinder block is made of cast iron. For increased cylinder block rigidity and noise and vibration reduction, a steel stiffener plate attaches to the bottom.

The main and piston lubricating channels are drilled longitudinally through the block. These are plugged at the front of the block. The main channel opens into a cast-in channel that supplies oil to the timing gears. The piston cooling channel is covered by the timing gear cover.

Main bearing caps are made of nodular cast iron machined together with the cylinder block. Cast alignment slots in the block and tabs on the caps ensure proper alignment at installation. Each cap is marked with its location beginning with No. 1 at the front. Cap Nos. 4 and 7 are unique and are not numbered.

The block includes cylinder liners that contact the coolant directly (wet liners). The casting shape follows the contours of the cylinders to increase rigidity and reduce noise.

Head to Block Alignment

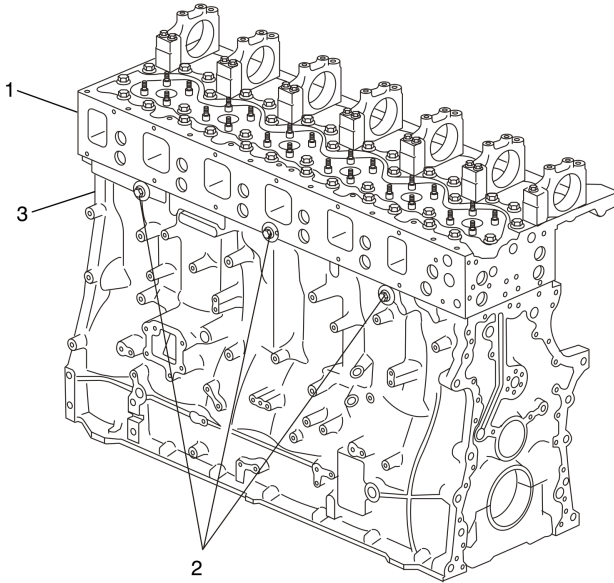

W2033310

1. Cylinder Head

3. Cylinder Clock

2. Alignment Screws and Washers

Three screws and washers installed at the side (two in the block and one in the head) align the head from side to side at assembly. Fore and aft, the head is aligned by contact with the timing gear plate.



CAUTION

The head is aligned with the timing gear plate by screws passed through the plate into the head and tightened securely. It is extremely important to remove these screws before attempting to remove the cylinder head from the block. Failure to heed this caution may result in severe damage to the timing gear plate and other engine components.

82 ENGINE COMPONENT AND LOCATION

Cylinder Head Gasket

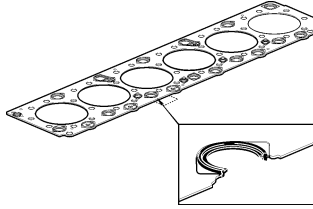

T2018766

The cylinder head gasket is made of one piece of sheet steel with vulcanized elastomer seals on oil and coolant conduits. The design of the engine and head gasket requires a unique procedure for installation of the cylinder head.

The screws and washers at the side guide the head into side-to-side alignment as it is laid on the gasket and block. Screws passed through the timing gear plate into the head pull the head into alignment fore and aft. Small, stamped bosses on the gasket hold the head clear of the seals and allow it to glide accurately into position against the plate during installation. Tightening the head bolts flattens the bosses on the gasket. For this reason, a new head gasket must be installed whenever the head is removed.

Cylinder Liner

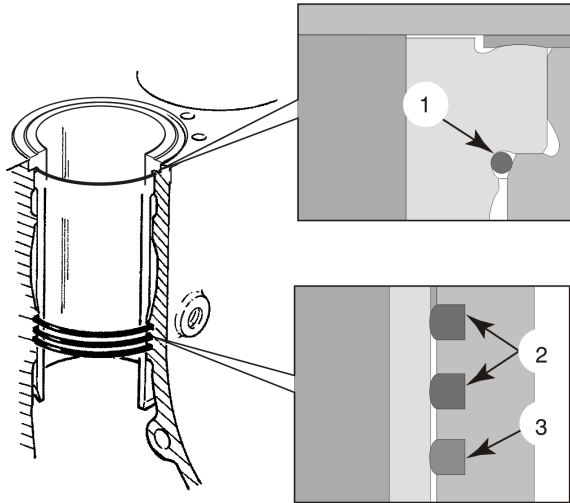

W2033311

- | | |
|--|--|
| 1. Upper O-Ring – EPDM (Black) | 3. Lower Sealing Ring – Viton (Purple) |
| 2. Middle Sealing Rings – EPDM (Black) | |

The cylinder block uses replaceable wet cylinder sleeves. The lower end of each sleeve is sealed against the block with three elastomer rings. The upper end is sealed with a ring of EPDM elastomer situated directly under the sleeve collar. This design cools the upper section of the sleeve better because the area of coolant circulation is larger.

The lower seals are fitted in grooves in the cylinder block. The bottom seal is of a different material and fluorescent violet in color to distinguish it from the intermediate seals.

84 ENGINE COMPONENT AND LOCATION

Oil Pan

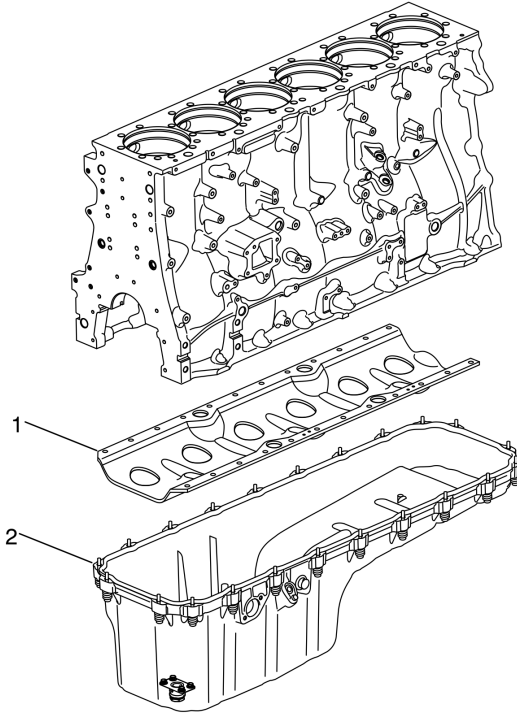

W2033312

1. Block Stiffener Plate

2. Oil Pan with Gasket

The oil pan is plastic or steel with a threaded plug for draining. The plastic pan has a groove in the mounting flange which accepts a molded elastomer gasket for a seal. The steel pan is sealed with a gasket on the oil pan flange. Twenty-two spring-loaded screws clamp the pan to the block.

The oil pan includes an oil level/temperature sensor with connector. The filler tube and dipstick mounting ports are also components of the oil pan.

Note: Oil pans with the sump at the front or at the rear are available to accommodate axle forward or axle back chassis.

Crankshaft

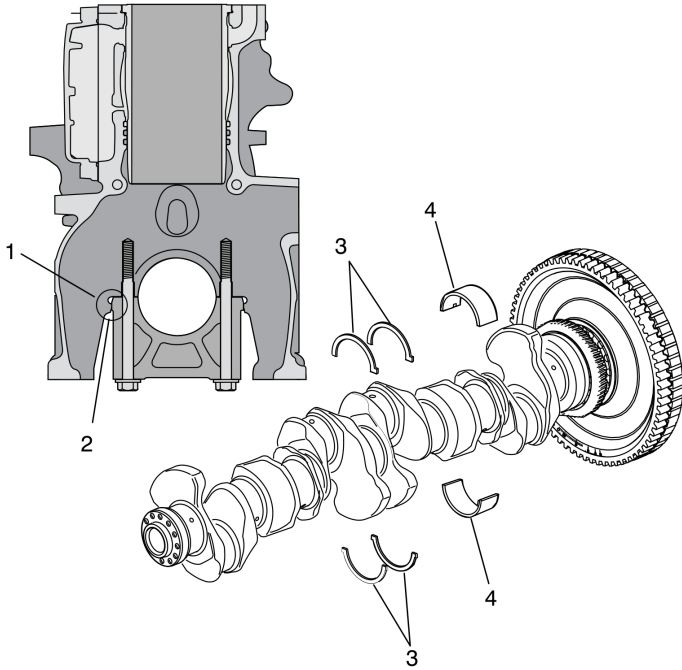

W2033313

1. Alignment Tab, Block	3. Thrust Washer
2. Alignment Tab, Cap	4. Upper and Lower Bearings

The crankshaft is drop forged steel and induction hardened. It has seven journals with replaceable bearings. Five oversized replacement bearing options are available to accommodate crankshaft regrinding.

The rear main cap (No. 7) includes an attaching point for the lube pump. Thrust washers to control axial movement straddle the central journal (cap No. 4). The remaining caps (Nos. 1–3, 5 and 6) are numbered to facilitate correct assembly.

A Teflon® seal bearing directly on the crankshaft flange is used at the front of the crankshaft. The front seal has an outer felt ring which serves as a dust cover. At the rear of the crankshaft is another seal that bears directly on the machined surface of the crankshaft gear. Additionally at the rear, there is a groove in the rear crankshaft flange for an O-ring which forms a seal between the flange and the gear.

86 ENGINE COMPONENT AND LOCATION

Piston and Connecting Rods

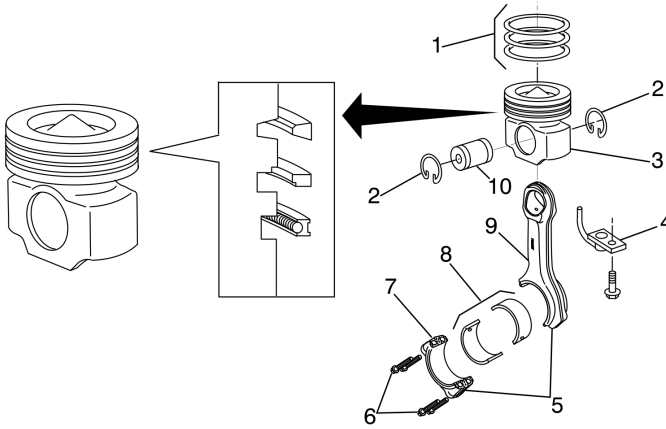

W2033314

- | | |
|--------------------|--|
| 1. Piston Ring Set | 5. Upper and Lower Connecting Rod Bearings |
| 2. Piston | 6. Connecting Rod Bearing Cap |
| 3. Wrist Pin | 7. Piston Cooling Nozzle |
| 4. Connecting Rod | 8. Assembly Matching Marks |

Connecting rods are forged steel and are used in combination with one-piece Monosteel steel pistons. The bearing caps are attached with four M12 capscrews spaced to prevent misalignment. The rods and caps are made by a "fracture" process that requires a cap be assembled with its original rod. Never attempt to use mismatched rods and caps.

The piston is fitted with three rings. In the top groove is a compression ring with a "keystone" cross section. In the second groove, the compression ring has a rectangular cross section. In the third groove is a spring-loaded oil scraper ring.

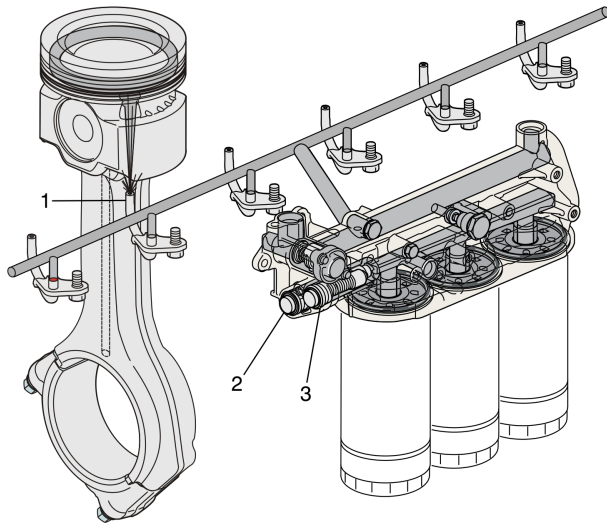

W2033316

1. Piston Cooling Nozzle

3. Opening Valve

2. Control Valve

Oil flow for the piston cooling system is controlled by two valves. The opening valve supplies oil and the control valve balances the oil flow to the piston cooling channel. The piston cooling nozzle is aligned so that the oil jet hits the underside of the piston crown.

88 ENGINE COMPONENT AND LOCATION

Timing Gears

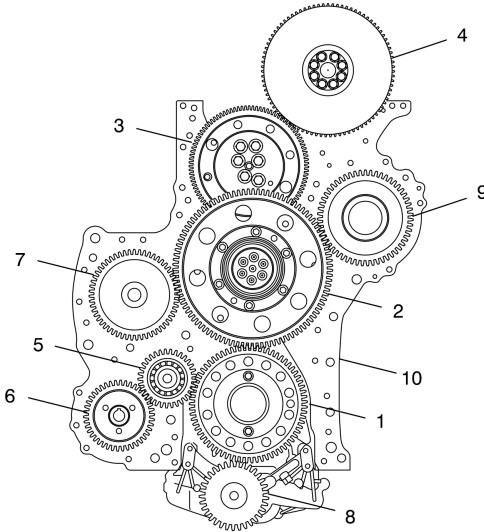

W2033318

- | | |
|-----------------------------|-----------------------------------|
| 1. Crankshaft Gear | 6. Power Steering/Fuel Pump Gear |
| 2. Double Idler Gear | 7. Air Compressor Gear |
| 3. Adjustable Idler Gear | 8. Oil Pump Gear |
| 4. Camshaft Gear and Damper | 9. Power Take-Off Gear (Optional) |
| 5. Auxiliary Idler Gear | 10. Timing Gear Plate |

The timing gears are located at the rear of the engine. Backing up the gears is a plate: a 6 mm (1/4 inch) thick steel sheet attached to the cylinder block.

The advantages of this configuration are more precise timing, fewer components and lower noise levels.

The power steering/fuel pump gear, the air compressor gear and the PTO gear are not timing gears. The pump and compressor gears fasten to their respective components. The pump gear is driven by the auxiliary idler gear. The compressor gear is driven by the double idler gear.

The double idler drives the adjustable idler and the gear used to drive the power take-off, if so equipped. This is part of the "REPTO-Ready" feature. A PTO unit with drive gear is substituted for a cover on the flywheel housing.

The camshaft gear fastens to the hub on the end of the shaft. A vibration damper also attaches to the hub outboard of the gear. Teeth on the damper actuate the camshaft position sensor. The gear is driven via the adjustable idler.

Drive Belt

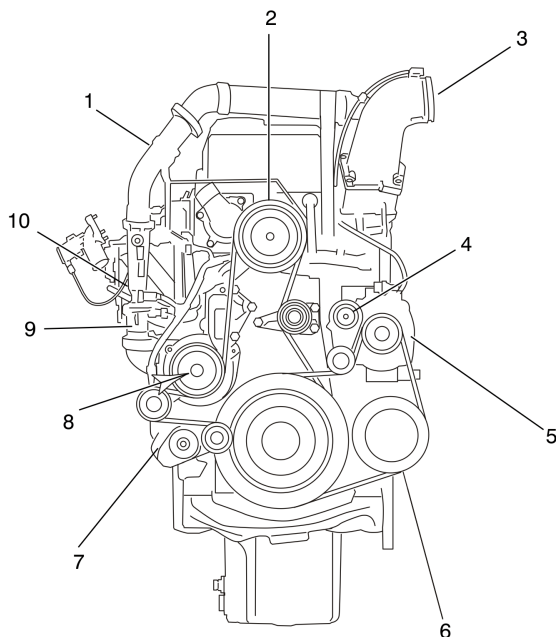

W2033321

- | | |
|--|---|
| 1. EGR Cooler Outlet Pipe | 6. Refrigerant Compressor (Pad Mount) |
| 2. Fan Drive | 7. Belt Tensioner (Fan Drive/Water Pump Belt) |
| 3. EGR Mixer | 8. Water Pump |
| 4. Belt Tensioner (Alternator/Refrigerant Compressor Belt) | 9. Venturi |
| 5. Alternator (Pad Mount) | 10. Differential Pressure Sensors |

Depending on the vehicle, the fan location may be high or low on the fan bracket.

Two poly-V belts drive the front engine accessories. The outer, primary belt (10 or 12 ribs) drives the coolant pump and fan hub from a pulley on the crankshaft flange nested in the vibration damper. The inner, secondary belt (six ribs), driven by the crankshaft vibration damper, drives the alternator and refrigerant compressor.

90 ENGINE COMPONENT AND LOCATION

Lubrication System

A gear-type pump at the rear of the engine, driven by the crankshaft gear, draws lubricant from the oil pan and supplies the system. Oil flows from the pump through the distribution housing to the filters, to a gallery at the right side of the engine serving the crankshaft journals, to a gallery at the left side serving piston lubrication and cooling, to the cylinder head and rocker shaft duct (valve rocker and camshaft) and back to the oil pan. The system includes crankcase ventilation.

Two full-flow filters and a by-pass filter maintain clean lubricant. A sensor in the oil pan monitors fluid level. There is an oil cooler immersed in engine coolant inside the coolant duct cover.

Oil Pump

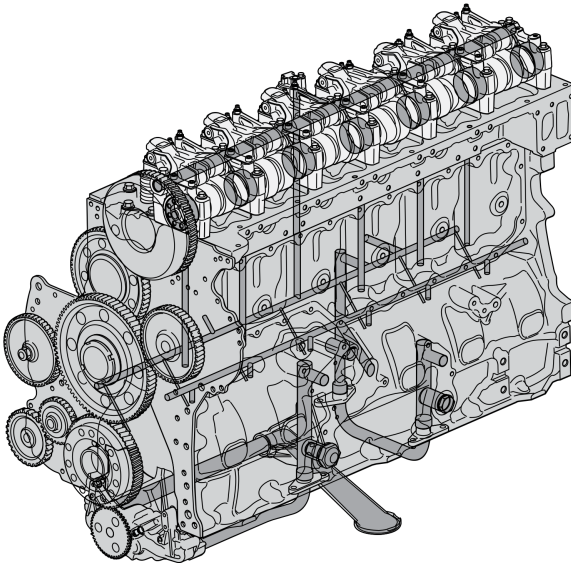

W2033324

A strainer and pickup tube lead the lubricant into the pump. For the axle forward oil pan, the strainer is mounted on a short tube held in place by a bracket attached to the distribution housing. For the axle back model, a long tube without the bracket is supplied.

Oil Flow Control and Filtration

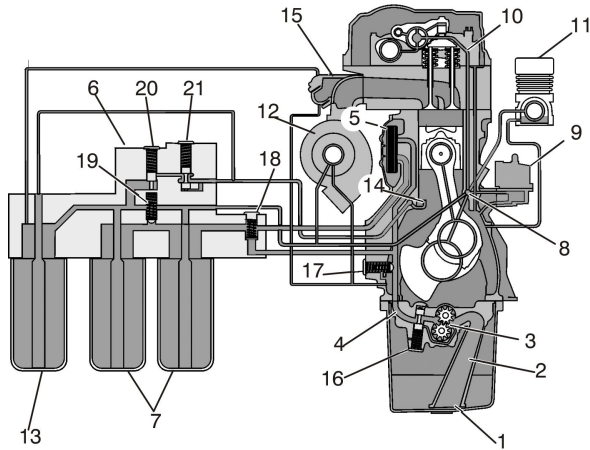

W2033325

- 1 Strainer
- 2 Pickup Tube
- 3 Oil Pump
- 4 Pressure Pipe
- 5 Oil Cooler
- 6 Filter Housing
- 7 Full-Flow Filter
- 8 Main Lubrication Gallery
- 9 CCV Separator
- 10 Exhaust brake Oil Control Valve
- 11 Air Compressor
- 12 Turbocharger
- 13 By-Pass Filter
- 14 Piston Cooling Nozzles
- 15 EGR Valve
- 16 Reducing Valve
- 17 Safety Valve
- 18 Oil Cooler Thermostat Valve
- 19 Over Flow Valve, Full-Flow Filter
- 20 Opening Valve, Piston Cooling
- 21 Control Valve, Piston Cooling

92 ENGINE COMPONENT AND LOCATION

There are three filters, one by-pass and two full-flow, attached to a housing mounted at the lower right side of the engine. Oil flow through the filters and the lubrication system is controlled by six valves, including:

- Reducing Valve
- Safety Valve
- Oil Cooler Thermostat Valve
- Overflow Valve, Full-Flow Filter
- Opening Valve, Piston Cooling
- Control Valve, Piston Cooling

The reducing valve maintains constant system oil pressure. The safety valve prevents excessive pressure during periods of high viscosity. The oil cooler thermostat valve prevents oil from entering the cooler until it warms to the set point. The overflow valve allows oil to by-pass the filter if it becomes clogged. The opening valve prevents oil from moving to the piston cooling outlets until the system reaches the set pressure. The control valve regulates the oil flow to the piston cooling channels.

Crankcase Ventilation

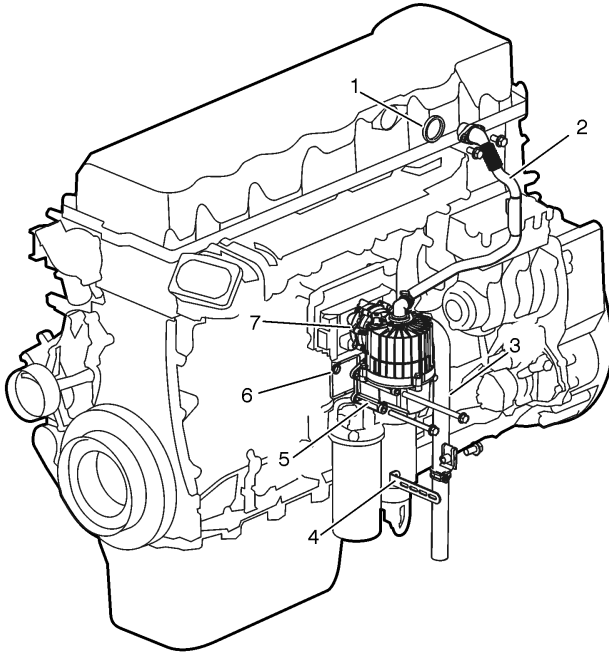

W2033326

- | | |
|-------------------------|-----------------------|
| 1. Seal Ring | 5. Separator Housing |
| 2. Separator Inlet Hose | 6. Housing Seal |
| 3. Separator Vent Tube | 7. Pressure Regulator |
| 4. Vent Tube Bracket | |

94 ENGINE COMPONENT AND LOCATION

Lubricant becomes a mist in many areas of the engine as the result of the motion of the parts (e.g., rocker arms, pistons, crankshaft, camshaft and rocker shaft). The mist rides the drafts of air and other gases that circulate in the open spaces in the engine. To prevent pressure buildup, the open spaces are ducted through a pipe that opens to the atmosphere near the bottom of the engine.

The crankcase ventilation (CCV) system separates the oily mist from the gases by centrifugal force. The oil returns to the oil pan. The remainder escapes to the atmosphere.

A turbine in the CCV separator, driven by a small stream of oil striking its fins, spins at high speed. The mixture of gases and oily mist trapped in the valve cover and the timing gear cover drains onto the top of the center of the turbine and runs down onto several discs rotating with the turbine. Separation occurs as the mixture, flung outward by the turbine, strikes the walls of the CCV. The droplets of mist coalesce into a liquid and drain back into the oil pan along with the oil that drives the turbine. The gases are free to leave via an open port.

The open port connects to a tube leading to the bottom of the engine where road draft draws the gases into the atmosphere.

Fuel System

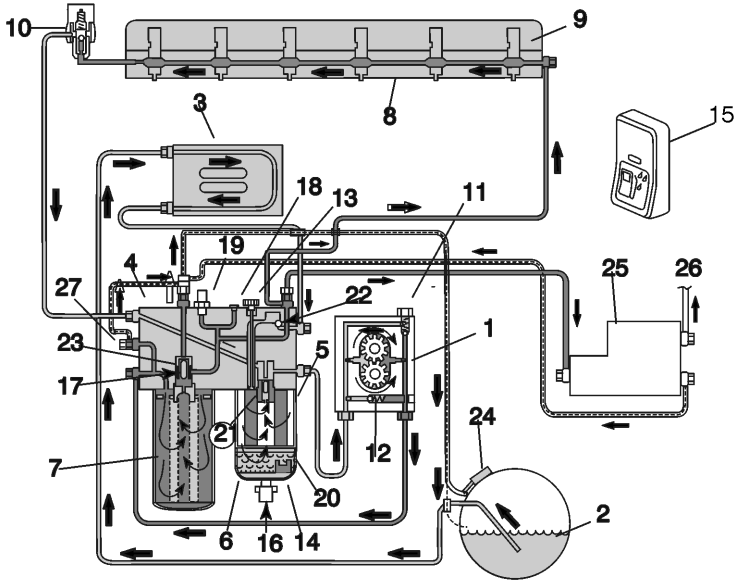

96 ENGINE COMPONENT AND LOCATION

1 Fuel Pump	16 Electrical Water Drain Valve
2 Fuel Tank and Inlet Tube	17 Automatic Air Bleed Valve (closes when filter removed)
3 EECU Cooler	18 Service Port (Pressure Gauge)
4 Fuel Filter Housing	19 Supply Pressure Sensor
5 Fuel Pre-Filter	20 Fuel Heater (Optional)
6 Water Cup	21 Service Shut-Off Valve (closes when filter removed)
7 Secondary (Main) Filter	22 One-Way Valve (Hand Priming)
8 Fuel Gallery	23 Automatic Bleed Valve
9 Unit Injector	24 Fuel Tank Breather
10 Pressure Regulator Valve	25 AFI Shut-Off Valve
11 Pump Safety Valve (Pressure Regulator)	26 Line to AFI
12 One-Way Valve	27 Deaeration Valve
13 Hand Pump Handle	
14 Water Level Sensor	
15 Water Discharge Control Switch (Instrument Panel)	

The fuel pump attaches with the power steering pump to the flywheel housing at the rear left side. It turns on the same shaft as the power steering pump. The common drive gear meshes with the auxiliary idler driven by the crankshaft gear. At 600 rpm, the pump delivers a minimum 100 kPa (14.5 psi), and at 1200 rpm, 300 kPa (43.5 psi). At 400–550 kPa (58?80 psi), the gallery regulator valve opens to control fuel gallery pressure.

Fuel is drawn by the pump from the tank into the EECU cooling plate and the primary filter at the left side of the engine and on to the pump inlet. Under pressure, fuel then flows from the pump to the secondary filter and the fuel gallery in the cylinder head. Fuel pressure within the gallery is controlled by a pressure regulator valve which returns excess fuel to the tank.

Fuel Filtration

Primary and secondary filter elements attach to the underside of the filter valve housing. The housing, located at the front lower left side of the cylinder block, has an integral hand-priming pump for bleeding the system. The 30 micron pre-filter (primary filter) also separates water from the fuel. Water collects in a cup on the bottom of the pre-filter. There is a sensor to keep track of the water and signal the EECU.

Note: The collected water can be dumped only while the engine is not running, the key is in the ON position and the parking brake is set.

A check valve prevents fuel from draining back to the fuel tank when the engine is shut down. Also included in the valve housing is the fuel pressure sensor just above the primary filter.

Unit Injectors

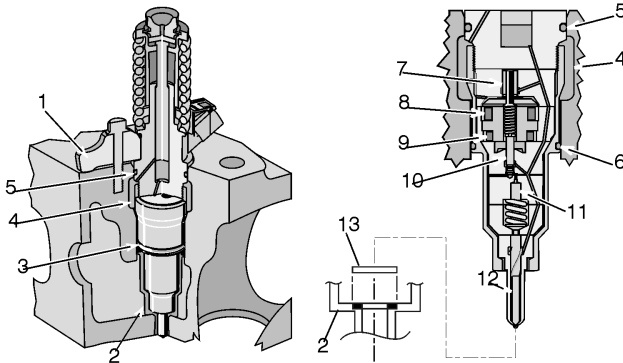

W2033328

- | | |
|--------------------------|---------------------|
| 1. Injector Yoke | 8. Solenoid Coil |
| 2. Copper Sleeve | 9. Solenoid Coil |
| 3. O-Ring | 10. Injector Valve |
| 4. Fuel Gallery | 11. Injector Piston |
| 5. O-Ring | 12. Injector Nozzle |
| 6. O-Ring | 13. Washer |
| 7. Pressure Relief Valve | |

This engine uses double solenoid unit injectors. Unlike systems that require separate components for delivering, pressurizing and injecting, this unit injector combines these functions. These injectors precisely control the fuel delivery because of the two solenoids. The solenoids, pump and nozzle are in a single body in close proximity to each other.

The injector is set in a pressurized fuel gallery where the fuel temperature is constant. Uniform fuel temperature means uniform quantity in each injection which means uniform power output from each cylinder.

The fuel pump pressurizes the gallery so that fuel rushes into each injector when it opens. Gallery pressure is regulated by a valve that delivers excess fuel back to the tank.

Copper sleeves, acting as coolant jackets, line the bottoms of the injector bores. Engine coolant circulates around these sleeves aiding the process of controlling injection temperature.

There are four phases to the injector cycle of operation. These include:

- Fill phase
- Spill phase
- Injection phase
- Pressure drop phase

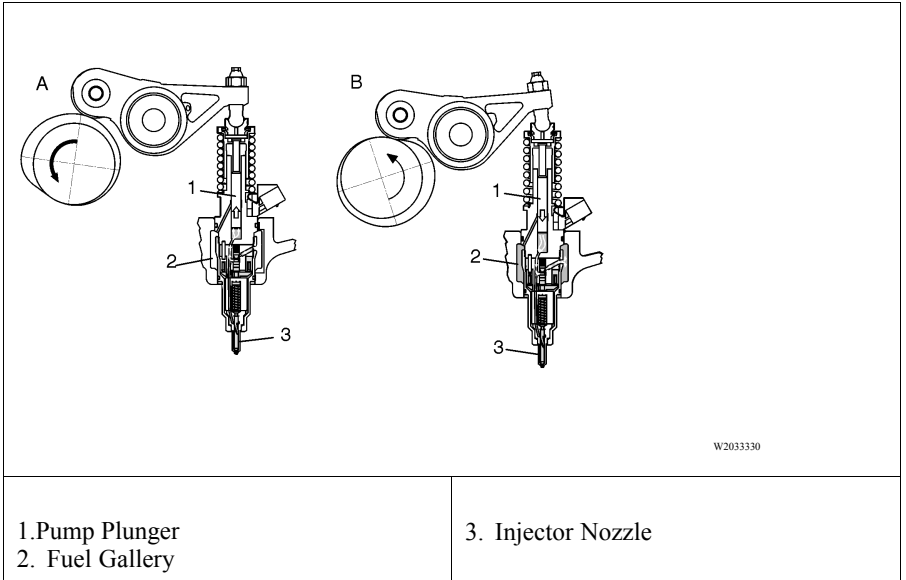

Fill phase (A): During the filling phase, the pump plunger is on its way up, the camshaft lobe is passing its highest point and the rocker arm is on its way toward the camshaft base circle. The fuel valve is open, allowing fuel to flow into the unit injector from the lower fuel gallery. Fuel flows into the cylinder head and the unit injector pump cylinder. Filling continues until the pump plunger reaches its upper position.

Spill phase (B): The spill phase begins when the camshaft lobe forces the rocker arm to push the pump plunger down. The fuel can now flow through the fuel valve, through the holes in the unit injector and out through the fuel gallery. The spill phase continues as long as the fuel valve is open.

100 ENGINE COMPONENT AND LOCATION

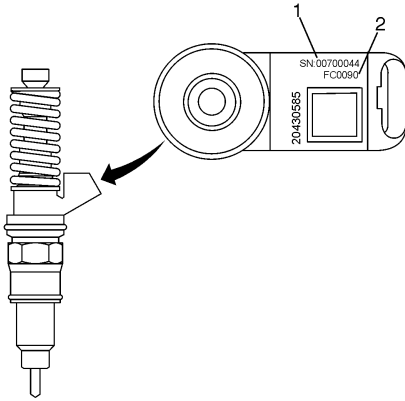

W2033335

1. Serial No.

2. Unit Calibration No.

Unit injectors are categorized and coded with regard to tolerances. Whenever a unit injector is replaced, the replacement injector **MUST** be programmed for the cylinder in which it is installed. This is done by programming EECU parameters using the VCADS pro or the Premium Tech Tool (PTT) to set Injector Trim parameters with the trim codes marked on the injectors.

Note: The dimension by which the injector nozzle extends from the head is critical. This means that machining the head in any way that changes this nozzle extension is not permitted.

Volvo Engine Brake

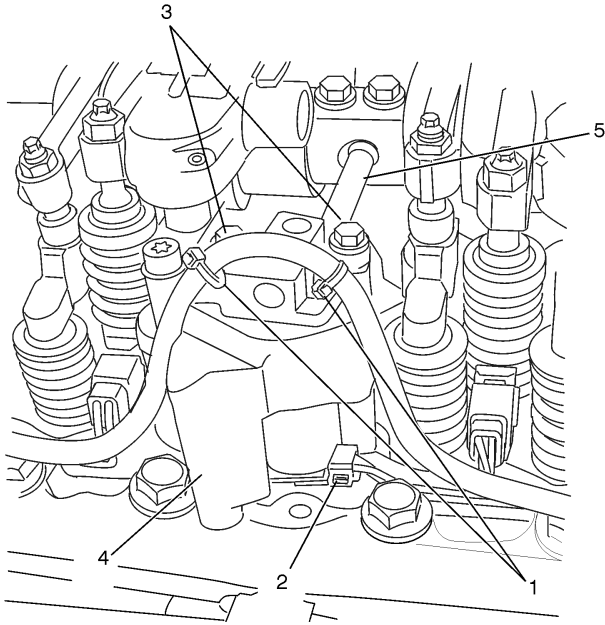

W2033356

- | | |
|-------------------------|--------------------------|
| 1. Tie Wraps | 4. Solenoid |
| 2. Electrical Connector | 5. Tube — Valve to Shaft |
| 3. Attaching Screws | |

102 ENGINE COMPONENT AND LOCATION

The engine can be equipped with a Volvo engine brake system to assist in slowing the vehicle when necessary. The system includes the:

- Wiring harness
- Camshaft
- Oil control valve
- Exhaust rocker arms
- Engine brake rocker arms
- Exhaust valve yokes (bridges)

There is a separate cam on the camshaft at each cylinder for the engine brake rocker arm. The lobes on this cam are timed to coordinate with the lobes on the exhaust valve cam.

The exhaust rocker arm operates normally. When engaged, the engine brake rocker arm also operates the exhaust rocker arm. It causes the valve to open in a strategy to decrease cylinder power output. Engine power is reduced assisting the brakes in slowing the vehicle.

The engine brake rocker arms are equipped with a blade spring which keeps the rollers in contact with the cams.

Volvo Engine Brake operation depends on all of the following conditions which must exist simultaneously.

- Accelerator pedal released
- Engine speed above 1100 rpm
- Clutch pedal released
- Road speed above 5 km/h (3.1 mph)
- ABS inactive
- Transmission in gear
- Oil temperature above 55°C (131°F)
- Charge air pressure above 50 kPa (7.25 psi)

On the cylinder head, the oil control valve connects the oil passages in the head and rocker shaft. The oil pump produces constant pressure at this junction. While the accelerator pedal is depressed, the control valve reduces the oil pressure in the rocker shaft to a minimum 100 kPa (14.5 psi).

When the accelerator pedal is released (and the Volvo Engine Brake switch is ON), the solenoid opens allowing some oil to escape through a small port. Reduced spring pressure moves the piston, opens the passage to the rocker shaft and increases the oil pressure. The system opens the exhaust valve during induction and again immediately before TDC on the compression stroke.

The engine slows because the extra volume under compression takes more power to compress, and escaping pressure in the combustion stroke reduces the power output. A switch on the instrument panel allows the driver to engage or disengage Volvo Engine Brake.

If the ABS system becomes active, it automatically disables Volvo Engine Brake. If the oil temperature goes below 55°C (131°F), Volvo Engine Brake cannot be activated. A warning lamp on the instrument panel flashes if the driver attempts to activate it under this condition.

A port in the cylinder head allows access to the oil passageway. The plug can be removed and a gauge inserted for use during diagnostic procedures.

System Oil Pressure		
Engine Speed/RPM	Temperature	Pressure
600	90 – 110°C (195 – 230°F)	>250 kPa (>36 psi)
>1100	90 – 110°C (195 – 230°F)	300 – 550 kPa (44– 80 psi)
>1100	Cold Engine	650 kPa (95 psi)

Rocker Shaft Engine Brake	Engine Speed/RPM	Oil Pressure
Active	900 — 2300	220 kPa (32 psi)
Inactive	—	80 — 120 kPa (12 — 17 psi)

Exhaust Gas Recirculation System

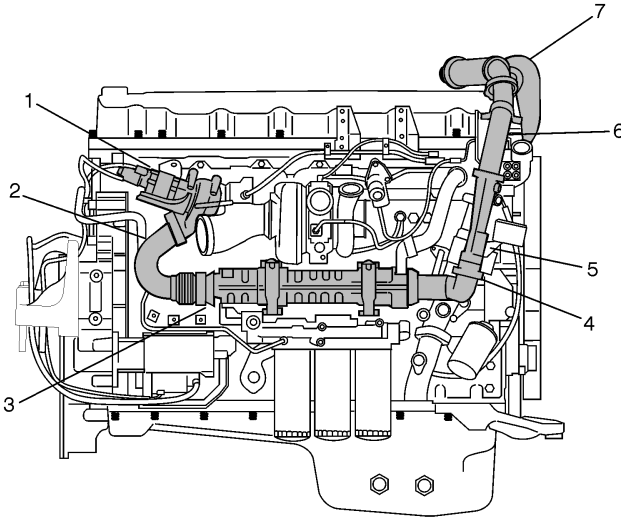

W2033359

- | | |
|--------------------------|----------------------------------|
| 1. EGR Valve | 5. Differential Pressure Sensors |
| 2. EGR Cooler Inlet Pipe | 6. EGR Cooler Outlet Pipe |
| 3. EGR Cooler | 7. EGR Mixer |
| 4. Venturi | |

Nitrous oxide (NO_x) emission levels increase with combustion temperature. The primary function of the Exhaust Gas Recirculation (EGR) system is to cool exhaust gas and send it back to the combustion chamber to lower the combustion temperature thereby to reduce NO_x emissions.

The mixer where the recirculated exhaust joins the inlet air, mounts at the front of the inlet manifold for the conventional chassis engines.

EGR Valve

This engine uses the EGR valve to recirculate exhaust gases. Engine oil operates the EGR valve. The EECU determines the desirable valve opening based on inputs from a number of sensors and commands the EGR valve solenoid to open or close the valve.

Corrosion occurs in the inlet manifold if exhaust gas condenses there. This can produce both internal and external damage. To eliminate corrosion, the EECU compares engine RPM, torque load, ambient temperature, inlet manifold temperature and EGR demand to calculate the dew point in the inlet manifold. It then adjusts the EGR opening to stay above the dew point. Additionally, surfaces within the inlet manifold and the mixing chamber are treated to resist corrosion.

The EGR valve attaches to the rear section of the exhaust manifold for reliable response and turbocharger efficiency. This location also protects the EGR cooler from harmful high pressure exhaust pulses that occur during engine braking.

EGR Valve Function

When the EGR valve is open, exhaust gas recirculates into the combustion chamber. The valve is normally closed when engine coolant temperature is below 65°C (149°F) unless the EECU commands the valve open during automatic cooler cleaning mode. When coolant temperature exceeds 65°C (149°F), engine load exceeds 50%, and RPM exceeds 1200, the EECU opens the EGR valve to approximately 90% of its range.

At idle, the EECU monitors exhaust temperature every three minutes. If it exceeds 98°C (208°F), the valve opens to approximately 14% of its range. Otherwise, it remains closed.

106 ENGINE COMPONENT AND LOCATION

EGR Cooler Inlet Pipe

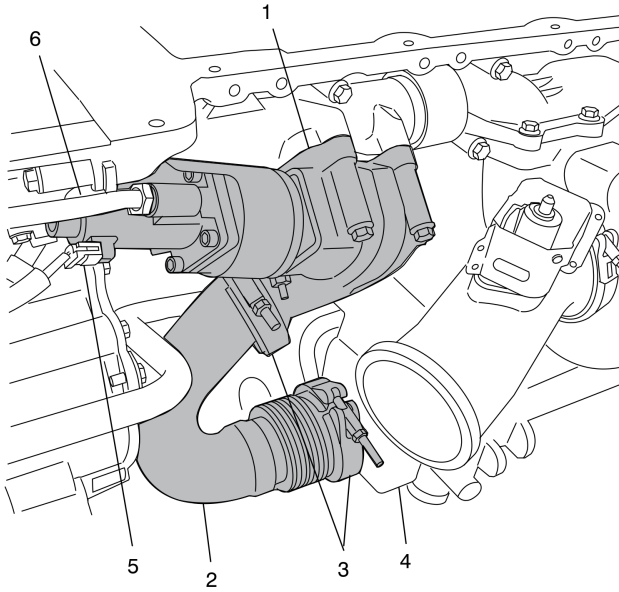

W2033358

- | | |
|----------------------|-------------------------|
| 1. EGR Valve | 4. EGR Cooler |
| 2. Cooler Inlet Pipe | 5. Electrical Connector |
| 3. Clamps | 6. Oil Supply Line |

The cooler inlet pipe conducts the exhaust from the EGR valve to the EGR cooler. The cooler lowers the exhaust stream temperature before it reenters the combustion chamber.

EGR Cooler

The EGR valve is connected to the EGR cooler by the cooler inlet pipe. Using engine coolant, the EGR cooler lowers the temperature of the gas coming from the EGR valve. The cooler contains a series of vanes that increase cooling efficiency by swirling the hot gas before it enters the mixer.

EGR Venturi System

On leaving the EGR cooler, the gas flows through a venturi equipped with two pressure sensors. The venturi changes the speed and density of the flow. The sensors report the pressure difference to the EECU.

EGR Cooler Outlet Pipe

The EGR cooler outlet pipe carries the exhaust gas from the venturi to the mixer. Relatively short, the tube passes over the valve cover, behind and into the mixer at the front end of the inlet manifold on the conventional chassis engine.

Relatively much longer on the LCF, the tube passes from the venturi around the front of the valve cover and reaches back to the mixer at the rear end of the inlet manifold.

A temperature sensor monitors exhaust temperature sending the data to the EECU. Excessively high temperature, or abnormally high temperature for more than 30 minutes during an hour, causes the EECU to limit engine power to prevent engine damage.

EGR Mixer

The EGR mixer is the meeting point for cooled, recirculating exhaust gas and outside air from the CAC. From here, the combined gases pass into the inlet manifold and on to the combustion chamber.

108 ENGINE COMPONENT AND LOCATION

Inlet Air Heater

The optional inlet air heater mounts between the mixer and the inlet manifold. It is activated when the operator turns the key to the preheater position and the engine coolant temperature is lower than 10°C (50°F).

Operating time is controlled by the EECU. The operating relay is mounted on the inlet manifold. A lighted icon on the instrument panel signals when the element is On.

EGR Diagnostics

The EECU commands the EGR valve position and monitors electric current consumed by the EGR valve. An abnormally high reading indicates a jammed EGR valve. The EECU verifies that its command was sent and that the valve position reflects the command. If the valve is jammed, or its position doesn't change when commanded, the EECU sets fault codes.

A degraded EGR cooler results in low efficiency. The EECU calculates efficiency by comparing EGR gas temperature with engine coolant and exhaust temperatures. An EGR cooler clogged with soot also causes a fault code to be set.

Air Intake System

Fresh air enters the intake above the back of the cab. Plastic duct work leads the air to the filter assembly mounted on the bulkhead under the hood. An impregnated paper filter prevents foreign particles from passing through. The assembly design permits the addition of a second filter if needed in extreme environments.

A combination pressure/temperature sensor mounted on the pipe between the filter housing and the turbocharger alerts the driver if the filters need replacement prior to the schedule service. The brake system air compressor also draws fresh, clean air from this same page.

Variable Geometry Turbocharger

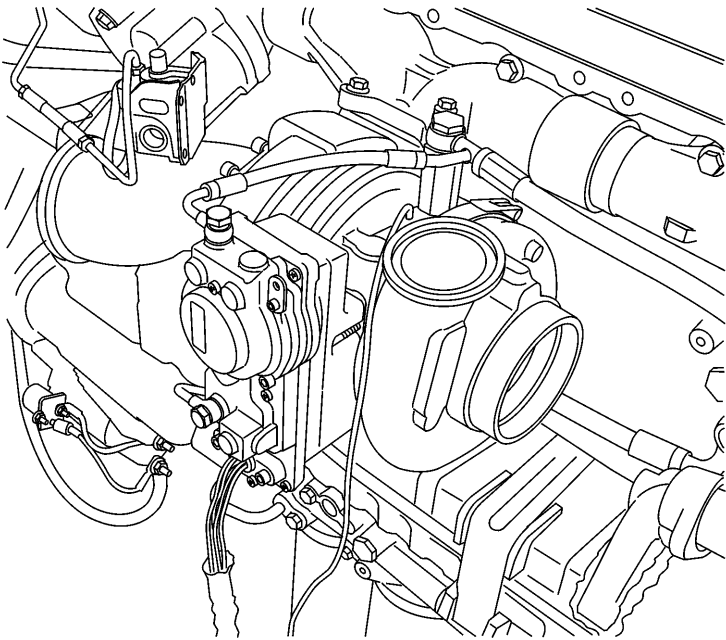

W2033362

The engine is equipped with a variable geometry turbocharger. The turbine housing has a set of vanes and a sliding nozzle ring that maintains sufficient back pressure in the exhaust manifold for proper operation of the EGR system. A certain amount of back pressure is required to push the exhaust gases into the pressurized intake air at the EGR mixer.

110 ENGINE COMPONENT AND LOCATION

Cooling System

The cooling system incorporates a belt-driven coolant pump mounted on the front of the engine on the right. It also uses a piston-type thermostat housed in the front of the cylinder head and a fan with viscous or air-operated drive mounted above the crankshaft pulley. A coolant conditioner (filter) attached to the pump housing filters impurities from the coolant and releases supplemental coolant additives for system protection.

Coolant Pump

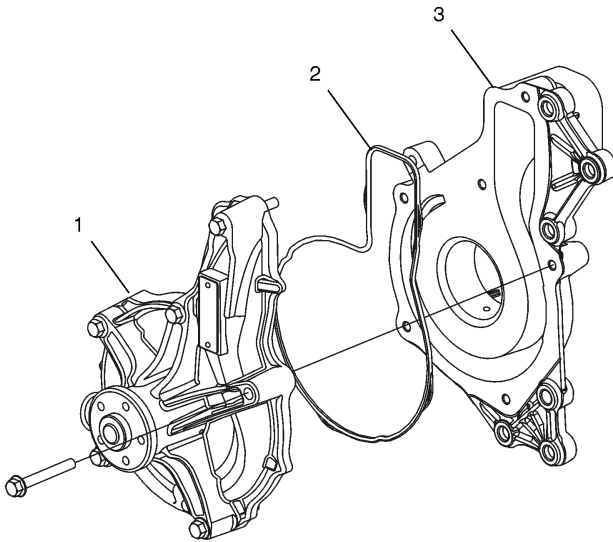

W2033363

1. Impeller Housing

3. Coolant Pump Mounting Plate

2. Coolant Pump Seal

The back of the coolant (water) pump, with its ducts for distributing coolant, is a separate casting attached to the cylinder block.

A housing containing an impeller, shaft seals, bearing and pulley attaches to the mounting plate. The bearing is a permanently lubricated combination roller and ball bearing. Between the shaft seals and the bearing, there is a ventilated space which leads into a duct behind the pulley. This allows internal leaks to be detected.

Thermostat

This is a piston-type, full-flow thermostat with piston, bulb, seal and housing in a single assembly. Coolant flows continuously, either back to the pump, or to the radiator and back to the pump. It has lower pressure drop compared to other types. The thermostat is mounted on the front of the cylinder head.

Engine Cooling Fan

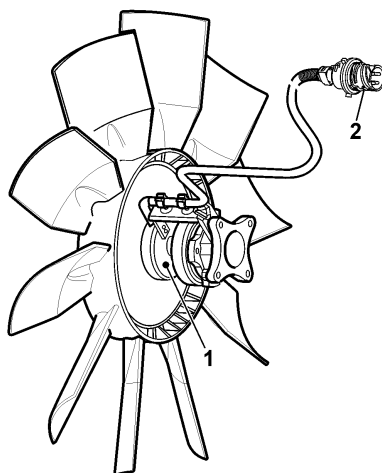

T2019149

1. Solenoid Valve and Speed Sensor	2. Connector (to EECU)
------------------------------------	------------------------

The cooling fan runs via a viscous or air-operated drive through which fan speed is electronically controlled by the EECU. With precise EECU control, fan speed is continuously adjusted in response to several interrelated influences. This makes for efficient cooling with low fuel consumption.

112 ENGINE COMPONENT AND LOCATION

Engine Managment System

Engine Electronic Control Unit (EECU)

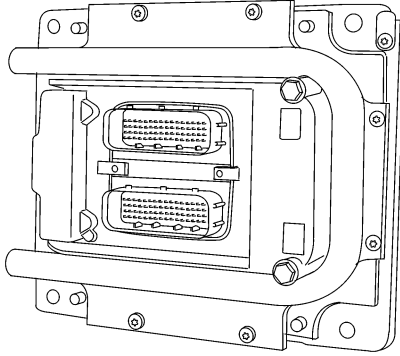

W2033364

The engine management system module, also known as the Engine Electronic Control Unit (EECU), is located on the left side of the engine just below the inlet manifold. The EECU is cooled by fuel circulating through a plate attached to the cover of the unit. The fuel comes from the tank on its way to the fuel pump.

Algorithms, called maps, are programmed in the EECU so that it can translate sensor data into action. These maps enable the EECU to receive status information from the sensors and send functional data to the actuators so they can simultaneously assume the proper posture for the safest, most efficient operation of the engine in any given instant.

Due to the EECU self-learning capability, it is necessary to reset the learned EECU parameters after servicing some engine-related components. This allows the EECU to learn the new component's behavior. After servicing is complete, perform the "Learned Data Reset" located in the Function Group 1 menu on the PC tool.

Exhaust Aftertreatment System

New, stringent standards for exhaust emission control begin with the 2007 model year. The Exhaust Aftertreatment System (EATS) has been developed to act in combination with Ultra Low Sulfur Diesel (ULSD) fuel and the EGR system to reduce noxious emissions to meet the requirement. This new system treats the exhaust after it leaves the turbocharger on its way to the atmosphere.

Exhaust Gas Recirculation

Nitrous oxide (NO_x) emission levels increase with combustion chamber temperatures. The primary function of the Exhaust Gas Recirculation (EGR) system is to cool exhaust gas and recirculate exhaust gases back to the combustion chamber to lower the combustion temperature, thereby reducing nitrous oxide (NO_x) emissions.

Reducing the quantity of noxious compounds to an acceptable level beginning in the year 2007 requires altering their chemical composition. Directing the flow of exhaust gas through catalytic and particulate filters makes this happen.

Particulate Matter

The compounds remaining in the exhaust after passing through the EGR system contain extremely small particles of soot and ash called Particulate Matter (PM). When these particles contact certain metals under high temperature, they are chemically transformed. The metals that cause this transformation are called catalysts.

Catalytic Filters

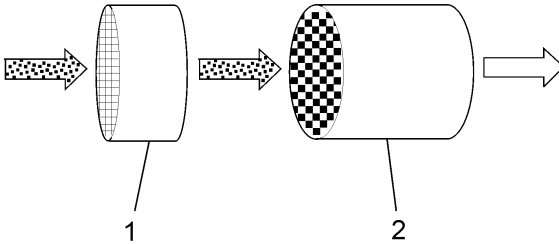

W2033360

1. Diesel Oxidation Catalyst

2. Catalyzed Diesel Particulate Filter

A catalytic filter (converter) is a porous form (like a sponge) that has been coated with a catalytic material. The flow of exhaust gas must pass through the pores on its way to the atmosphere. As a result, a high percentage of the PM is transformed.

Diesel Oxidation Catalyst

A catalytic filter, the diesel oxidation catalyst (DOC) reduces emissions in diesel exhaust by an average of approximately one third over a system without a DOC. Its honeycomb-like structure (called substrate) is coated with an active catalyst. The PM is changed to carbon dioxide and water. The substrate can be made of a wide range of materials. Ceramic (cordierite) and sintered metal are common.

Some PM usually remains unconsumed by the heat and collects on the filter. Eventually, the filter must be taken out to remove the accumulated residue by other means. There is a special machine to do this cleaning.

Diesel Particulate Filter

Basically a trap, a diesel particulate filter (DPF) collects the soot and ash to hold until they can be burned off. A catalyzed DPF also transforms unburned fuel, engine lubricant and carbon monoxide into carbon dioxide and water.

Depending on vehicle vocation, the operating temperature of the exhaust may or may not be sufficient to consume the trapped soot and ash. If necessary, a means of elevating the temperature is included in the system.

Filter Regeneration

Cleaning a filter so it can continue to function is called "regeneration." High heat with a catalyst breaks down the chemical properties. Depending on the vehicle usage, the engine will be equipped with a passive or an active regeneration system.

As with any filter, eventually the DOC and the DPF will become clogged. Rising back pressure caused by plugging the exhaust system decreases fuel economy and reduces engine efficiency. It is necessary to clean these filters from time to time.

The filters can be regenerated to continue in use. The high temperature needed to complete the process exists in the exhaust itself. Because some vehicle vocations do not allow the exhaust temperature to rise to, or continue at, adequate levels, a device to control the temperature is included.

Passive Regeneration

For vehicles that produce and maintain adequate exhaust temperature, the soot and ash are consumed at a rate that prevents clogging the filter prematurely. Setting a DOC ahead of the catalyzed DPF in the exhaust stream reduces the temperature required to regenerate the filters.

However, the process is not complete. Eventually, the filter must be taken out to remove the accumulated residue by other means.

116 ENGINE COMPONENT AND LOCATION

Active Regeneration

For vehicles that are unable to develop or sustain adequate temperature, there is more than one system for supplying sufficient heat.

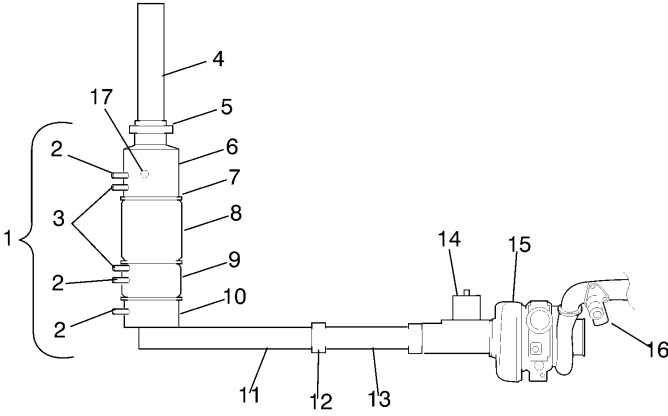

W2033245

- 1 DPF Muffler
- 2 Temperature Sensor
- 3 Differential Pressure Sensor
- 4 Stack Pipe
- 5 Pipe Clamp
- 6 Outlet Module
- 7 Clamp
- 8 Filter
- 9 Catalyst
- 10 Inlet Module
- 11 Exhaust Pipe
- 12 Hose Clamp
- 13 Flex Pipe
- 14 Aftertreatment Fuel Injector
- 15 Turbocharger
- 16 Discharge Recirculation Valve
- 17 NOx Sensor

An aftertreatment fuel injector (AFI) (Figure above), adds fuel to the exhaust stream as it leaves the turbocharger. The temperature of the exhaust at this point is hot enough to ignite the fuel which then produces the temperature required to clean the filters. If needed, the discharge recirculation valve (DRV) reroutes some of the turbocharger output back through the turbocharger. This helps to maintain high exhaust temperature. The engine electronic control unit (EECU) controls the cycle based on information from back pressure sensors in the output stream. While the flow rate is correct, the AFI and the DRV are turned off.

As with passive regeneration, the process is not complete. Remove the filters and physically remove the remaining material using the special machine for cleaning. The filters are reusable.

Manual Regeneration

A procedure called "Manual Regeneration" can be used to regenerate the filters while they remain in the vehicle. The VCADS service tool or the Premium Tech Tool (PTT) can be used to perform this function.



WARNING

The exhaust system reaches extremely high temperatures. Ensure that the system components are clear of all combustible materials. Ensure that personnel are aware that the surfaces are extremely hot. Failure to heed this warning may result in severe personal injury and property damage.

Discharge Recirculation Valve

The Discharge Recirculation Valve (DRV) redirects some of the turbocharger output back through the turbocharger. This results in elevated exhaust temperature.

The EECU uses this feature to maintain adequate exhaust temperature in support of active regeneration in the DPF system.

Ultra Low Sulfur Diesel Fuel

A catalyst works better the higher the temperature up to about 400°C (750°F). Above this temperature, sulfur can become sulfuric acid. These filtering systems are practical only on vehicles that use ultra low sulfur fuels. It is required that diesel engines operating in conjunction with a DPF system use ultra low sulfur fuel that contains 15 parts per million (ppm), or less, of sulfur.

Operational Mode

The exhaust aftertreatment system (EATS) usually operates in one of five modes.

Normal Mode

Heat Mode

Passive Regeneration Mode

Active Regeneration Mode

Service Mode

In the Normal Mode, the engine is controlled by its regular calibration. However, the filters can be self-cleaning through passive regeneration. Heat Mode indicates that active regeneration is in process. In Passive Regeneration Mode, the engine creates sufficient exhaust temperature to convert the gases and regenerate (clean) the filters. In Active Regeneration Mode, exhaust temperature is artificially raised for short periods of time to convert the gases and clean the filters. The applicable controller reacts to data from back pressure sensors to start and stop the active regeneration process. A system in Service Mode is being inspected for accumulation of soot and ash in the filters to determine whether they should be manually regenerated or removed for external regeneration.

120 ENGINE COMPONENT AND LOCATION

DPF System Vehicle Mounting

The DPF system is either a vertical back-of-cab (VBOC) DPF unit with muffler for the conventional chassis or a compact unit DPF unit with muffler to accommodate the low cab forward chassis. The space saver unit attaches to the outside of the right rail under the cab. Either of these connects to the engine exhaust system behind the turbocharger.

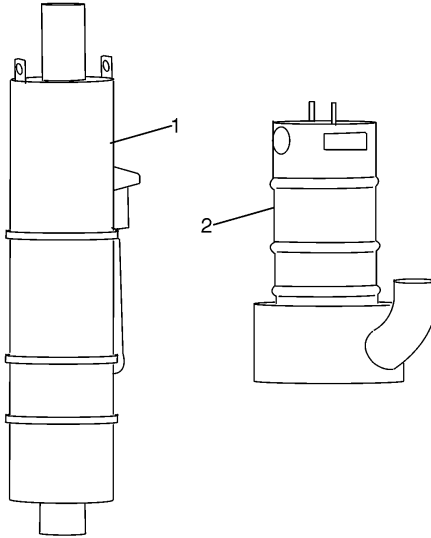

W2033361

1. Vertical Back-of-Cab Unit

2. Space Saver/Compact Unit

COMPONENT PART NUMBER LOCATOR

Engine, Right-Side View

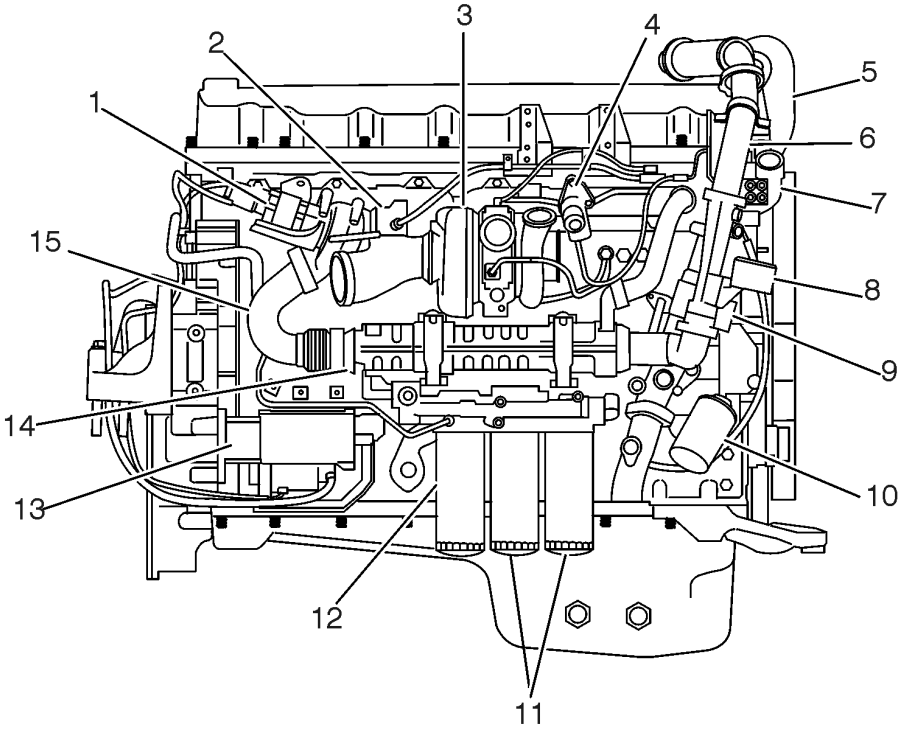

122 ENGINE COMPONENT AND LOCATION

Description	Part Number
1. EGR Valve	1. 85111067
2. Aftertreatment Fuel Injector	2. 21082971
3. Variable Geometry Turbo	3. Check per VIN number
4. Discharge Recirculation Valve	4. 20940438
5. EGR Mixer	5. 21033737
6. EGR Coolant Outlet Pipe	6. 20900934
7. Thermostat Housing	7. 20560249
8. Differential Pressure Sensors	8. 20930137
9. Venturi	9. 21012484
10. Coolant Conditioner	10. 20458771 (per VIN number)
11. Full Flow Oil Filters	11. 478736
12. Bypass Oil Filter	12. 477556
13. Starter	13. Check per VIN number
14. EGR Cooler	14. 85111060
15. EGR Cooler Inlet Pipe	15. 20966374

All part numbers are for reference only, you should always refer to truck BOM's before ordering parts.

Engine, Left-Side View

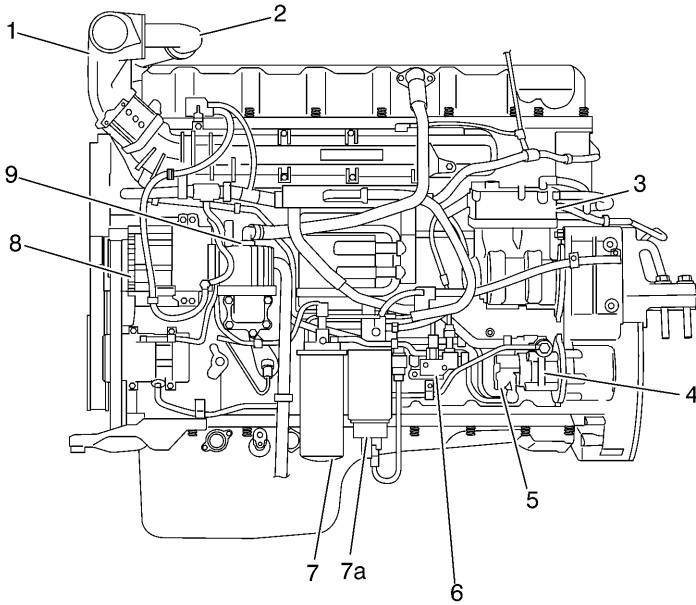

W2032501

Description	Part Number
1. EGR Mixer	1. 21033737
2. EGR Cooler Outlet Pipe	2. 20900934
3. Air Compressor	3. Single Cyl. 85116641 Dual Cyl. 85116642
4. Power Steering Pump	4. Check per VIN number
5. Low Pressure Fuel Pump	5. 85111130
6. DPF Fuel Control Valve	6. 20942984
7. Secondary Fuel Filter	7. 20972293
7A. Primary Fuel Filter	7A. 20879806
8. Alternator (Pad Mount)	8. 20487081
9. CCV Separator	9. 20499419

Note: All part numbers are for reference only, you should always refer to truck BOM's before ordering parts.

124 ENGINE COMPONENT AND LOCATION

Engine, Front View

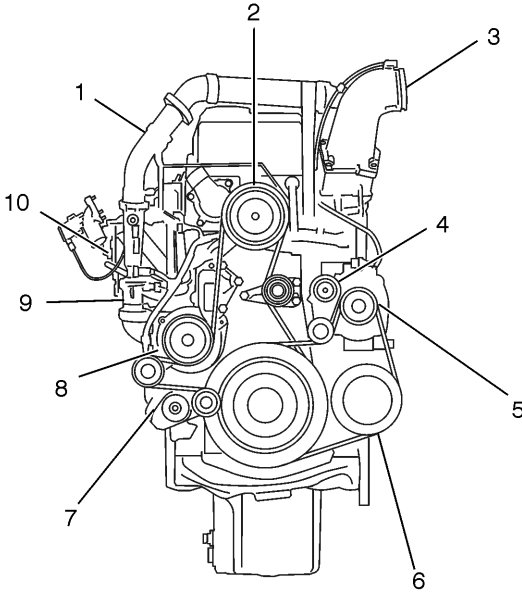

W2032449

Description	Part Number
1. EGR Cooler Outlet Pipe	1. 20900934
2. Fan Drive	2. Check per VIN number
3. EGR Mixer	3. 21033737
4. Belt Tensioner (Alternator/Refrigerant Compressor Belt)	4. 20762060
5. Alternator (Pad Mount)	5. Check per VIN number
6. Refrigerant Compressor (Pad Mount)	6. Check per VIN number
7. Belt Tensioner (Fan Drive/Water Pump Belt)	7. 20487079
8. Coolant Pump	8. 85116652
9. Venturi	9. 21012484
10. Differential Pressure Sensors	10. 20930137

Note: All part numbers are for reference only, you should always refer to truck BOM's before ordering parts.

Engine Sensors

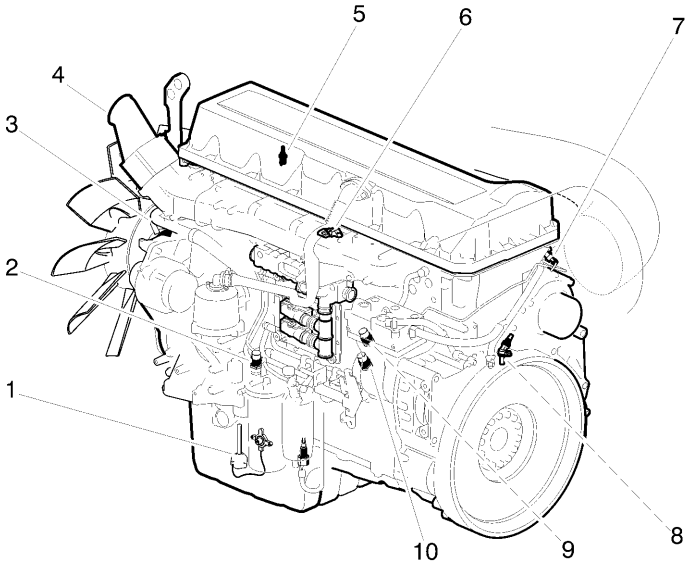

W2032450

Description	Part Number
1. Oil Level/Temperature	1. 21042447
2. Fuel Pressure	2. 20796740
3. Fan Speed (in fan hub)	3. Check per VIN number
4. Boost pressure Sensor	4. 20524936
5. Coolant Temperature (at front edge cylinder of head)	5. 20513340
6. Charge Air Pressure/Temperature	6. 20524936
7. Camshaft Position	7. 20513343
8. Flywheel Position/Speed	8.20513343
9. Oil Pressure	9. 20898038
10. Crankshaft Pressure	10. 20796744

Note: All part numbers are for reference only, you should always refer to truck BOM's before ordering parts.

126 ENGINE COMPONENT AND LOCATION

ENGINE DISASSEMBLED VIEW AND PART NUMBERS

Upper Engine Components

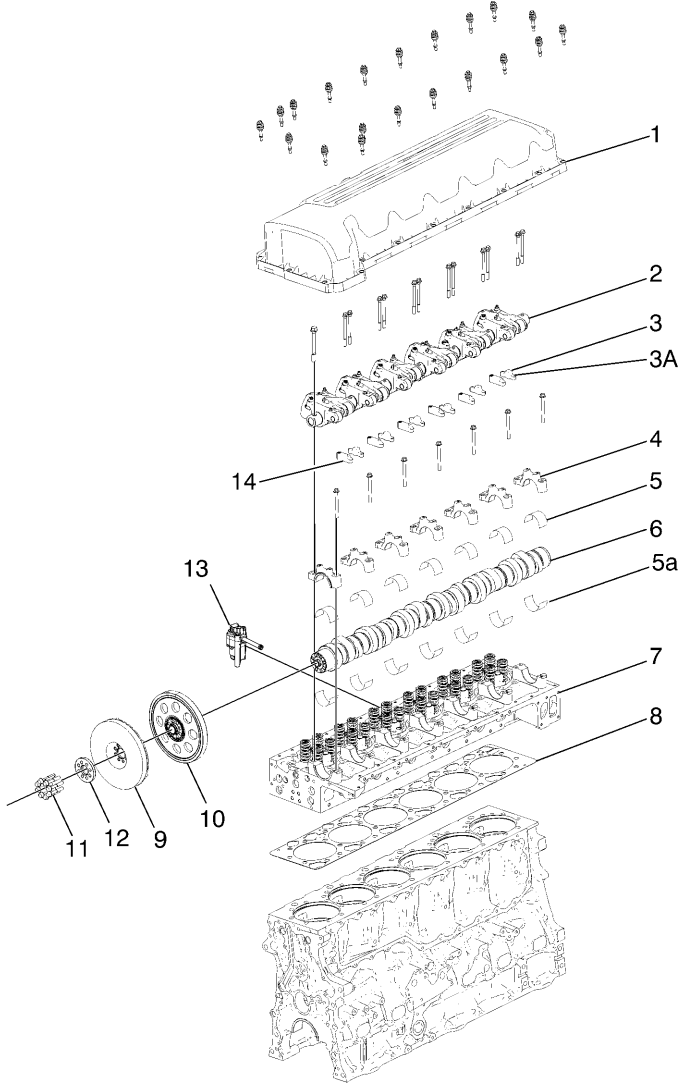

ENGINE COMPONENT AND LOCATION 127

Description	Part Number
1. Valve Cover / Gasket	1. 20538793
2. Rocker Shaft Assembly	2. Check per VIN number
3. Valve Caliper Exhaust	3. Check per VIN number
3A.VEB Shim Kit	3A. 85111158
4. Camshaft Bearing Cap Kit	4. 20825837
5. Camshaft Bearing Front	5. 20999623
5A. Camshaft Bearing Rear	5A. 20999613
6. Camshaft	6. Check per VIN number
7. Cylinder Head	7. 21042138
8. Cylinder Head Gasket Install Kit	8. 21409435
9. Camshaft Vibration Dapner	9. 20888623
10. Camshaft Gear	10. 20891469
11. Camshaft Vibration Damper Bolts	11. 8192804
12. Spacer	12. 20878608
13. Volvo Engine Brake	13. Check per VIN number
14. Valve Caliper Intake	14. Check per VIN number

Note: All part numbers are for reference only, you should always refer to truck BOM's before ordering parts.

128 ENGINE COMPONENT AND LOCATION

Rear Engine Components

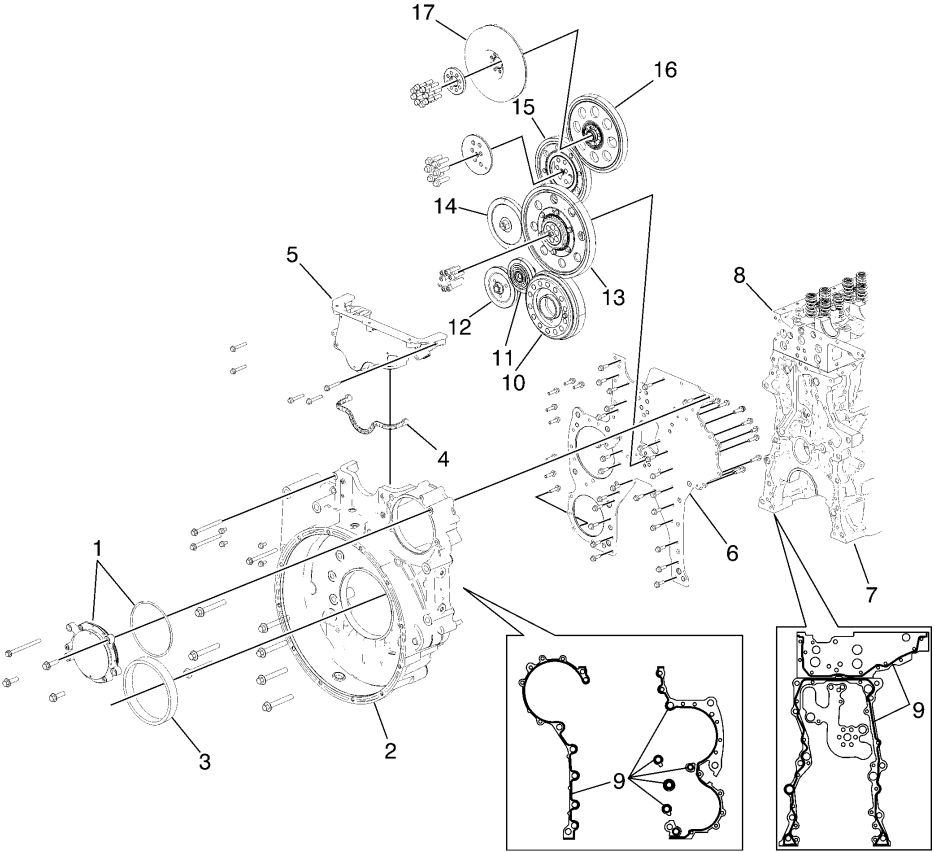

W2032470

ENGINE COMPONENT AND LOCATION 129

Description	Part Number
1. Power Take-Off Cover and Gasket	1. 976068
2. Flywheel Housing	2. Check per VIN number
3. Crankshaft Seal	3. 1543896
4. Timing Gear Cover Sealing Strip	4. 20817742
5. Timing Gear Cover Seals	5. 20572441
6. Timing Gear Plate	6. 21062364
7. Engine Block	7. NSS
8. Cylinder Head Kit	8. 21042138
9. Silicone Sealant	9. 1661231
10. Crankshaft Gear	10. 20743004
11. Auxiliary Idler gear	11. 21049784
12. Power Steering and Fuel Pump Gear	12. Check per VIN number
13. Double Idler	13. 21057068
14. Air Compressor Drive Gear	14. 8131848
15. Adjustable Idler	15. 20850724
16. Camshaft Gear	16. 20891469
17. Harmonic Balancer	17. 20888623

Note: All part numbers are for reference only, you should always refer to truck BOM's before ordering parts.

130 ENGINE COMPONENT AND LOCATION

Oil Pan and Stiffing Frame

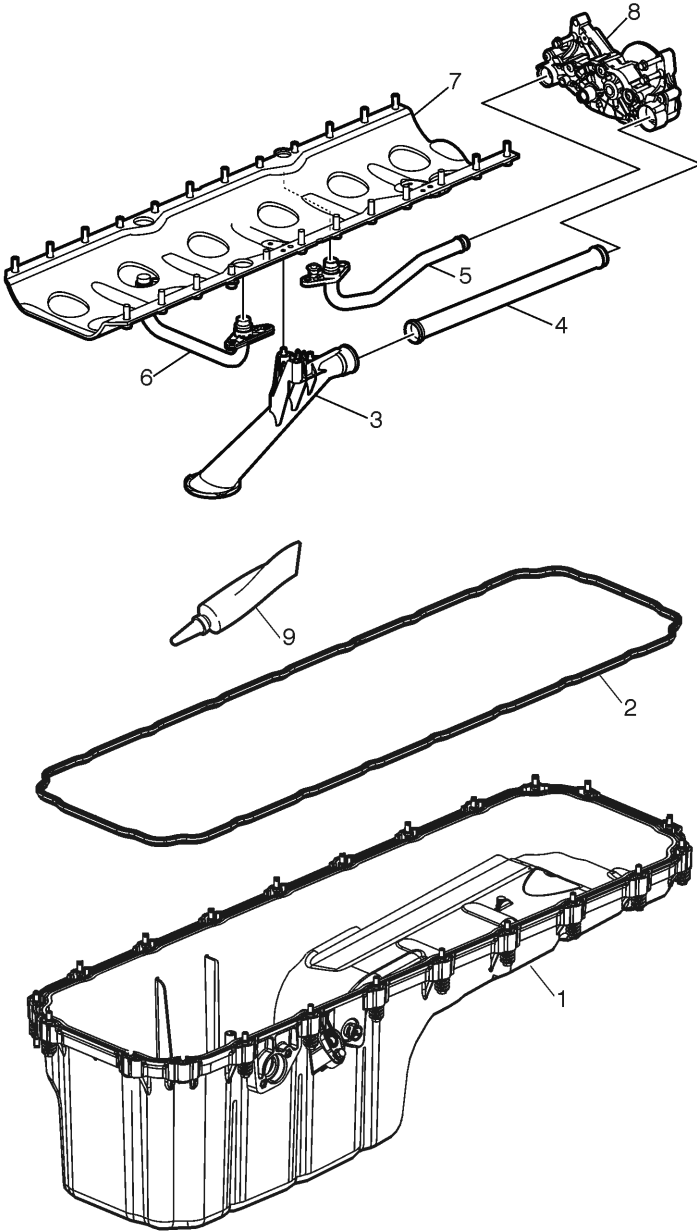

ENGINE COMPONENT AND LOCATION 131

Description	Part Number
1. Oil Pan	1. Check per VIN number
2. Sealing Strip	2. 20515881
3. Oil Strainer	3. 20824910
4. Suction Pipe	4. 20521886
5. Pressure Pipe	5. 20501240
6. Pressure Pipe	6. 20498189
7. Cover	7. 20499612
8. Oil Pump	8. 20824906
9. Sealant	9. 3092340

Note: All part numbers are for reference only, you should always refer to truck BOM's before ordering parts.

132 ENGINE COMPONENT AND LOCATION

Lower Engine Components

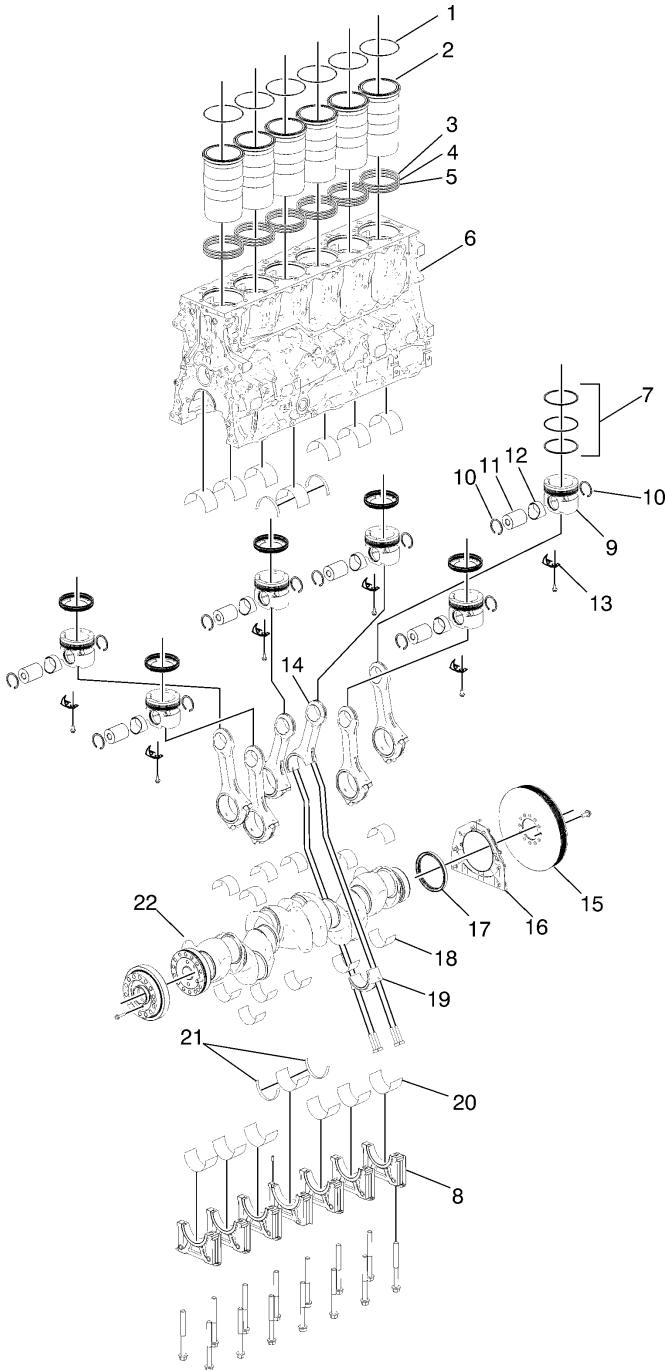

ENGINE COMPONENT AND LOCATION 133

Description	Part Number
1. Upper Cylinder Liner Seal – EPDM (Black)	1. 270950
2. Cylinder Liner	2. 20928630
3. Middle Cylinder Liner Seal – EPDM (Black)	3. 270950
4. Lower Cylinder Liner Seal – Viton (Purple)	4. 270950
5. Lower Cylinder Liner Seal	5. 270950
6. Engine Block	6. 20993042
7. Piston Ring	7. 20747511
8. Main Bearing Cap	8. 20993042
9. Piston	9. 20928630
10. Wrist Pin Clip	10. 2914531
11. Wrist Pin	11. 20928630
12. Wrist Pin Bushing	12. NSS
13. Piston Oil Nozzle	13. 3155151
14. Connecting Rod	16. 20876840
15. Crankshaft Damper	18. 20741749 / 9651191
16. Front Cover to Block Seal	19. 20777233
17. Crankshaft Seal	20. 85108423
18. Lower Connecting Rod Bearing	21. 20580558
19. Connecting Rod Cap	22. 20876840
20. Lower Main Bearing	23. 20530916
21. Thrust Washer	24. 3093651
22. Crankshaft	26. 20486222

Note: All part numbers are for reference only, you should always refer to truck BOM's before ordering parts.

134 ENGINE COMPONENT AND LOCATION

Replacement Kits

Engine Replacement Kits

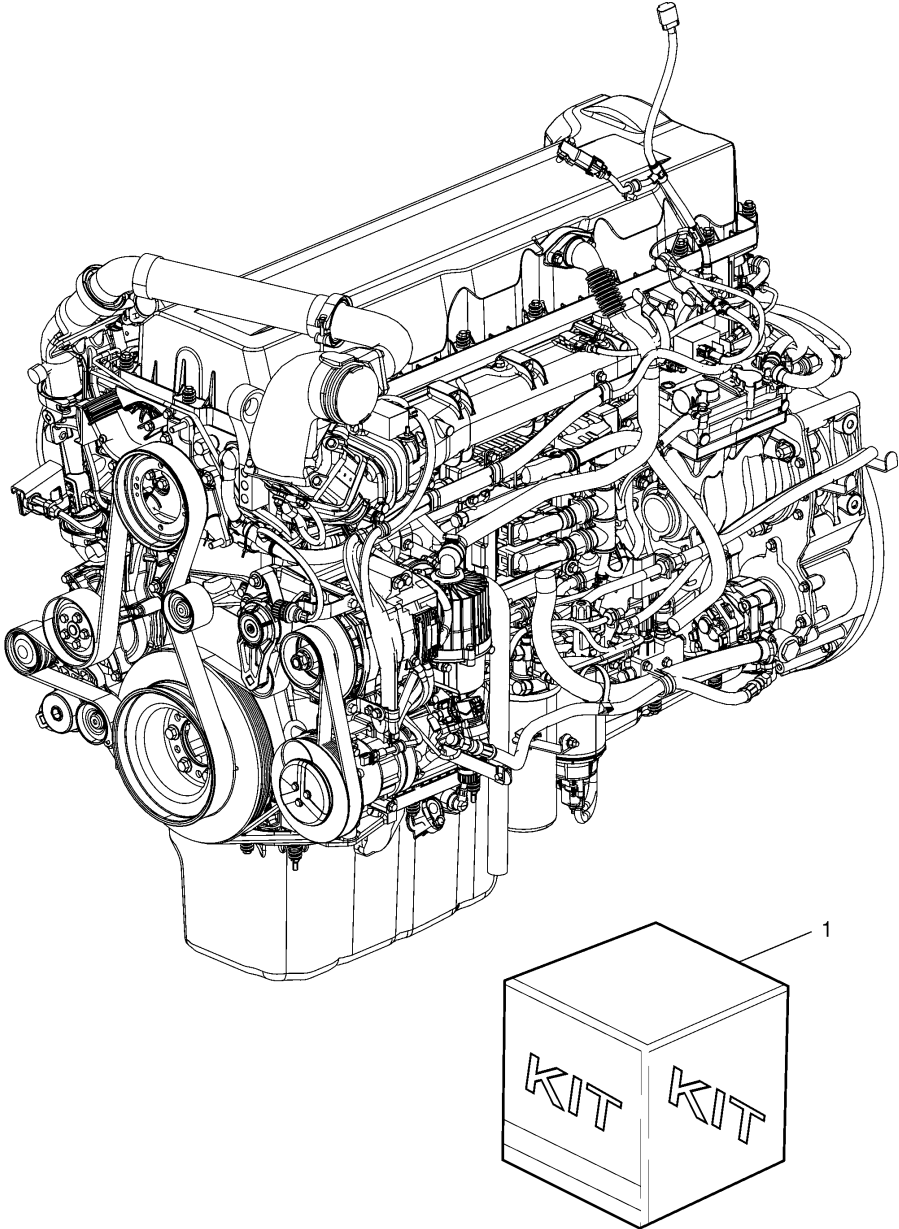

ENGINE COMPONENT AND LOCATION 135

Description	Part Number
Repair Kits, Main and Big-end Bearings	20530916
CCV Pipe Connection Replace Kit	20586428
Fuel Pump Replace Kit	85111130
Coolant Pump Replace Kit	85116652
Cylinder Head Kit	21409435
EGR Cooler Replace Kit	85111060
EGR Valve Replace Kit	85111067
Injector Sleeve Replace Kit	85115712
Oil Cooler Replace Kit	85111858
Coolant Filter Valve Kit	20566236
Engine Overhaul Kit	85115734
2cyl Air Compressor Kit	85116640
Turbocharger Replace Kit	Check per VIN number
Filter Kit	85112873

Note: All part numbers are for reference only, you should always refer to truck BOM's before ordering parts.

Maintenance

Oil Level Check

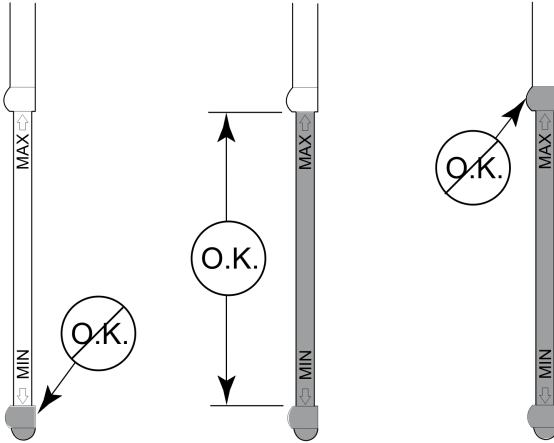

W2033374

When checking oil levels, the vehicle must be parked on level ground and the engine at normal operating temperature. Components must be filled to the correct level. **DO NOT OVERFILL.**

The best time to check oil level is while the engine is **COLD** (prior to starting at the beginning of the work day, or after the vehicle has sat approximately 2 hours). At normal operating temperature (engine oil temperature above 80°C [175°F]), oil level can be checked 15 minutes after shut down.

For accurate oil level readings, the dipstick must be inserted fully into the dipstick tube. The level must be close to the **FULL** line (at least between the **LOW** and **FULL** lines) on the dipstick, but must **NOT** exceed the **FULL** line.

Note: SPECIAL TOOL 9998487 WILL BE NEEDED.

Oil and Filter Change Procedure

This engine is equipped with improved spin-on type oil filters.

DISPOSABLE SPIN-ON OIL FILTER REPLACEMENT

Change oil and replace oil filters using the following procedure:

Note: Install new filters dry.

- 1 Run the engine until normal operating temperature is reached. Then, shut off the engine and drain the oil before the engine cools.
- 2 Thoroughly clean the area around the filters before removing.
- 3 Using filter wrench 9998487 or equivalent, remove the spin-on filters and wipe the filter mounting base clean.
- 4 Apply a film of clean engine oil to the sealing gasket on each new filter. Apply a film of clean engine oil to the sealing gasket on each new filter.
- 5 Install the filters and tighten $3/4$ to 1 turn after the gasket contacts the base.
- 6 Fill the crankcase with the recommended engine oil.
- 7 Start the engine and check for leaks. Run the engine for approximately five minutes, then shut it off and recheck the oil level. Add oil if necessary.

Note: Use of anything other than genuine Volvo filters may cause damage and void the engine warranty. Change filters according to the recommended maintenance schedule.

Crankcase Ventilation System

The crankcase ventilation (CCV) system separator is not repairable. If there is apparently faulty operation, perform these inspections before replacing the separator.

- 1 Inspect the separator inlet hose and connectors at the valve cover and at the separator. Remove any obstruction, oil film, residue and particles.
- 2 Inspect the separator outlet hose and connector. Remove any obstruction, oil film, residue and particles.
- 3 Remove the separator and attempt to turn the turbine manually. If it does not turn easily, replace the separator.
- 4 If the turbine turns easily, inspect and clean the oil jet nozzle.
- 5 Reassemble the separator and the hoses.
- 6 If faulty operation continues, continue fault tracing with Guided Diagnostics.

Fuel Filter Replacement

Filter Description

Two filters ensure that clean, waterless fuel reaches the electronic unit injectors. One is a full-flow filter, the other is a water separating pre-filter with a transparent cup to collect and drain the water. A water-in-fuel sensor informs the driver of excessive accumulation in the cup. The water separating pre-filter is in the "suction side" of the fuel circuit. It is a spin-on type with one end of its casing threaded to receive the cup.

The full-flow main filter is on the "pressure side" of the circuit. It is also an easily replaced spin-on filter. The casing completely encloses the filter element. This filter is rated at 3 – 5 microns.

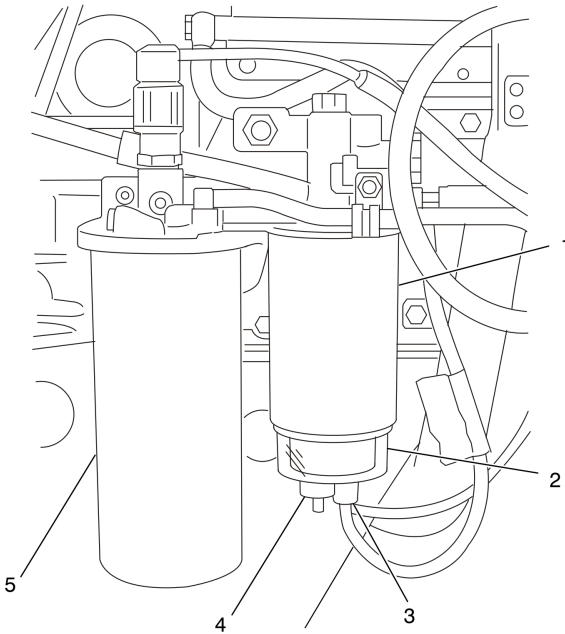

W2033375

- | | |
|---------------------------------|--------------------------|
| 1. Water Separating Pre-Filter | 4. Drain Assembly |
| 2. Water Separator Bowl | 5. Full-Flow Main Filter |
| 3. Water-in-Fuel Sensor Harness | |

Fuel Filter Replacement

Note: Because of ice buildup or fuel waxing which can clog fuel filters, it may be necessary during extremely cold weather to reduce the time or mileage interval between fuel filter changes.

Be careful to prevent foreign matter of any kind from entering the filters during service.

Install new fuel filters dry.

Water Separating Pre-Filter Replacement

To replace the water separating pre-filter:

- 1 Disconnect the electrical cable.
- 2 Make sure the filter casing is thoroughly cleaned. If not already done, wash the area around the filter mounting adapter with a suitable solvent and blow dry with compressed air.
- 3 With a suitable container in place to collect spillage, open the fitting and drain the filter.
- 4 Unscrew and remove the water cup.
- 5 Using a filter wrench, remove the filter from the mounting bracket and discard it safely.
- 6 Apply a thin film of clean engine oil to the sealing gasket of the new filter.
- 7 Screw the new dry filter in place and tighten an additional 3/4 to 1 turn by hand after the gasket contacts the base.
- 8 Screw the water cup into the filter casing.

Note: There is a new-style pre-filter with a stepped-down diameter at the bottom of the filter. The earlier-style filter has straight sides with a larger bottom diameter which requires an adapter to attach the fuel/water separator bowl to the filter. When replacing the previous straight-sided filter with the current stepped-down version, the adapter is not used. However, do not discard the adapter as it can be used should inventory of the earlier-style filter still be available.

- 9 If necessary, replace the full-flow main filter. See the following instructions.
- 10 Connect the electrical cable.
- 11 Start the engine and run at idle for five minutes to fill the filter with fuel.
- 12 Check for leaks.

Full-Flow Main Filter Replacement

To replace the full-flow main filter:

- 1 Make sure the filter casing is thoroughly cleaned. If not already done, wash the area around the filter mounting adapter with a suitable solvent and blow dry with compressed air.
- 2 Put a suitable container in place to collect spillage.
- 3 Using a filter wrench, remove the filter casing from the mounting bracket and discard it.
- 4 Apply a thin film of clean engine oil to the sealing gasket of the new filter.
- 5 Screw the new dry filter in place and tighten an additional 3/4 to 1 turn by hand after the gasket contacts the base.
- 6 If necessary, replace the water separating pre-filter. See the preceding instructions.
- 7 Start the engine and run at idle for five minutes to fill the filter with fuel.
- 8 Check for leaks.



CAUTION

Severe engine damage may be caused by attempting to prime the fuel system using an auxiliary pump or by applying air pressure in the fuel tank. These techniques may destroy seals that prevent fuel from leaking into the crankcase.

Cooling System Maintenance

Note: SPECIAL TOOL J48061 WILL BE NEEDED.

Coolant Drain Outlets

Extra outlets provide convenient drain sites for use during maintenance and other procedures involving coolant.

Coolant Filter

The coolant filter attaches to the back of the coolant pump housing. It resembles a spin-on oil filter. The filter element and casing are replaced as a unit.

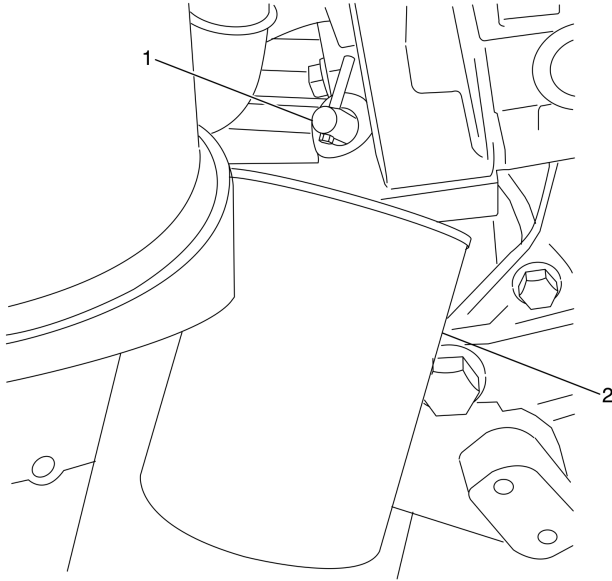

W2033376

1. Shut-Off Valve	2. Coolant Filter
-------------------	-------------------

142 BASIC SERVICE

Note: VCS coolant is used to protect the cooling system.

Remove and Replace

- 1 Close the shut-off valve on the coolant pump housing.
Note: In the closed position, the pin on the shut-off valve should be horizontal.
- 2 Place a suitable container below the filter to collect spilled coolant.
- 3 Using filter wrench J 48061 or equivalent, unscrew the filter and discard it safely.
- 4 Apply a light film of coolant on the face of the new filter gasket.
- 5 Screw the new filter on the threaded nipple extending from the mounting flange.
- 6 Using the filter wrench, tighten the filter one full turn after the gasket contacts the base.
- 7 Open the shut-off valve on the coolant pump housing.
- 8 Check for any coolant leaks.

Exhaust Aftertreatment System Maintenance

Diesel Particulate Filter

The diesel particulate filter should be removed from the system and replaced at the recommended service interval. If the filter is not replaced, it will become clogged and increase exhaust back pressure. As back pressure increases, engine power and economy decline as does the ability of the system to remove undesirable emissions.

Compact Unit



WARNING

The components reach high temperatures during use. Ensure that the unit has cooled to the touch before handling. Failure to heed this warning may result in severe personal injury.

Removal

1. When the fairing (if present), braces and steps have been removed to permit access, remove the lines and sensors connecting the inlet module to the other modules.
2. Disconnect wiring and sensor connectors from the DPF and outlet modules. Cut tie straps securing the lower portion of the DPF harness to the muffler body. Also, remove the pressure differential sensor tube that connects to the outlet module.

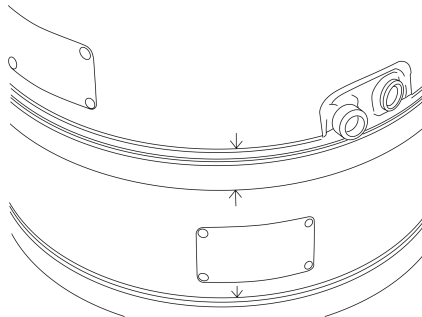

W2033378

3. Using a marker, make alignment marks on each of the module sections, above and below each V-band clamp.

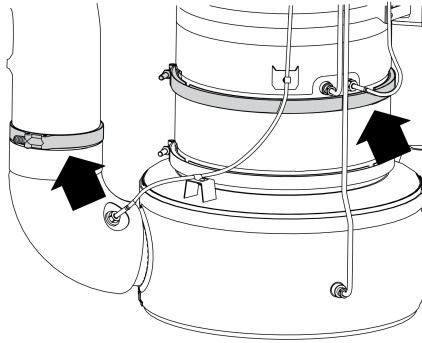

W2033379

4. Remove the lower exhaust V-band clamp that connects the DPF outlet module to the exhaust pipe. Also, remove the V-band clamp that connects the catalyst module to the filter.

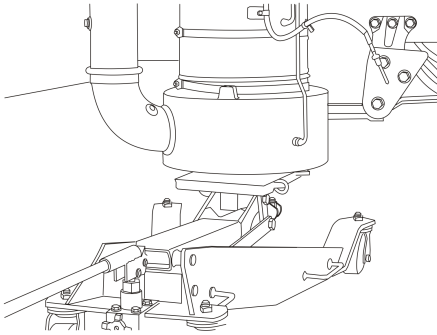

W2033380

5. Position a flat surface jack with a very stable support (such as a transmission jack) under the base of the DPF

6. Remove the fasteners that secure the DPF lower supporting bracket to the chassis frame bracket. This releases the weight of the DPF onto the transmission jack.

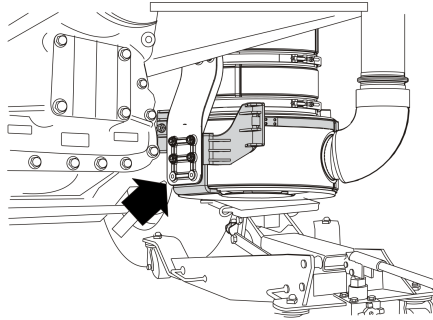

W2033381

7. Lower the DPF unit and roll the transmission jack from the right side of the chassis to remove the lower portion of the DPF.
8. Loosen the nut securing the large V-band clamp between the exhaust outlet module and the filter module
9. Separate the DPF from the outlet module.
10. Remove and discard the gaskets.
11. Inspect and replace the V-band clamps showing galled threads, cracks or heat damage. Clean all exposed gasket surfaces.

Installation

1. Install a new gasket between the outlet and DPF modules.
 2. Using alignment marks made at disassembly, position the DPF over the outlet module and connect using the V-band clamp tightened to specifications.
- Note:** Make sure the high-temperature gasket remains in place and has not become dislodged.
3. Place a new high-temperature gasket on top of the DPF module.
 4. Perform the following steps to align and lift the filter and outlet module assembly into position:
 - Align the outlet module flange to the exhaust pipe.
 - Align the locator tab at the filter module with the slot located in the bottom of the catalyst module.
 - Start all fasteners that connect the lower supporting bracket to the chassis frame bracket.
 5. Install the V-band clamp that joins the DPF and catalyst modules. Tighten the band clamp fastener to specification.

Note: Make sure the high-temperature gasket remains in place and has not become dislodged.

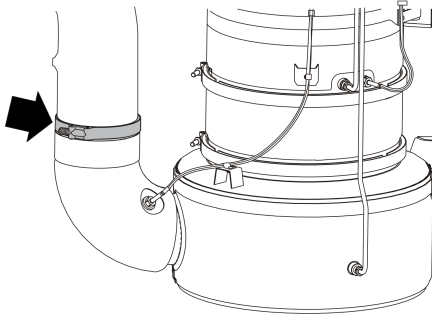

W2033382

6. Install and tighten the V-band clamp that joins the outlet module to the exhaust pipe.

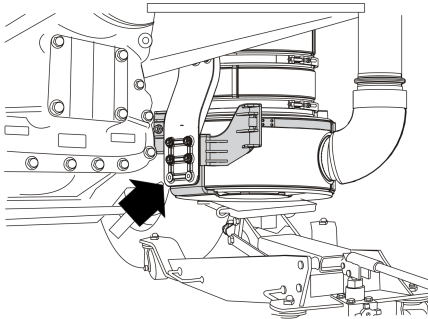

W2033381

7. Secure the DPF bracket to the chassis frame bracket and tighten all fasteners to specification.
8. Remove the transmission jack from under the assembly.
9. Install the pressure differential sensor tube that connects to the outlet module and tighten fitting to specification.

Note: A high-temperature anti-seizing compound should always be applied to the threads of the sensors, plugs and fittings in the exhaust system to avoid component seizure or corrosion.

10. Install the lines and sensors connecting the various modules to each other. Refer to torque specifications for the V-band clamp screws, lines and sensors in the SPECIFICATIONS section of this manual
11. Install the fairing (if equipped), braces and steps that were removed to permit access.
12. Using Premium Tech Tool (PTT), ensure all soot trigger levels are reset back to zero.

Vertical Back-of-Cab Unit



WARNING

The components reach high temperatures during use. Ensure that the unit has cooled to the touch before handling. Failure to heed this warning may result in severe personal injury.

Removal

1. Remove the heat shield, stack, harness clamps, tie straps and V-band clamp at the exhaust elbow.
2. Disconnect all harness connectors.

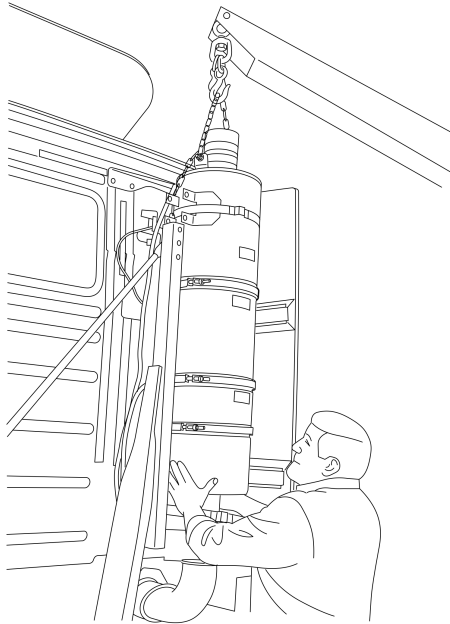

W2033377

3. Using a suitable lifting device, support the assembly. Remove the band clamps and mounting bracket from the stanchion.
4. Remove the assembly from the chassis and place it in the VBOC DPF support stand, 85111327, or equivalent.

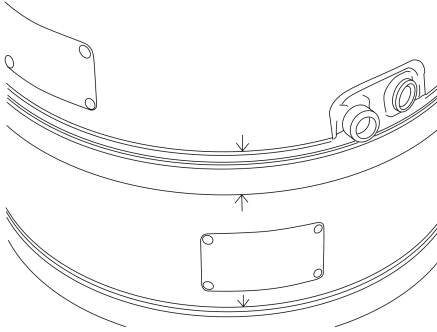

W2033378

5. Using a marker, make alignment marks on each of the module sections, above and below each V-band clamp.
6. Remove the pressure differential tube from the catalytic filter module.
7. Remove the V-band clamp joining the outlet module to the filter module.

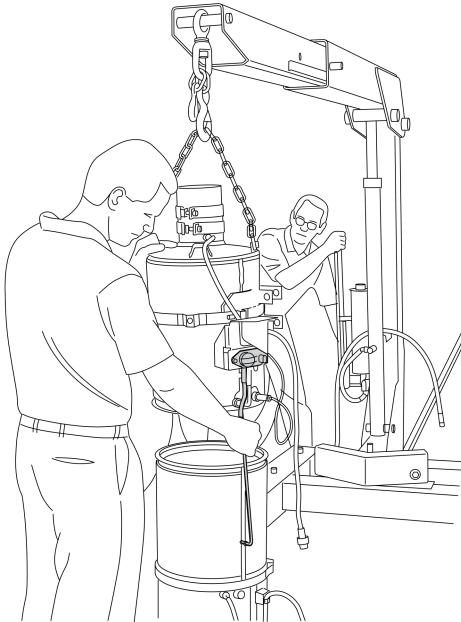

W2033384

8. With an assistant and a suitable lifting device, remove the outlet module from the DPF filter module.
9. Remove the V-band clamp joining the DPF filter module to the catalytic filter module.

Installation

1. Install a new gasket between the catalytic filter module and the DPF filter module.
2. Align the locator tab located on the bottom of the DPF filter module with the slot located in the top of the catalytic filter module. Install the DPF filter module onto the catalytic filter module and secure the modules together using a V-band clamp tightened to specification.
3. Install a new gasket between the outlet module and the DPF filter module.

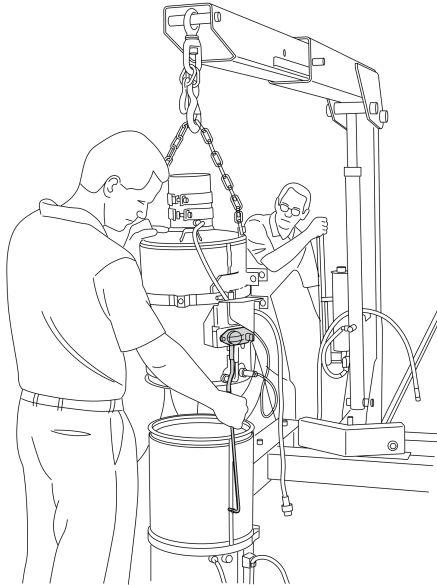

W2033384

4. With assistance, use a suitable lifting device to install the outlet module onto the DPF filter module. Ensure that the differential pressure tube does not become damaged during outlet module installation.

Note: Make sure the high-temperature gasket remains in place and has not become dislodged.

5. Install the V-band clamp to secure the outlet module to the DPF filter module and tighten clamp fasteners to specification. All clamps should now be aligned and tightened.

6. Install the pressure differential tube to the port on the catalytic filter module and tighten the fitting securely.

Note: A high-temperature anti-seizing compound should always be applied to the threads of the sensors, plugs or fittings in the exhaust system to avoid component seizure or corrosion.

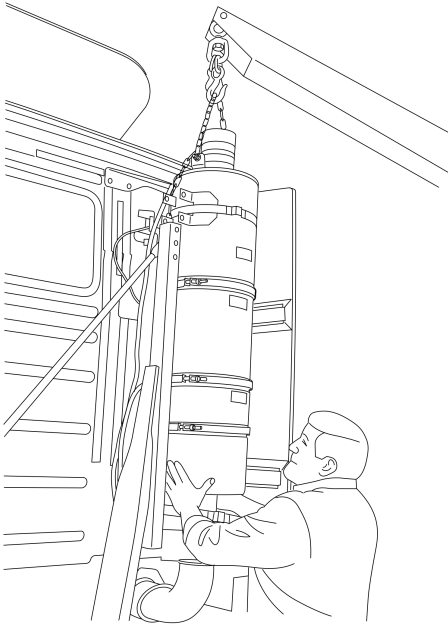

W2033377

7. Lift the DPF muffler using a suitable lifting device and with assistance, position the muffler next to the frame-mounted stanchion, at the back of the cab.

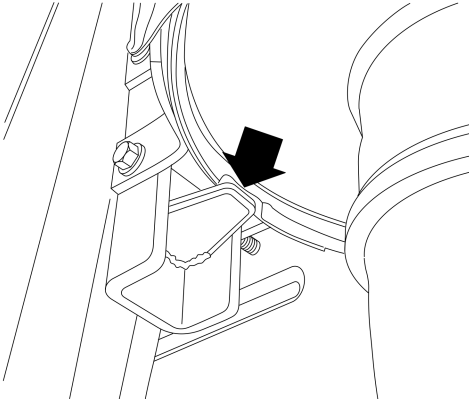

W2033385

8. Align the slot in the muffler bottom with the tab on the stanchion.

9. Perform the following steps to align the DPF muffler into final position on the muffler stanchion:
 - Align the muffler inlet with the exhaust elbow.
 - Align the muffler upper supporting bracket to the stanchion and install the bolts loose.
 - Loosely install the upper supporting band clamp with attached bracket and install bracket bolts into the stanchion.
 - Loosely install the lower supporting band clamp.
10. With all components aligned, install and secure the lower V-band clamp at the inlet side of the muffler.
11. Install the heat shield onto the DPF muffler.
12. Secure all fasteners and clamps that connect the DPF muffler to the stanchion. Tighten all clamps and muffler fasteners according to specification.
13. Disconnect the lifting device and remove the lifting chain from the muffler.
14. Reconnect the harness connectors for all temperature and pressure differential sensors on the DPF muffler.
15. Locate torque specifications for the V-band clamp screws, lines and sensors in the SPECIFICATIONS section of this manual.
16. Using the Premium Tech Tool, (PTT) ensure all soot trigger levels are reset back to zero.

Aftertreatment Fuel Injector (AFI)



WARNING

When replacing the AFI, check the part number of the injector to ensure that an injector with a proper flow rate for the engine is installed. Installing an injector with the incorrect flow rate may cause dangerously high regeneration temperatures and subsequent DPF damage.

Removal

1. Apply the parking brake and place the shift lever in neutral.
2. Disconnect all cables from ground (negative) battery terminals to prevent personal injury from electrical shock.
3. Remove P-clamp screws securing the AFI harness and fuel supply line.
4. Connect coolant extraction tool DBT2V700 to the drain fitting at the bottom of the radiator. Drain the coolant.

Note: An alternative method is to use drain hose 9996049 to drain coolant into a suitable container.

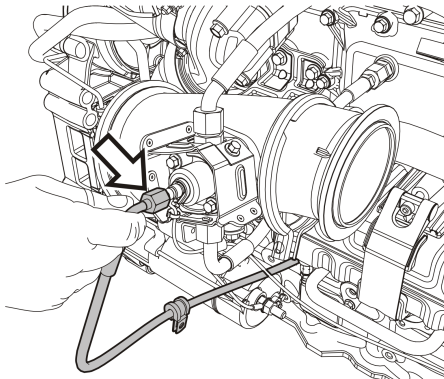

W2005656

5. Disconnect the aftertreatment fuel injector fuel supply line. Collect any residual fuel that might be in the fuel line in a suitable container

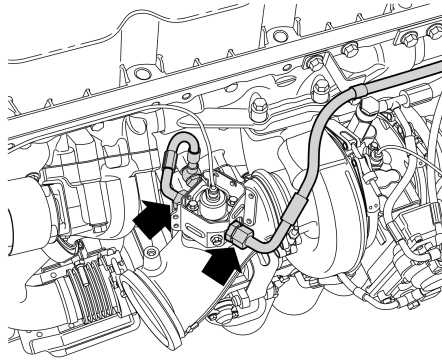

W2033386

6. Disconnect both the inlet and outlet coolant lines from the aftertreatment fuel injector fittings.
7. Disconnect the aftertreatment fuel injector wiring harness connector. Remove all clips and tie straps to allow the harness to hang free.
8. Remove and discard the aftertreatment fuel injector mounting bolts and spacers, and then remove the injector from the diffuser pipe attached to the turbocharger outlet.

Note: Mark the AFI orientation relationship to the diffuser. With the early-style diffuser, the AFI is positioned with the higher side of the AFI heat shield facing the turbocharger. With the new-style diffuser, the AFI is positioned with the higher side of the heat shield facing the EGR valve.

9. Remove and discard the high-temperature gasket and steel plate gasket from the bottom of the injector.

Installation

1. Install a new high-temperature gasket and steel plate gasket onto the bottom of the aftertreatment fuel injector.
2. Apply high-temperature nickel-graphite anti-seize compound to new injector mounting bolt threads and insert the bolts into the spacers. Position the injector onto the diffuser pipe (attached to the turbocharger outlet) and hand start the bolts with spacers.

Note: Install the AFI as marked at disassembly.

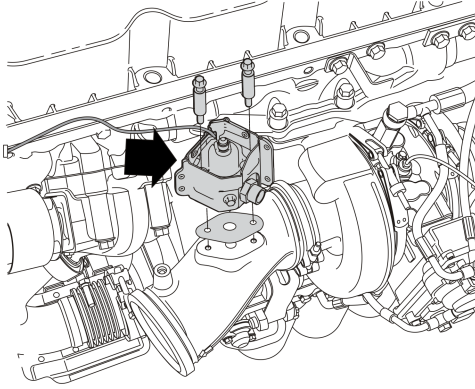

W2033387

3. Secure the injector mounting bolts. Tighten the bolts according to specification.
4. Reconnect the aftertreatment fuel injector wiring harness connector. Secure the injector wiring harness with clips and tie straps.

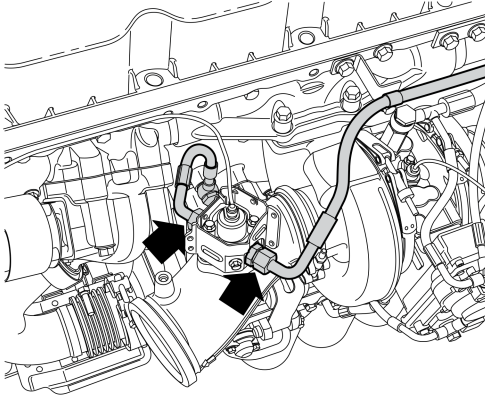

W2033386

5. Reconnect the coolant lines to the aftertreatment injector fittings and tighten to specification.

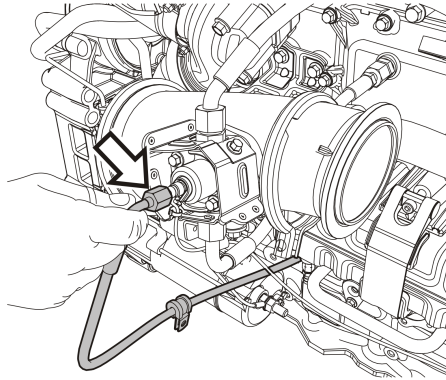

W2005656

7. Install the P-clamp and screws to secure the AFI harness and fuel supply line to the diffuser.
8. Fill the engine cooling system with the recommended coolant using the coolant extractor.
9. Install all previously removed cables to the ground (negative) battery terminals.
10. Perform Aftertreatment Injector Adaptive Factor Reset using VCADS/Premium Tech Tool (PTT).
11. Start the engine, check for leaks and proper operation. After shutdown, replenish fluids as necessary.

Cleaning

1. Apply the parking brake and place the shift lever in neutral.
2. Disconnect all cables from ground (negative) battery terminals to prevent personal injury from electrical shock.
3. Remove P-clamp screws securing the AFI harness and fuel supply line.

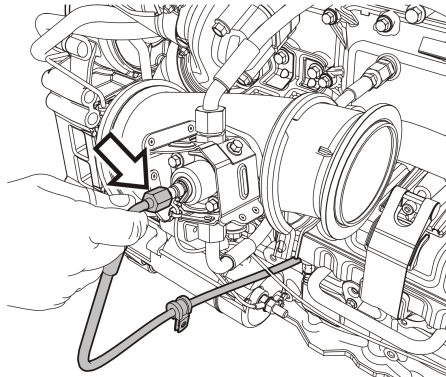

W2005656

4. Disconnect the AFI fuel supply line. Collect any residual fuel that might be in the fuel line in a suitable container.

Note: The coolant lines do not have to be disconnected nor coolant drained for AFI cleaning.

5. Remove and discard the aftertreatment fuel injector mounting bolts and spacers, and then remove the injector from the diffuser pipe attached to the turbocharger outlet.
6. Cover the opening in the diffuser pipe to prevent dirt and cleaning fluid from entering the exhaust system.

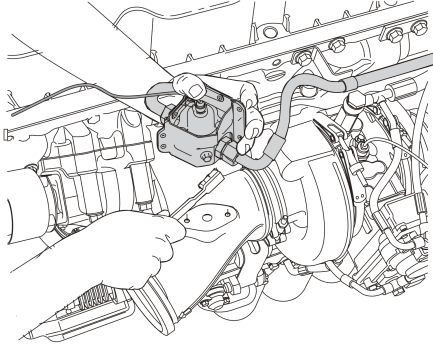

W2033388

7. Remove and discard the high-temperature gasket and steel plate gasket from the bottom of the injector.
8. Carefully turn the AFI body and spray the injector tip with carburetor cleaning solution. Brush the injector tip with a stiff bristled nylon toothbrush. Repeat two or three times.



CAUTION

Do NOT kink the fuel and coolant lines when cleaning the injector. Kinking the lines may result in leakage.



CAUTION

Only carburetor cleaner should be used for cleaning the injector. Other cleaners, such as brake cleaner products, do not work and may contain chlorine that could damage the catalyst if they enter the exhaust system.

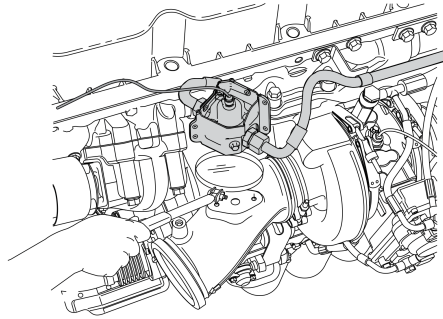

W2033389

9. Inspect the injector tip to make sure it is thoroughly clean and all soot has been removed. Use a mirror if a clear view of the tip is not possible.
10. Install a new high-temperature gasket and steel plate gasket onto the bottom of the aftertreatment fuel injector.
11. Apply high-temperature nickel-graphite anti-seize compound to the new injector mounting bolt threads and insert the bolts into the spacers. Position the injector onto the diffuser pipe (which attaches to the turbocharger outlet) and hand start the bolts with spacers.
12. Secure the injector mounting bolts. Tighten the bolts according to specification.

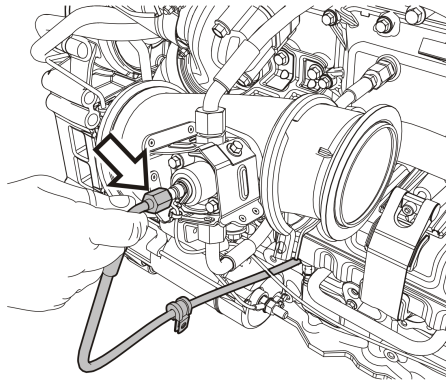

W2005656

13. Connect the aftertreatment fuel injector fuel supply line and tighten to specification.
14. Install P-clamp bolts to secure the AFI harness and fuel line.
15. Connect all previously disconnected cables to the ground (negative) battery terminals.
16. Using VCADS/ Premium Tech Tool, (PTT) reset the AFI adaptive factor, clear codes and test the system for proper operation.

Drive Belt Replacement and Tensioning

General Information

The service life of the multi-groove belts is considerably improved over other systems and allows the use of higher horsepower cooling fans. All D13F engines are equipped with multi-groove belt systems.

In the dual multi-groove drive belt arrangement, the fan drive and coolant pump are driven directly from the crankshaft pulley by a 10- or 12-rib multi-groove belt. The alternator and the air conditioning compressor (if equipped) are driven off the crankshaft pulley by a six-rib multi-groove belt (Figure 71). Two automatic tensioners are used, one for the fan drive and one for the accessory drive.

The lower tensioner for the fan and coolant pump is mounted on the coolant pump housing. This tensioner applies its load counterclockwise. The upper tensioner for the alternator (and refrigerant compressor if so equipped) is mounted on the alternator bracket. The tensioner applies its load in a counterclockwise direction.

Automatically Tensioned System

INSTALLATION

Swing the tensioner to the fully sprung position and without force, using belt tensioner tool, J 44392, place the belt over the pulleys. Do not allow the tensioner to snap against its stops. Do not pry the belt over a pulley.

TENSIONING

No tensioning adjustment is required. Once the tensioner is released against the belt, the belt is tightened to optimum tension automatically at all speeds and loads.

MAINTENANCE

The condition of the belt and tensioner should be checked when performing preventive maintenance inspections. Belt tension levels need not be checked as long as the tensioner is in good condition and there is no evidence of a loose belt.

Valve and Unit Injector Adjustment

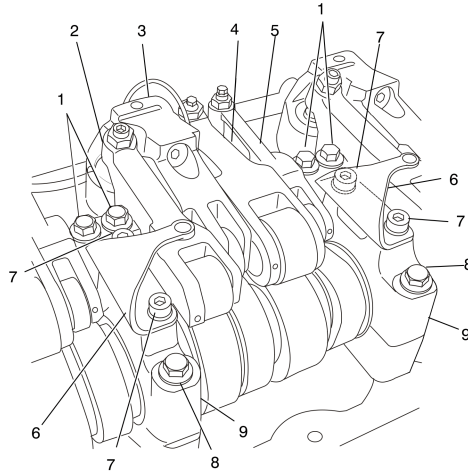

W2033395

- | | |
|--|----------------------------------|
| 1. Rocker Shaft/Bearing Cap Attaching Screws | 5. Inlet Valve Rocker Arm |
| 2. Exhaust Brake Rocker Arm | 6. Plate Spring |
| 3. Exhaust Valve Rocker Arm | 7. Plate Spring Attaching Screws |
| 4. Injector Rocker Arm | 8. Bearing Cap Attaching Screws |
| | 9. Camshaft Bearing Cap |

General Information

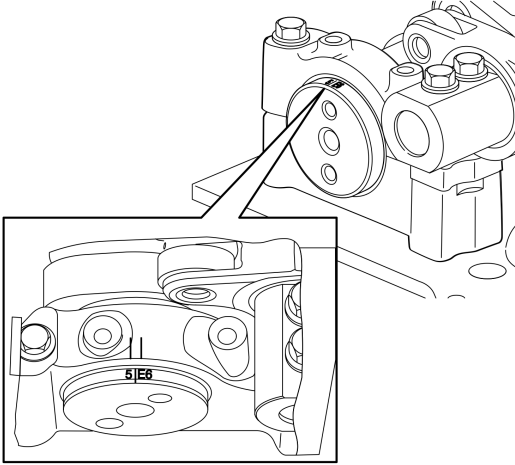

W2033396

Timing marks for basic camshaft timing and adjustment of the valves and unit injectors are located at the front of the camshaft just forward of the No. 1 front bearing journal. Two lines at the top of the front bearing cap mark the alignment point for positioning of the camshaft and making the adjustments.

The top dead center (TDC) mark is used for basic camshaft timing. The TDC mark must be between the two lines on the front camshaft bearing cap when the flywheel is at 0° (top dead center for cylinder No. 1).

The engine must be cold, 60°C (140°F) or less, before making these adjustments.

Camshaft markings for setting of valves and unit injectors:

- **Without Volvo Engine Brake** : Markings 1–6 apply to adjustment of inlet valves, exhaust valves and injectors.
- **With Volvo Engine Brake** : Markings 1–6 apply to adjustment of inlet valves and injectors. Markings E1–E6 apply to adjustment of exhaust valves.

Inlet Valve Adjustment



WARNING

Apply the parking brake before barring the engine over. Remove the EMS power supply fuse to avoid starting the engine unintentionally. Make sure that the transmission is not in gear.

With the engine cold, 60°C (140°F) or less, check and adjust the valves and injector as required for each cylinder before moving to the next. Follow this sequence of cylinders when adjusting clearances: 5, 3, 6, 2, 4 and 1.

1. Using the flywheel turning tool, 88800014, bar the engine over manually to the appropriate camshaft marking for adjustment of the inlet valves and injector for that cylinder.

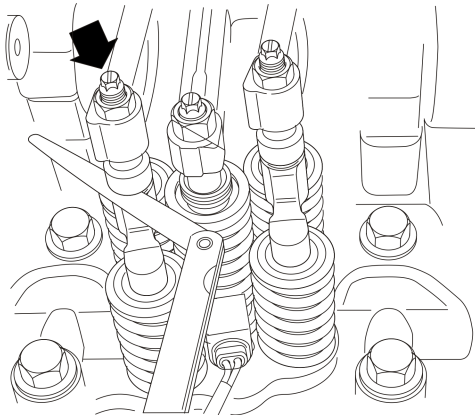

W2033397

2. Using a feeler gauge, check the clearance between the rocker arm adjusting screw and the valve yoke (bridge) of the inlet valves.
3. If the clearance is not within specification, loosen the locknut and adjust the clearance as required.
4. Hold the adjusting screw to prevent it from turning and tighten the locknut to specification.
5. Recheck the clearance after tightening the locknut.
6. Mark the respective rocker arm as each adjustment is completed.

Unit Injector Adjustment

The unit injector adjustment is done with the engine and camshaft in the same position as for the inlet valve adjustment on each cylinder.

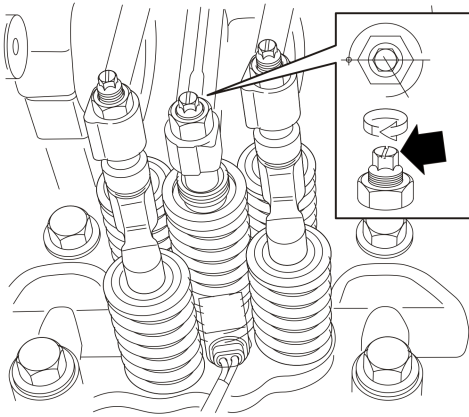

W2033398

1. Loosen the injector rocker arm adjusting screw jam nut and turn the adjusting screw out (counterclockwise) to relieve the preload.
2. Turn the adjusting screw in (clockwise) until it firmly contacts the injector. Do not compress the spring.
3. Turn the adjusting screw in a further 240° (four flats on the hex head).
4. Hold the adjusting screw to prevent it from turning further and, using a torque wrench, tighten the jam nut to specification.
5. Mark the respective rocker arm as each adjustment is completed.

Exhaust Valve Adjustment (WITHOUT Volvo Engine Brake)

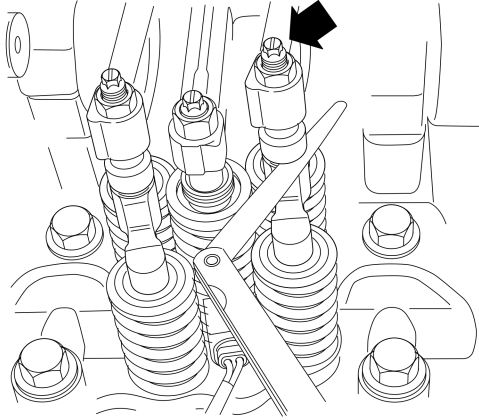

W2033399

1. At the current camshaft setting used for the inlet valves, adjust the exhaust valves following the same procedure described for adjustment of the inlet valves. However, the valve clearance specification is different.
2. Mark the rocker arm when adjustment is complete.
3. Using the flywheel turning tool, bar the engine over manually to the appropriate marking for the next cylinder. Adjust the inlet valves, unit injector and exhaust valves at that cylinder.

Exhaust Valve Adjustment (WITH Volvo Engine Brake)

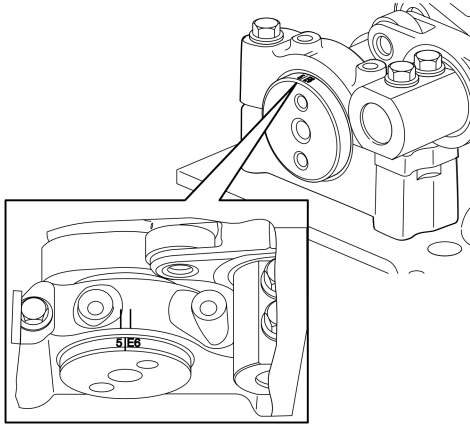

W2033396

Note: The numbers on the camshaft preceded by an E are used to adjust the exhaust valves when the engine is equipped with Volvo Compression Brake (VCB)..

Engines equipped with the VCB engine brake have two rocker arms working in combination to control the exhaust valves. They are the exhaust rocker arm and the brake rocker arm which are adjusted separately as described in the following procedure.

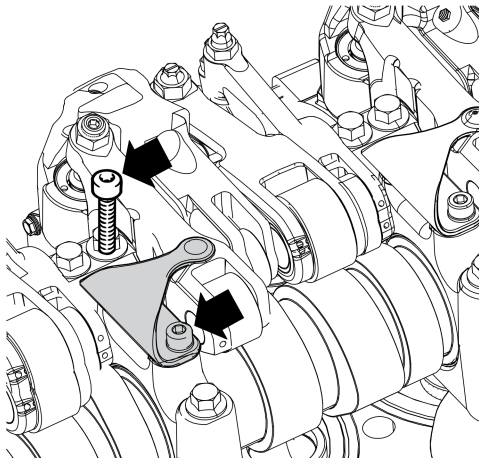

W2033400

1. Loosen the screws holding the plate springs to release the spring tension against the engine brake rocker arms.
2. Using the flywheel turning tool, 88800014, bar the engine over so that the appropriate E number marking is between the lines on the front camshaft bearing cap.

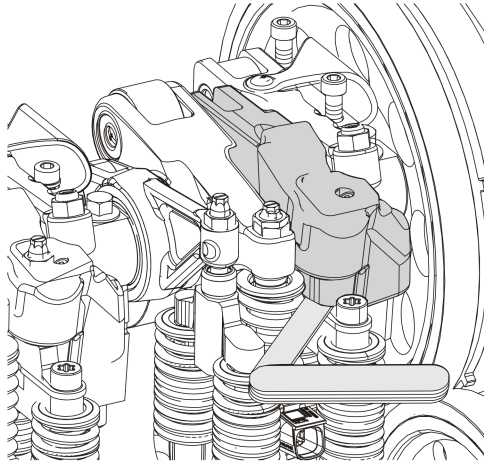

W2033401

3. Measure the clearance between the exhaust rocker arm piston and the shim on top of the valve yoke (bridge).
4. If clearance is not within specification, adjust the clearance as follows, using shims placed on top of the valve yoke (bridge).
Adjusting Exhaust Rocker Arm Clearance
 - a. Remove the shim retaining screw and remove the shim(s).
 - b. Determine the thickness of the shim(s) required to provide the specified clearance.
 - c. Make sure that the valve yoke and shim(s) are clean. Place the shim(s) in position on the valve yoke and install the retaining screw. Tighten the screw to specification.

Note: Do NOT use more than two shims. Shims are available in 0.05 mm (0.002 inch) increments with the thickness marked on the surface. If two shims are required to take up the clearance, the shims should be of nearly equal thickness.
5. Leave the feeler gauge in place between the exhaust rocker arm piston and the valve yoke shim and adjust the brake rocker arm clearance.

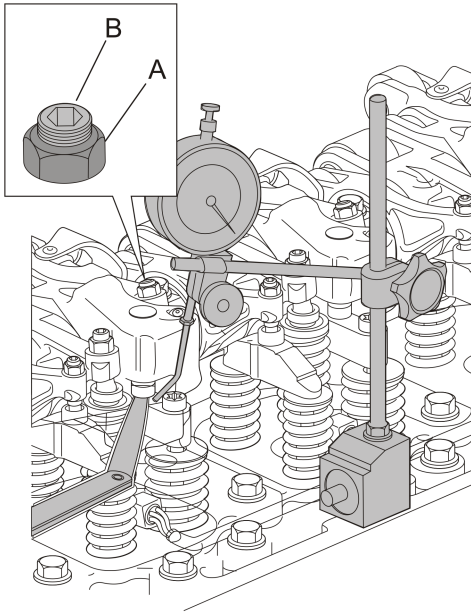

W2033402

A. Locknut

B. Adjusting Screw

- a. Loosen the locknut A on the brake rocker arm adjusting screw.
- b. Using the dial indicator with angled extension and base (9989876, 85111493 and 9999696), place the tip of the dial gauge on the yoke as close as possible to the rocker arm yoke pad. Zero the gauge.
- c. Tighten the rocker arm adjusting screw B until the dial shows that the yoke has been pushed downward 0.60 ± 0.05 mm (0.024 ± 0.002 inch).
- d. Loosen the rocker arm adjusting screw two full turns (720°).
- e. Hold the adjusting screw to prevent it from turning further and, using a torque wrench, tighten the locknut to specification
6. Remove the dial indicator and the feeler gauge.

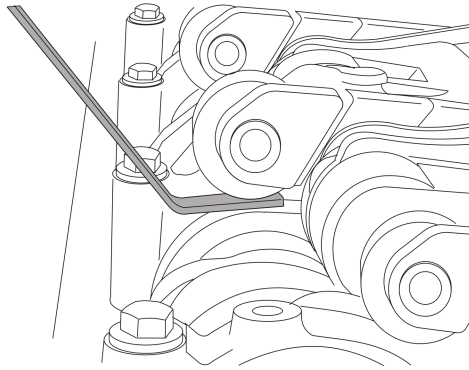

W2033403

7. Using a 3.6 mm (0.142 inch) feeler gauge, 85111377, check the clearance between the brake rocker arm roller and the cam lobe. If the clearance is incorrect, repeat the brake rocker arm clearance adjustment.
8. Mark the respective rocker arm as each valve adjustment is completed.

Continuation of Adjustments

Continue the procedure by barring the engine to the appropriate timing marks and adjusting the valves and unit injectors at each of the remaining cylinders. Follow the steps described above to adjust the inlet and exhaust valves, and unit injector at each cylinder.

For engines equipped with the Volvo compression brake, tighten the plate spring attaching screws to specification after the valve and unit injector adjustments have been completed.

Operational Check

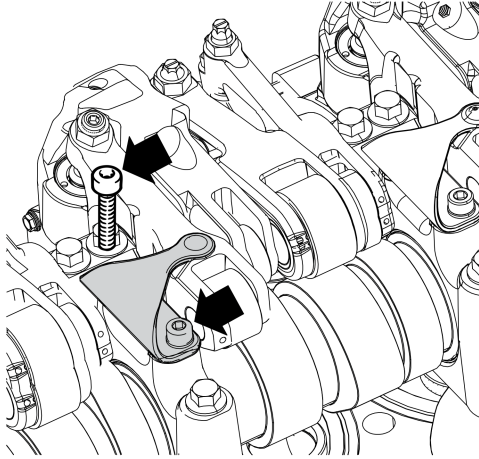

W2033400

After the valve and unit injector adjustments have been completed, check engine operation as follows:

- 1 Using the flywheel turning tool, bar the engine over manually two complete revolutions to ensure that no piston-to-valve contact occurs. If contact does occur, readjust the valves as needed **BEFORE** starting the engine.
- 2 Start the engine and bring it up to normal operating temperature.
- 3 Once normal operating temperature is attained, let the engine idle for an additional five minutes. During this time, the electronic engine management system (EMS) will perform its own cylinder balancing, resulting in smooth engine idling.

Note: Do NOT use any form of power consuming equipment, such as PTO or air conditioning, when cylinder balancing is being carried out.

GLOSSARY OF TERMS

Active Regeneration

Cleaning a diesel particulate filter using an auxiliary heating mechanism to achieve optimum temperature for rapidly inducing chemical changes in the particulate matter trapped in the filter.

Aftertreatment Fuel Injector (AFI)

A device to inject fuel into the exhaust stream between the turbocharger and the diesel particulate filter where it is ignited. This creates the high temperature needed to enable the system to reduce noxious exhaust emissions to the minimum and to regenerate the particulate filter.

Ash

The noncombustible portion of diesel particulate matter. Diesel fuel produces little ash, but crankcase lubricant and fuel-borne catalysts produce considerable ash.

Atmospheric Pressure Sensor

A sensor incorporated into the EECU that detects atmospheric (barometric) pressure and relays this value to the EECU. This pressure is affected by altitude.

Carbon Monoxide (CO)

An odorless, colorless gas resulting from incomplete combustion of hydrocarbons; found in diesel truck exhaust; poisonous to humans and animals.

Catalyst

A substance that promotes or provokes chemical change at a different rate or different temperature than otherwise possible.

Combustion Air Temperature and Humidity Sensor

Mounted in the air intake between the air cleaner and the turbo compressor housing, detects outside air temperature and humidity and relays these values to the EECU.

Compressor Discharge Temperature Sensor

Mounted between the turbocharger compressor housing and CAC, detects compressor discharge air temperature and relays this value to the EECU.

Cooled Exhaust Gas Recirculation (CEGR)

A system whereby a pre-determined amount of exhaust gas is diverted through a heat exchanger where it is cooled and sent to the inlet manifold for reintroduction into the combustion chambers. Adding the cooled exhaust gases to the combustible fuel and air mixture lowers the overall combustion temperatures for reduced formation of nitrogen oxides (NOx).

Cordierite

A ceramic material constructed to be used as a substrate in diesel oxidation catalysts. With additional processing, it may also be used as a diesel particulate filter.

Diesel Particulate Matter

The complex mixture of extremely fine particles and liquid droplets that are discharged by an operating diesel engine. The chemical compositions can be broken down to safer substances.

Differential Pressure Sensors

These are devices designed to read air (gas) pressure at two points in the path of the flow and report the values for use in algorithms in the EECU.

Discharge Recirculation Valve (DRV)

A device used to return some of the turbocharger output air back to the turbocharger to raise the exhaust temperature when needed for active regeneration of the diesel particulate filter.

Electronic Unit Injector (EUI)

Controlled electronically by the EECU, there is one electronic unit injector for each cylinder of an engine. A unit injector incorporates the pump, the injector nozzle and two solenoids in a single body. Actuated by the camshaft via rocker arms with roller followers, electronic unit injectors offer precise fuel metering using a process called "rate shaping."

Engine Electronic Control Unit (EECU)

A microprocessor-based controller usually mounted on the engine block. On the engine, a cooling plate mounts on the surface of the module. A tube on the plate conducts fuel drawn from the tank on its way to the pump before being pressurized. The fuel acts as the coolant. The EECU controls fuel timing and delivery, exhaust gas recirculation, fan operation, engine protection functions and engine brake operation.

Exhaust Aftertreatment System (EATS)

Equipment installed to remove the maximum amount of noxious emissions from the exhaust gases after they leave the combustion chamber before they reach the atmosphere. This includes exhaust gas recirculation (EGR), the variable geometry turbocharger (VGT), the discharge recirculation valve (DRV), the aftertreatment fuel injector (AFI) and the diesel particulate filter (DPF).

Exhaust Gas Recirculation (EGR)

A system whereby a pre-determined amount of exhaust gas is returned to the combustion chambers. Adding a small percentage of exhaust gas to the fuel/air mixture lowers the combustion temperature reducing the formation of nitrogen oxides (NO_x).

Hydrocarbons (HC)

Chemical compounds composed only of carbon and hydrogen. Gasoline, diesel fuel and motor oil are all examples of a very large group of hydrocarbons. The largest source of hydrocarbons is petroleum.

Idler Gear

A gear running between a driving and a driven gear to make the driven gear rotate in the same direction as the driving gear.

Idler Tensioner

A belt tensioning device designed to maintain optimum tension under varying engine speeds and load.

Oxides of Nitrogen (NOx)

High temperatures and pressures of combustion produce oxides of nitrogen (NOx). When combustion temperature exceeds 1372°C (2,500°F), oxygen and nitrogen combine in large quantities to form NOx. By themselves, NOx emissions are no great hazard; however, when mixed with the right amount of HC in the air, NOx will combine in the presence of sunlight to form smog.

Passive Regeneration

Cleaning a particulate filter by spontaneous burning of soot that collects on it. The exhaust temperature remains continuously high enough to incinerate the soot.

Poly-V Belt

A multi-ribbed belt design incorporated into the accessory drive belt and pulley arrangement at the front of the engine.

Regeneration

Cleaning a diesel particulate filter so as to renew its capacity to function efficiently.

Roller Follower

A type of rocker arm with an axle-mounted roller that rides on (or follows) a camshaft lobe. The rolling motion of this design provides increased load capacity with less friction than the flat-faced rocker arm design. Roller followers provide the rocker arm lifting action for the electronic unit injector, intake and exhaust valves and exhaust brake.

Soot

Carbonaceous particulate matter, black in color, found in diesel exhaust. Soot particles are extremely fine. Captured by the diesel particulate filter, their chemical characteristics are changed by the heat to which they are exposed, turning the soot into ash.

Variable Geometry Turbocharger (VGT)

Turbo turbine housing has moving components to control flow of exhaust gas and build back pressure in the exhaust system for EGR flow. The VGT also performs as an engine brake.

VGT Wheel Speed

A sensor mounted in the turbo bearing housing that detects turbine and compressor wheel speed and relays this data to the EECU.

Vehicle Electronic Control Unit (VECU)

A microprocessor-based controller, sometimes referred to as a module, mounted in the cab, inside the passenger-side dash panel. The VECU controls engine speed, cruise control, accessory relay controls, idle shutdown and trip recorder functions.